

# PRODUCT SPECIFICATION

<b>Part Number</b>	USB3190	<b>Rev</b>	A	<b>Date</b>	03/08/20		
<b>Product Description</b>	Micro USB Receptacle, Type B, Surface Mount , Vertical, Low Profile			<b>Page</b>	1		
<b>Doc Number</b>	USB3190	<b>Prepared</b>	<b>CC</b>	<b>Checked</b>	<b>VJ</b>	<b>Approved</b>	<b>PH</b>

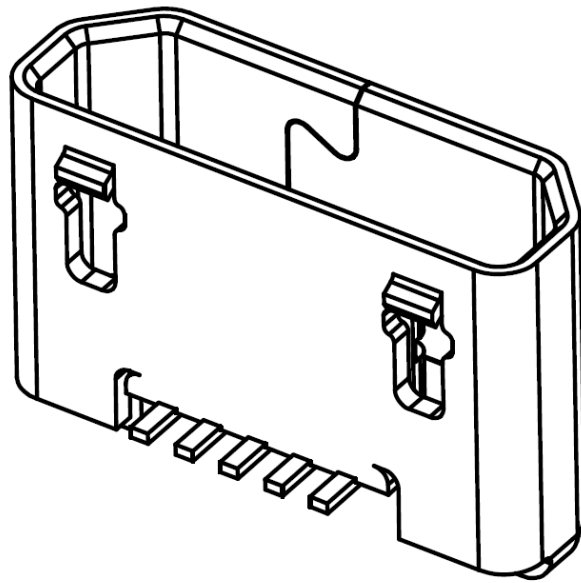

# PRODUCT SPECIFICATION

<b>Part Number</b>	USB3190	<b>Rev</b>	A	<b>Date</b>	03/08/20		
<b>Product Description</b>	Micro USB Receptacle, Type B, Surface Mount , Vertical, Low Profile			<b>Page</b>	2		
<b>Doc Number</b>	USB3190	<b>Prepared</b>	<b>CC</b>	<b>Checked</b>	<b>VJ</b>	<b>Approved</b>	<b>PH</b>

## 1.0 SCOPE.

This specification covers performance, tests and quality requirements for the Micro USB Receptacle USB3180 (Type B, SMT, Vertical)

## 2.0 PRODUCT NAME AND PART NUMBER.

Micro USB Receptacle, Type B, Surface Mount, Vertical, Low Profile: USB3190.

## 3.0 PRODUCT SHAPE, DIMENSIONS AND MATERIAL.

Please refer to drawings.

## 4.0 RATINGS.

4.1 Current rating: Signal (Pins 2, 3, 4) 0.5A

Power (Pins1, 5) 1.8A

4.2 Voltage Rating ..... 30V AC

4.3 Operating Temperature Range .....-30°C to +85°C

## 5.0 TEST AND MEASUREMENT CONDITIONS.

Product is designed to meet electrical, mechanical and environmental performance requirements specified in Paragraph 6.0. All tests are performed in ambient conditions unless otherwise specified.

## 6.0 PERFORMANCE.

Item	Test Condition	Requirement
Examination of Product	Visual, dimensional and functional inspection as per quality plan.	Product shall meet requirements of product drawing and specification.

# PRODUCT SPECIFICATION

<b>Part Number</b>	USB3190	<b>Rev</b>	A	<b>Date</b>	03/08/20		
<b>Product Description</b>	Micro USB Receptacle, Type B, Surface Mount , Vertical, Low Profile			<b>Page</b>	3		
<b>Doc Number</b>	USB3190	<b>Prepared</b>	<b>CC</b>	<b>Checked</b>	<b>VJ</b>	<b>Approved</b>	<b>PH</b>

## 6.1 Electrical Performance.

Item	Test Condition	Requirement
Contact Resistance	When measured at 20mV maximum open circuit at 100mA. Mated test contacts must be in a connector housing In accordance with EIA-364-23.	30 mΩ Max.
Insulation Resistance	Mate/Un-mate connectors, apply 500V DC for 1 minute at sea level between adjacent terminal or ground. In accordance with EIA-364-21.	1000 MΩ Min.
Dielectric Withstanding Voltage	Mate/Un-mate connectors, apply 100V AC for 1 minute at sea level. In accordance with EIA-364-20.	No Breakdown.

## 6.2 Mechanical Performance.

Item	Test Condition	Requirement
Mating/Un-mating Force	Mate/Un-mated at a rate of 12.5mm/min. In accordance with EIA-364-13.	Mating force: 35N Max. Un-Mating force: 8N Min. to 25N Max.
Durability	10,000 cycles at a cycle rate of 500 cycles per hour if done automatically and 200 if manual cycles. In accordance with EIA-364-09.	Appearance: No Damage. Mating force: 35N Max. Un-Mating force: 8N Min. to 25N Max Contact Resistance: 40mΩ Max.
Vibration	Mate connectors and subject to 5.35 Gs RMS. For a period of 15 minutes in each of the 3 mutually perpendicular axes. In accordance with EIA-364-28 Test condition V test letter A.	Appearance: No Damage. Contact Resistance: 40 mΩ Max. Discontinuity: 1.0 μ second Max.
Mechanical Shock	Mate connectors and subject to the following shock conditions, 3 shocks shall be applied along 3 mutually perpendicular axis (Total of 18 shocks). Test Pulse at Half Sine Peak Value: 294 m/s <sup>2</sup> (30G) Duration: 11ms. In accordance with EIA-364-27. Test condition H.	Appearance: No Damage. Contact Resistance: 40 mΩ Max. Discontinuity: 1.0 μ second Max.

# PRODUCT SPECIFICATION

<b>Part Number</b>	USB3190	<b>Rev</b>	A	<b>Date</b>	03/08/20		
<b>Product Description</b>	Micro USB Receptacle, Type B, Surface Mount , Vertical, Low Profile			<b>Page</b>	4		
<b>Doc Number</b>	USB3190	<b>Prepared</b>	<b>CC</b>	<b>Checked</b>	<b>VJ</b>	<b>Approved</b>	<b>PH</b>

## 6.3 Environmental Performance and Others.

Item	Test Condition	Requirement
Humidity Test	Subject mated connectors to Duration: 168 hours temperature between +25°C to +65°C with 90 to 95% RH. In accordance with EIA-364-31. Test condition A method III	Appearance: No Damage. Contact Resistance: 40 mΩ Max. Insulation Resistance: 100 MΩ Min. Dielectric Strength: No Breakdown.
Salt Spray	Subject mated/unmated connectors to 5% salt-solution concentration, 35°C for 24 hours. In accordance with EIA-364-26, Test Condition B.	Contact Resistance: 40mΩ Max. No visible rust on contact area
Temperature Life	Subject mated connectors to temperature life at +85°C for 500hours. In accordance with EIA-364-17. Test condition 4 Method A.	Appearance: No Damage. Contact Resistance: 40 mΩ Max.
Temperature Rise	Mate connector and measure the temperature rise of contact when the maximum rated current is passed and in accordance with EIA-364-70.	+30°C Max. Change allowed.
Thermal Shock	Mate module and subject to follow condition for 10 cycles. At -55°C to +85°C. In accordance with EIA-364-32, test condition I.	No Damage Contact Resistance: 40 mΩ Max. Insulation Resistance: 100 MΩ Min. Dielectric Strength: No Breakdown.
Solderability	Dip solder-tails in flux then immerse in solder bath at 245 ±5°C up to 0.5mm from the bottom of the housing for 4~5 seconds. In accordance with EIA-364-52, category 2.	95% of immersed area must show no voids, pin holes.
Resistance to Soldering Heat (Reflow Soldering)	Sample mounted on PCB and subject to solder bath method, Temperature:260°C for 10±1 sec In accordance with EIA-364-56.	Without deformation of shell or excessive looseness of the terminals (pin.)
Resistance to Soldering Heat (Hand Soldering)	Sample mounted on PCB and subject to hand iron soldering, Temperature:350±10°C for 3±1 sec	Without deformation of shell or excessive looseness of the terminals (pin.)

# PRODUCT SPECIFICATION

<b>Part Number</b>	USB3190	<b>Rev</b>	A	<b>Date</b>	03/08/20
<b>Product Description</b>	Micro USB Receptacle, Type B, Surface Mount , Vertical, Low Profile			<b>Page</b>	5
<b>Doc Number</b>	USB3190	<b>Prepared</b>	<b>CC</b>	<b>Checked</b>	<b>VJ</b>
				<b>Approved</b>	<b>PH</b>

## 7.0 RESISTANCE TO INFRARED REFLOW SOLDERING HEAT

7.1 Lead Free Process: Reflow soldering cycles limited to one time.

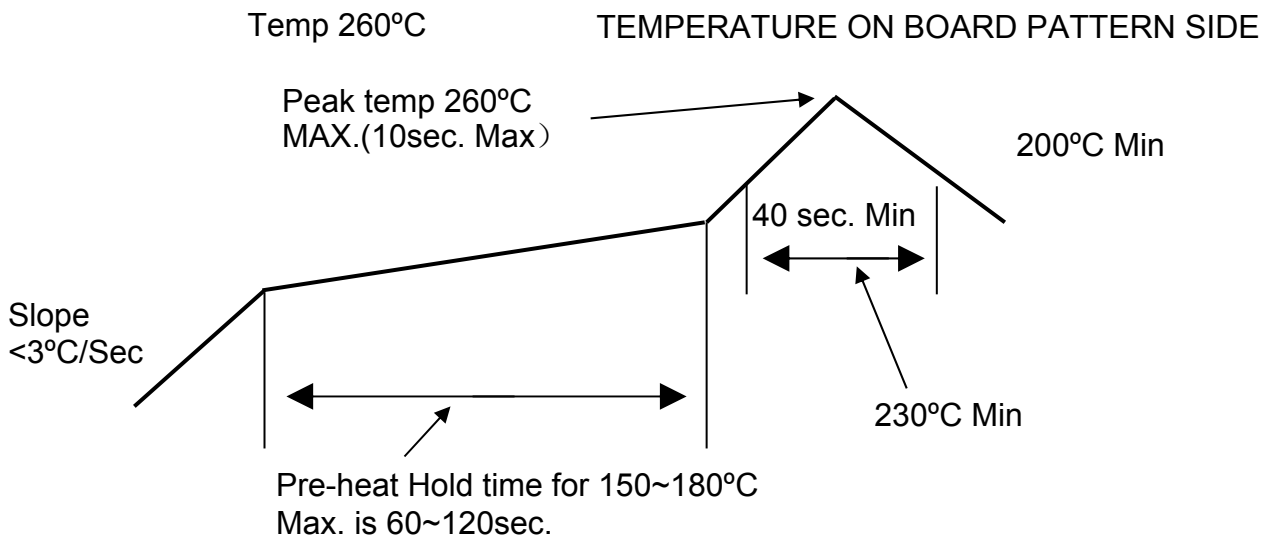

## 8.0 PRODUCT QUALIFICATION AND TEST SEQUENCE

Test Item	Test Group							
	1	2	3	4	5	6	7	8
Examination of Product	1,9	1,8	1,5	1,5	1,3	1,3	1,3	1,3
Contact Resistance	3,7		2,4	2,4				
Insulation Resistance		2,6						
Dielectric Withstanding Voltage		3,7						
Mating / Unmating Forces	2,8							
Durability	4							
Vibration	6							
Mechanical Shock	5							
Humidity		5						
Salt Spray			3					
Temperature Life				3				
Temperature Rise					2			
Thermal Shock		4						
Solderability						2		
Resistance to Reflow Soldering Heat							2	
Resistance to Hand Soldering Heat								2

# PRODUCT SPECIFICATION

<b>Part Number</b>	USB3190	<b>Rev</b>	A	<b>Date</b>	03/08/20		
<b>Product Description</b>	Micro USB Receptacle, Type B, Surface Mount , Vertical, Low Profile			<b>Page</b>	6		
<b>Doc Number</b>	USB3190	<b>Prepared</b>	<b>CC</b>	<b>Checked</b>	<b>VJ</b>	<b>Approved</b>	<b>PH</b>

## Revision details :-

Revision	Information	Page	Release Date
A	Specification released.	-	03/08/20