

38 V, 2 A synchronous step-down switching regulator evaluation board based on the A6986H

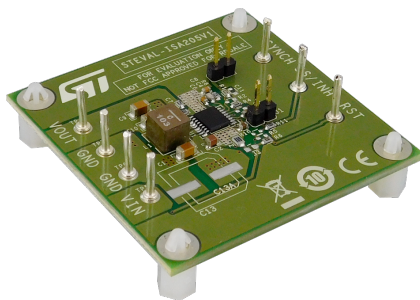

Features

- AECQ100 qualification
- 2 A DC output current
- 4 V to 38 V operating input voltage
- Low consumption mode or low noise mode
- Programmable I_{SKIP} current
- 30 μ A I_Q at light load (LCM $V_{IN} = 12$ V and $V_{OUT} = 3.3$ V)
- 8 μ A $I_{Q-SHTDWN}$
- Adjustable f_{SW} (250 kHz - 2 MHz)
- Output voltage adjustable from 0.85 V to V_{IN}
- Embedded output voltage supervisor
- Synchronization (in all f_{SW} range)
- Adjustable soft-start time
- Internal current limiting
- Overvoltage protection
- Peak current mode architecture
- $R_{DS(on)HS} = 180$ m Ω ; $R_{DS(on)LS} = 150$ m Ω
- Thermal shutdown
- RoHS and WEEE compliant

Product summary

38 V, 2 A synchronous step-down switching regulator evaluation board based on A6986H	STEVAL-ISA205V1
38 V, 2 A synchronous step-down switching regulator with 30 μ A quiescent current	A6986H

Description

The [STEVAL-ISA205V1](#) product evaluation board is based on the synchronous step-down switching regulator [A6986H](#) that can deliver up to 2 A and withstand cold cranking across 100% duty cycle, which, along with its wide input operating voltage range, render the [A6986H](#) the ideal choice for battery powered automotive systems.

Synchronous rectification helps to achieve higher efficiency at full load as well as application compactness, while high-frequency switching (programmable up to 2 MHz) helps to cut power passive costs and size, while staying outside of the AM band.

The device can operate in a Low Consumption Mode (LCM) with a quiescent current down to 30 μ A at $V_{IN} = 12$ V and $V_{OUT} = 3.3$ V, hence assuring high efficiency at light loads, as required in typical car body applications that are active during car parking.

A Low Noise Mode (LNM) is also available to meet the requirements of infotainment applications of forced PWM mode in all loading conditions.

The default configuration of the board is output voltage set to 3.3 V configured in LCM, 500 kHz switching frequency, I_{SKIP} current set to high level and the switchover feature disabled. All of these settings can be easily changed by the user to evaluate different application scenarios.

1 Schematic diagram

Figure 1. STEVAL-ISA205V1 board schematic

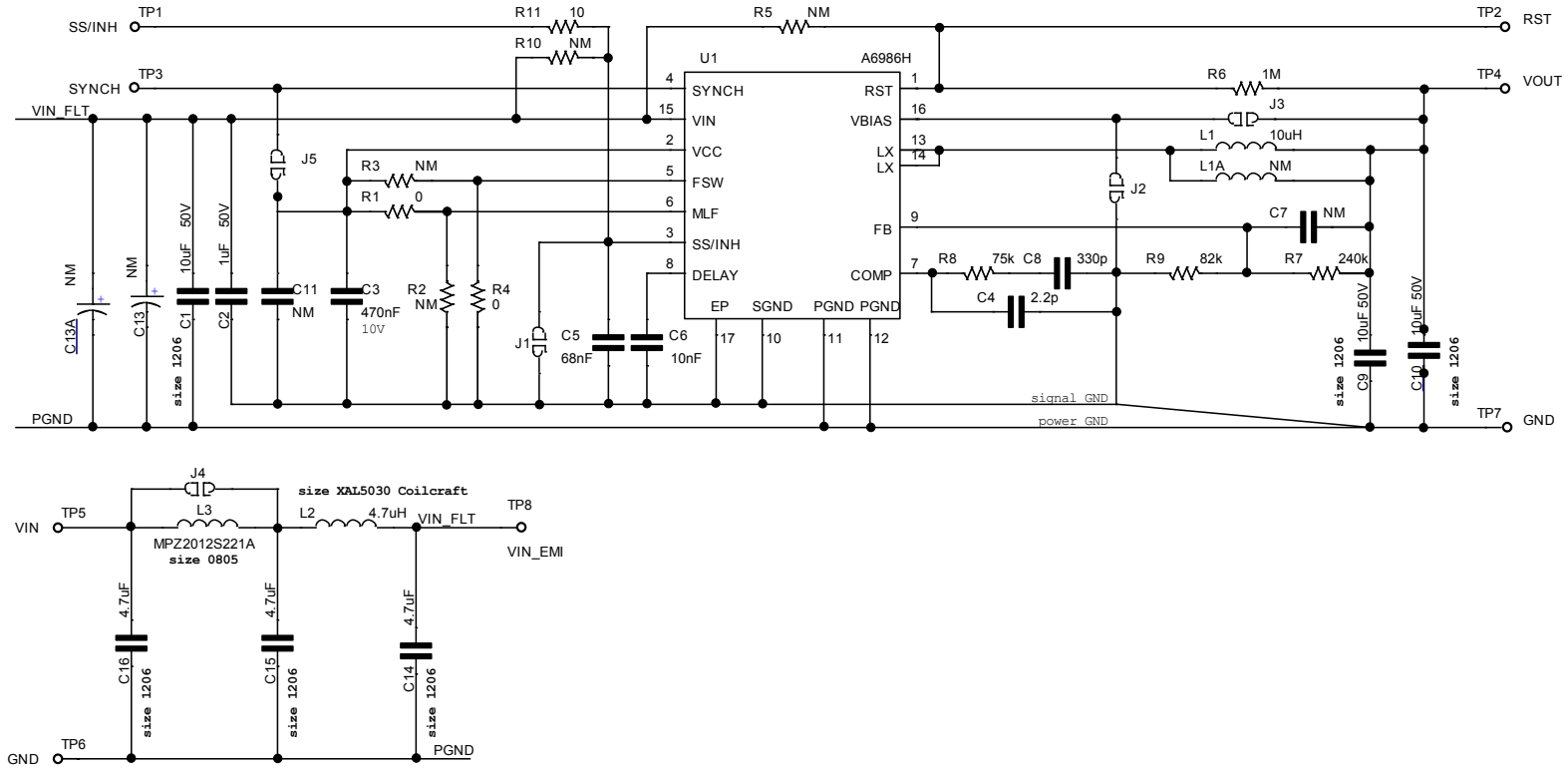

Revision history

Table 1. Document revision history

Date	Version	Changes
02-Apr-2019	1	Initial release.

IMPORTANT NOTICE – PLEASE READ CAREFULLY

STMicroelectronics NV and its subsidiaries (“ST”) reserve the right to make changes, corrections, enhancements, modifications, and improvements to ST products and/or to this document at any time without notice. Purchasers should obtain the latest relevant information on ST products before placing orders. ST products are sold pursuant to ST’s terms and conditions of sale in place at the time of order acknowledgement.

Purchasers are solely responsible for the choice, selection, and use of ST products and ST assumes no liability for application assistance or the design of Purchasers’ products.

No license, express or implied, to any intellectual property right is granted by ST herein.

Resale of ST products with provisions different from the information set forth herein shall void any warranty granted by ST for such product.

ST and the ST logo are trademarks of ST. For additional information about ST trademarks, please refer to www.st.com/trademarks. All other product or service names are the property of their respective owners.

Information in this document supersedes and replaces information previously supplied in any prior versions of this document.

© 2019 STMicroelectronics – All rights reserved