

Mini drone kit with flight controller unit, motors, propellers, frame and battery



Features

- Drone Kit based on the STEVAL-FCU001V1 compact flight controller unit
- Four motors: 85x20 mm, 3.7 V
- Two clockwise and two counterclockwise 65 mm propellers, plus a couple of spares
- LiPo 3.7 V / 600 mAh battery with a maximum discharge current of 30 C
- 3D plastic mechanical frame including propeller guards for safety
- WEEE and RoHS compliant
- Compliant with Directive 2006/66/EC



Description

The **STEVAL-DRONE01** mini drone kit features the high performance **STEVAL-FCU001V1** flight controller unit, as well as the motors, propellers, plastic frame and battery you need to assemble your own mini-drone.

The flight controller unit runs the firmware (**STSW-FCU001**) to control the speed of each connected motor and to stabilize the drone. To achieve this, the **STM32F4** microcontroller hosted on the board analyses data from the accelerometer and gyroscope sensors (LSM6DSL and iNEMO 6DoF inertial measurement unit) to provide highly accurate stability and control.

The FCU board includes a Bluetooth Low Energy **SPBTLE-RF** module, so you can turn your smartphone running a dedicated App into a remote control unit.

Product summary	
STEVAL-DRONE01	Mini drone kit with flight controller unit, motors, propellers, frame and battery
STEVAL-FCU001V1	Flight controller unit evaluation board for toy drones
STSW-FCU001	Reference design firmware for mini drones
STM32F4	High-performance MCUs with DSP and FPU instructions
SPBTLE-RF	Very low power module for Bluetooth Smart v4.1

1 Schematic diagrams

Figure 1. STEVAL-FCU001V1 – block diagram

Figure 2. STEVAL-FCU001V1 – circuit schematic (1 of 4)

Figure 3. STEVAL-FCU001V1 – circuit schematic (2 of 4)

Figure 4. STEVAL-FCU001V1 – circuit schematic (3 of 4)

Figure 5. STEVAL-FCU001V1 – circuit schematic (4 of 4)

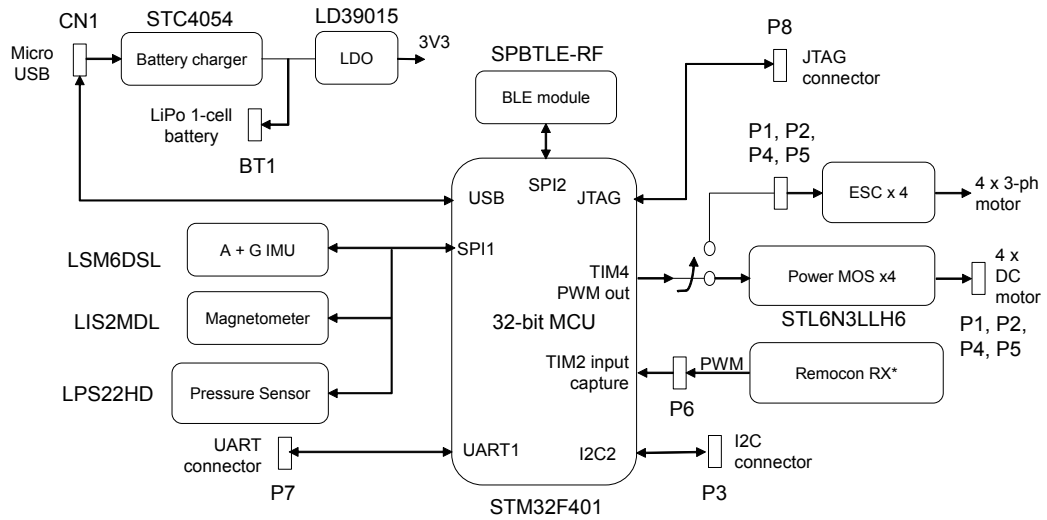
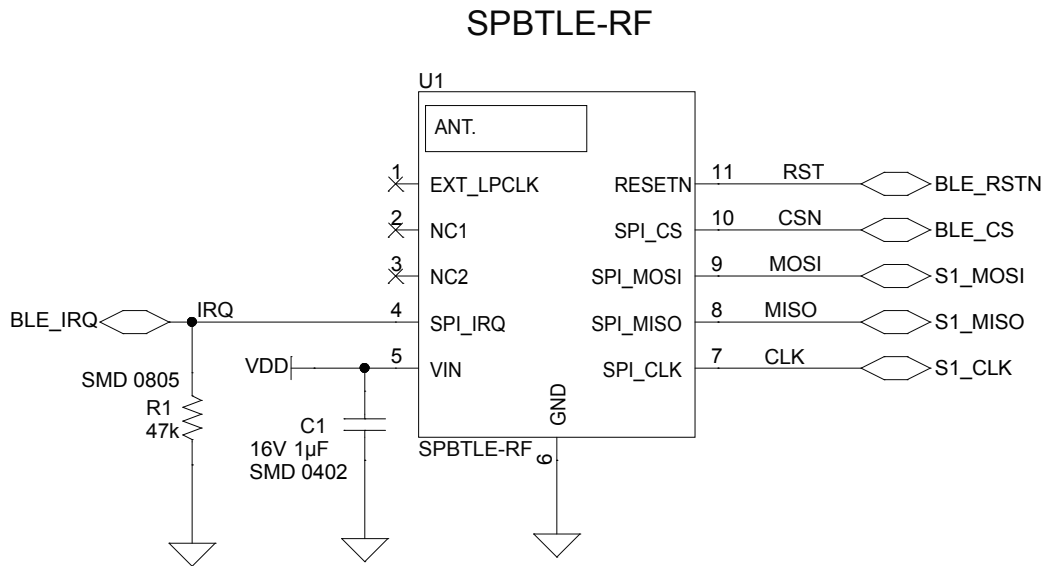
Revision history

Table 1. Document revision history

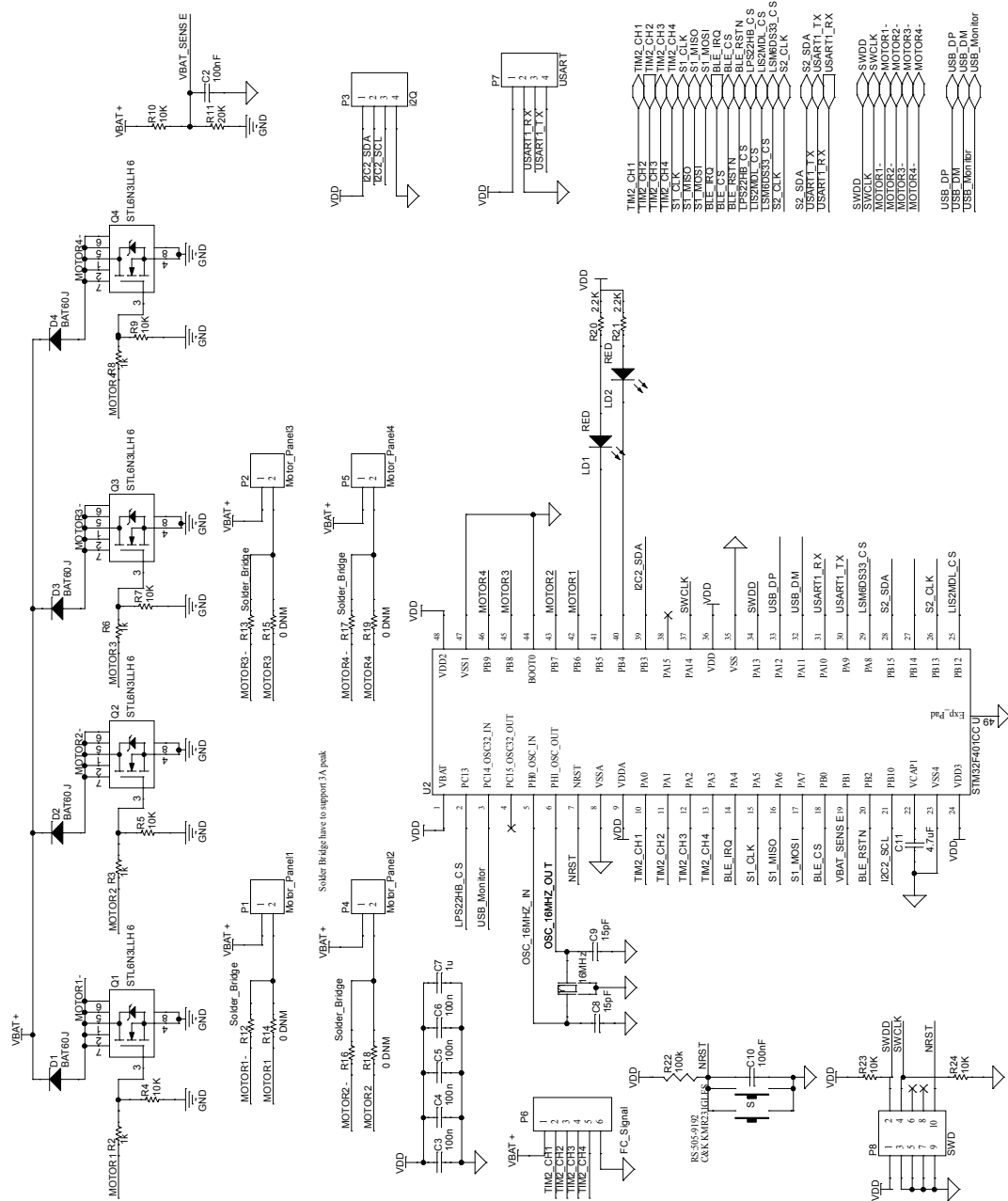
Date	Version	Changes
09-Oct-2018	1	Initial release.
16-Nov-2018	2	Updated cover image

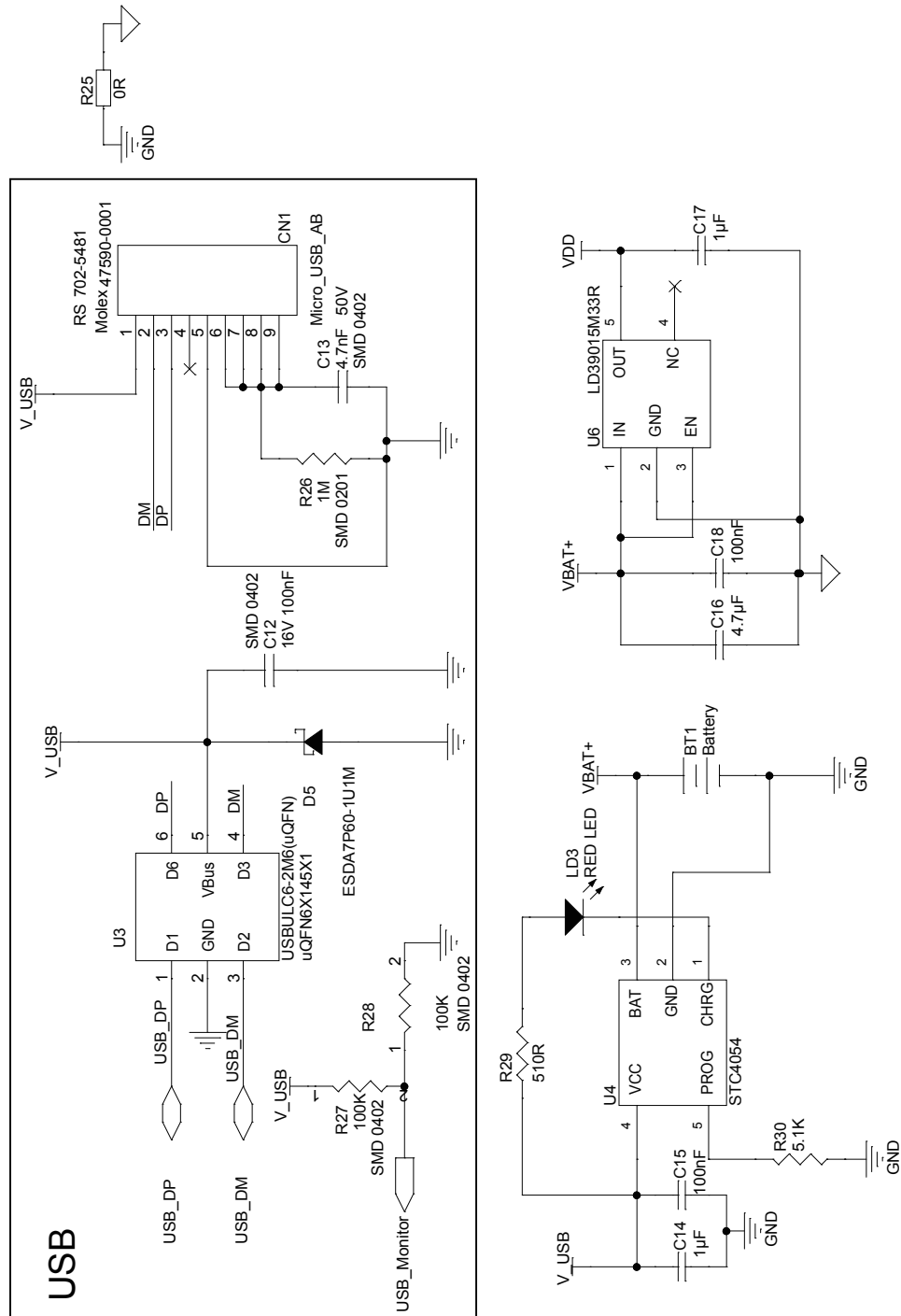
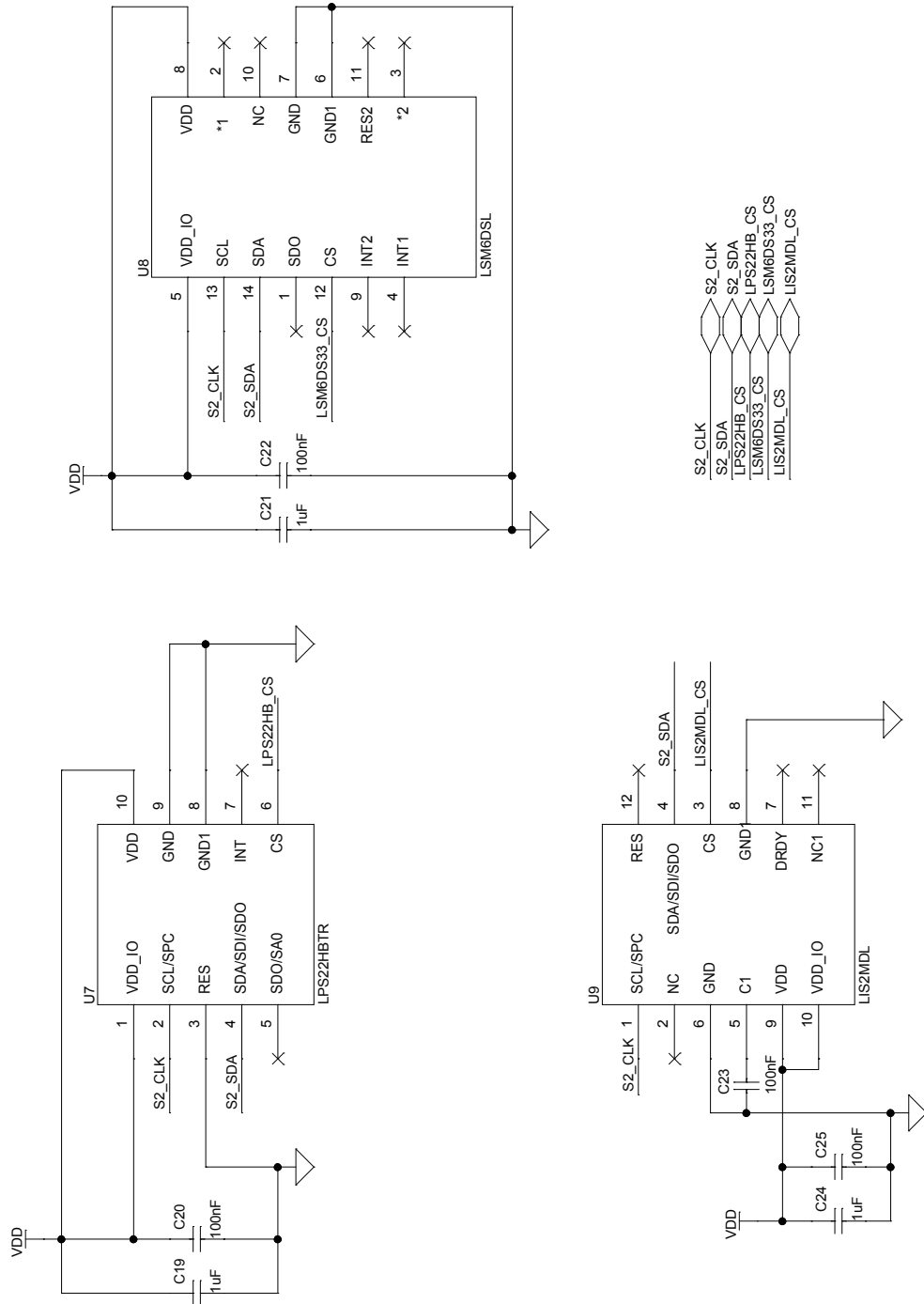
IMPORTANT NOTICE – PLEASE READ CAREFULLY

STMicroelectronics NV and its subsidiaries (“ST”) reserve the right to make changes, corrections, enhancements, modifications, and improvements to ST products and/or to this document at any time without notice. Purchasers should obtain the latest relevant information on ST products before placing orders. ST products are sold pursuant to ST’s terms and conditions of sale in place at the time of order acknowledgement.

Purchasers are solely responsible for the choice, selection, and use of ST products and ST assumes no liability for application assistance or the design of Purchasers’ products.

No license, express or implied, to any intellectual property right is granted by ST herein.

Resale of ST products with provisions different from the information set forth herein shall void any warranty granted by ST for such product.

ST and the ST logo are trademarks of ST. All other product or service names are the property of their respective owners.

Information in this document supersedes and replaces information previously supplied in any prior versions of this document.

© 2018 STMicroelectronics – All rights reserved