

SF2352H

**403.5 MHz
SAW Filter**

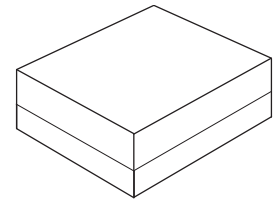

SM2016-4

- 403.5 MHz SAW RF Filter
- 3 MHz Bandwidth
- 2.0 x 1.6 mm Surface-mount Case
- Complies with Directive 2002/95/EC (RoHS)
- Moisture Sensitivity Level: 1
- AEC-Q200 Qualified

Absolute Maximum Ratings

Rating	Value	Units
Maximum Incident Power in Passband	+17	dBm
Maximum DC Voltage On any Non-ground Terminal	3	VDC
Operating Temperature Range	+0 to +55	°C
Storage Temperature Range in Tape and Reel	-20 to +70	°C
Maximum Soldering Temperature Profile (5 cycles maximum)	265 °C for 10 s	

Electrical Characteristics

Characteristic	Sym	Notes	Min	Typ	Max	Units
Center Frequency	f _c			403.50		MHz
Insertion Loss, 402 to 405 MHz (Ripple is included)	IL			2.5	4.0	dB
Bandwidth at -1.5 dB	BW		3.0	5.1		MHz
Amplitude Ripple, 402 to 405 MHz	Δα			0.8	2.0	dB _{P-P}
Attenuation (relative to IL)	α _{rel}					dB
0.3 to 380 MHz			30	52		
380 to 398 MHz			20	28		
412 to 430 MHz			20	27		
430 to 2000 MHz			30	36		
Case			2.0 X 1.6 X .55 mm, 4 Terminals			
Lid Symbolization: (Y = Year, W = Week)		7U, YW				
Terminating Source Impedance: Single-Ended				50		Ω
Terminating Source Impedance: Single-Ended				200		Ω
Temperature Coefficient of Frequency				-36		ppm/°C
Frequency Aging ABS Value First Year					10	ppm/yr
DS Insulation Resistance between Any 2 Pins			1.0			MΩ

Electrical Connections

Connection	Terminals
Input	2
Output	4
Ground	All Others

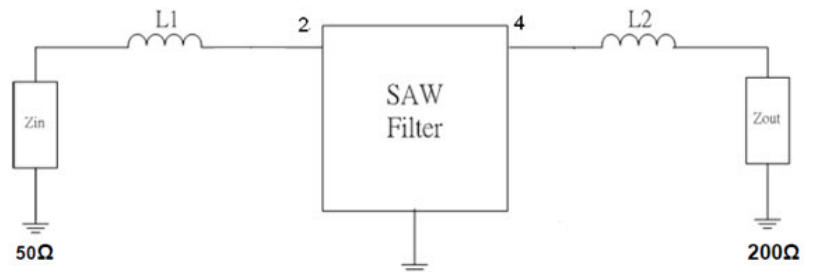

L1=5.6 nH, L2=82 nH



CAUTION: Electrostatic Sensitive Device. Observe precautions for handling.

NOTES:

1. The design, manufacturing process, and specifications of this device are subject to change.
2. US or International patents may apply.
3. RoHS compliant from the first date of manufacture.

Frequency Response Plots

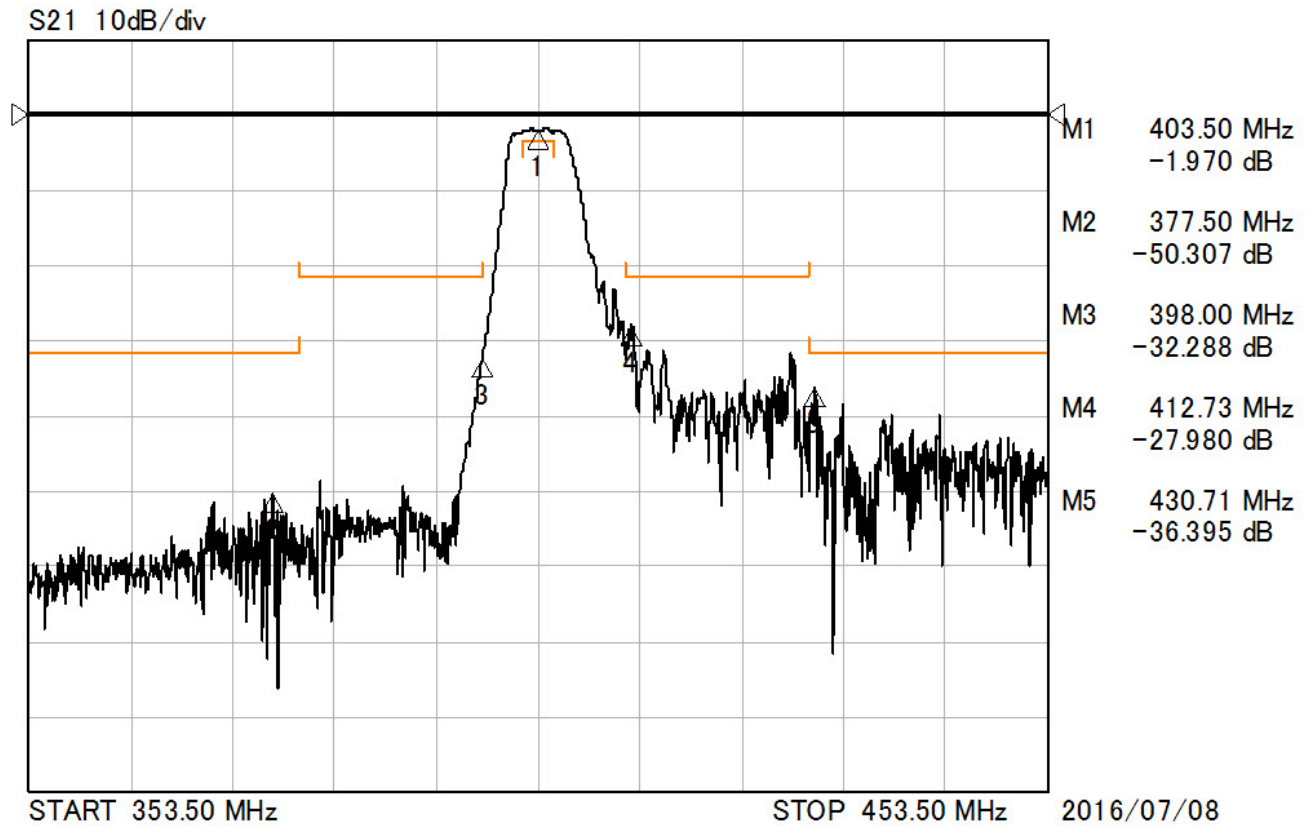
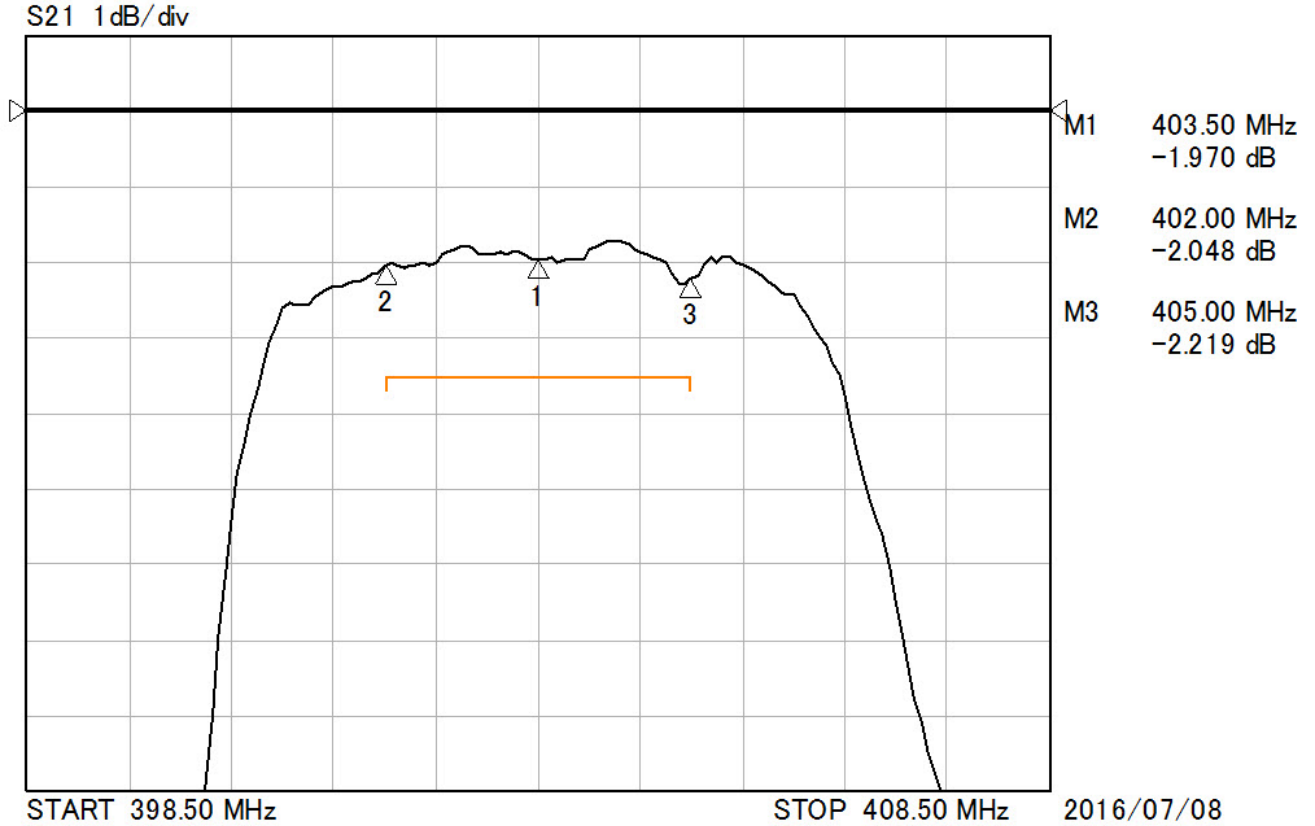

Frequency Response Plots

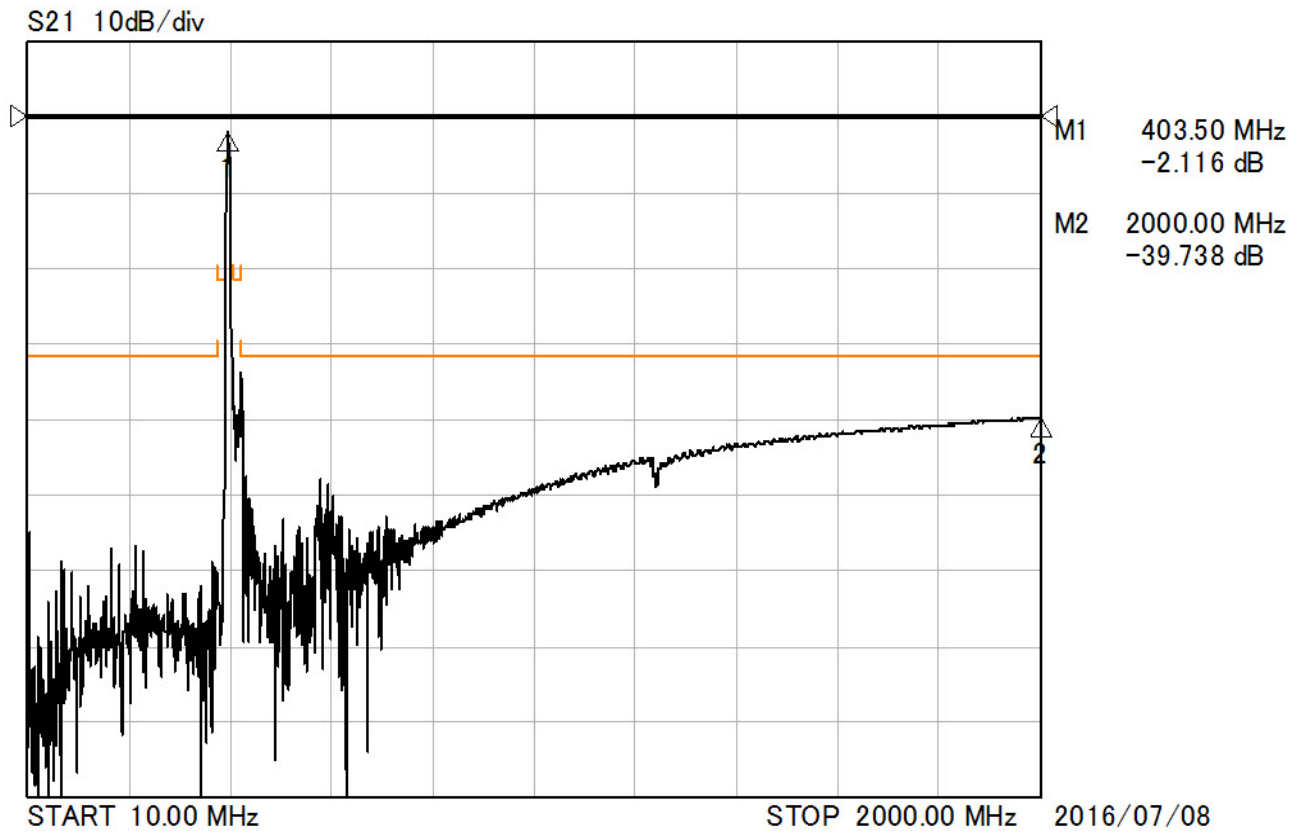

SM2016 - 2.0 X 1.6 mm -Terminal Surface-mount Case Drawing

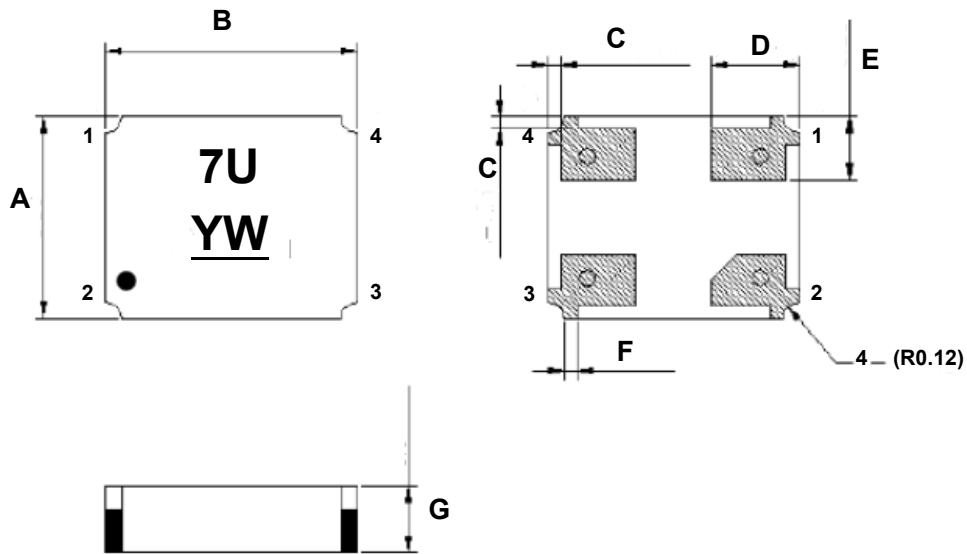

PCB Footprint

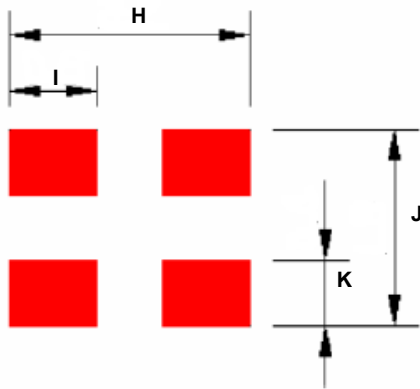

Case and PCB Footprint Dimensions

Dimension	mm			Inches		
	Min	Nom	Max	Min	Nom	Max
A	1.57	1.65	1.73	0.064	0.062	0.068
B	1.97	2.05	2.13	0.077	0.080	0.083
C	-	0.10	-	-	0.003	-
D	0.53	0.70	0.83	0.020	0.027	0.032
E	0.37	0.50	0.63	0.014	0.019	0.024
F	-	0.10	-	-	0.003	-
G	0.55	0.625	0.70	0.024	0.021	0.027
H	-	2.20	-	-	0.086	-
I	-	0.80	-	-	0.031	-
J	-	1.80	-	-	0.070	-
K	-	0.60	-	-	0.023	-

Materials	
Solder Pad Plating	0.3 to 1.0 μm Gold over 1.27 to 8.89 μm Nickel
Lid Plating	1.27 μm (minimum) Nickel over Cold Rolled Steel
Body	Al_2O_3 Ceramic

Reel Dimensions

Reel Count:
 7" = 2000
 13" = 10,000

Tape and Reel Standard per ANSI/EIA-481

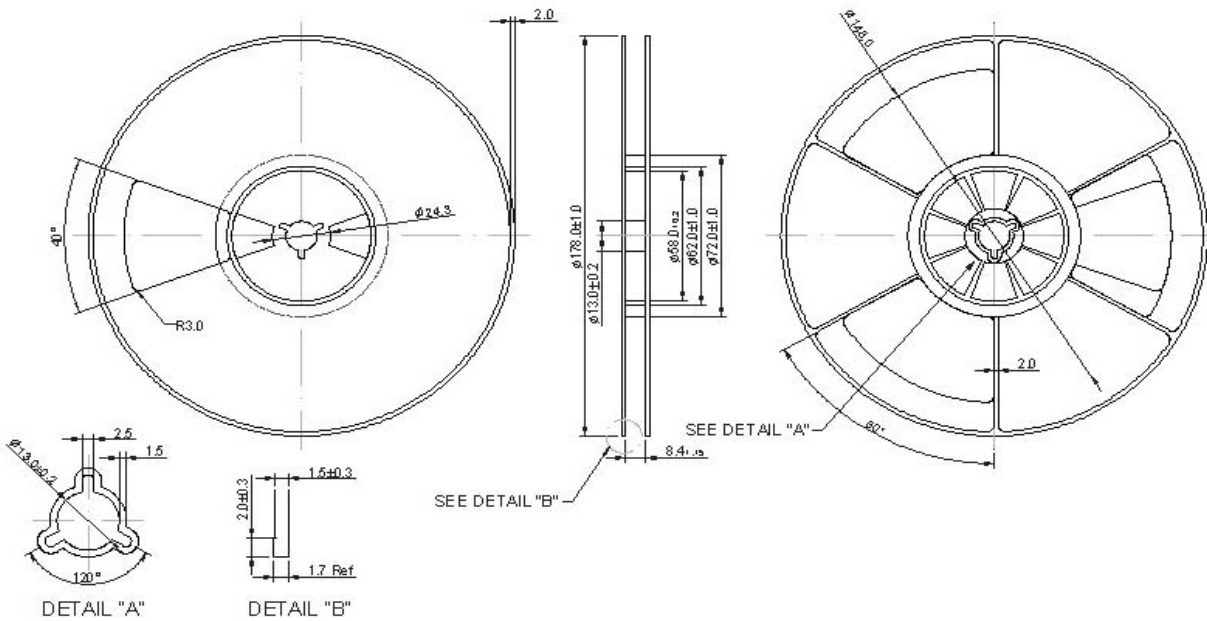

Tape Dimensions

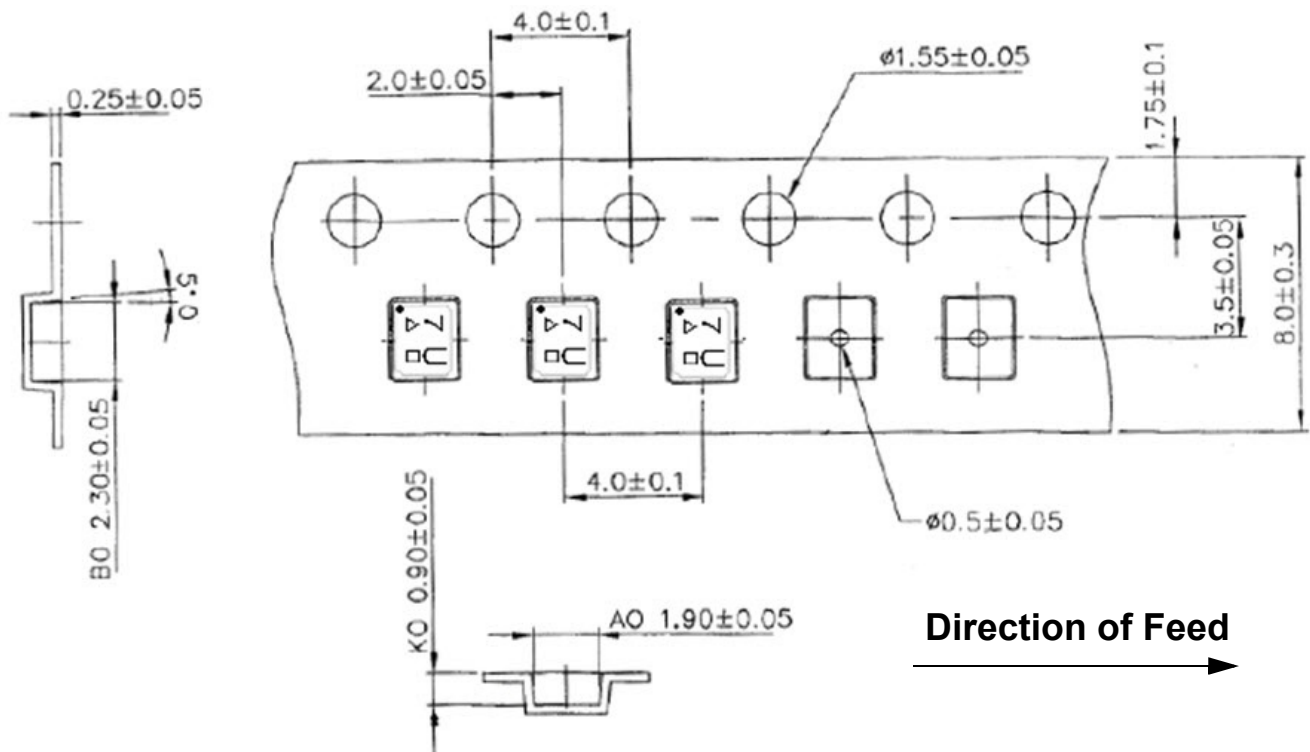

Recommended Reflow Profile

1. Preheating shall be fixed at 150~180°C for 60~90 seconds.
2. Ascending time to preheating temperature 150°C shall be 30 seconds min.
3. Heating shall be fixed at 220°C for 50~80 seconds and at 260°C +0/-5°C peak (10 seconds).
4. Time: 5 times maximum.

