

Silicon carbide Power MOSFET 650 V, 18 mΩ typ., 119 A in an HiP247-4 package

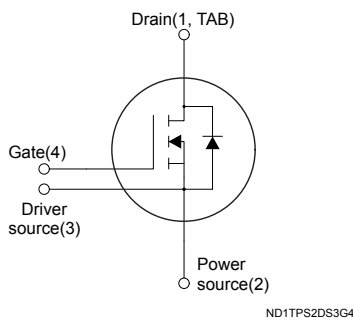
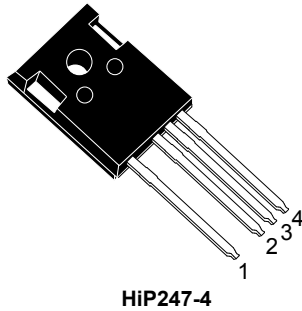

Product status link

[SCTWA90N65G2V-4](#)

Product summary

Order code	SCTWA90N65G2V-4
Marking	SCT90N65G2V
Package	HiP247-4
Packing	Tube

Features

Order code	V_{DS}	$R_{DS(on)}$ typ.	I_D
SCTWA90N65G2V-4	650 V	18 mΩ	119 A

- Very fast and robust intrinsic body diode
- Extremely low gate charge and input capacitance
- Very high operating junction temperature capability ($T_J = 200\text{ °C}$)
- Source sensing pin for increased efficiency

Applications

- Switching mode power supply
- DC-DC converters
- Industrial motor control

Description

This silicon carbide Power MOSFET device has been developed using ST's advanced and innovative 2nd generation SiC MOSFET technology. The device features remarkably low on-resistance per unit area and very good switching performance. The variation of switching loss is almost independent of junction temperature.

1 Electrical ratings

Table 1. Absolute maximum ratings

Symbol	Parameter	Value	Unit
V_{DS}	Drain-source voltage	650	V
V_{GS}	Gate-source voltage	-10 to 22	V
	Gate-source voltage (recommended operating values)	-5 to 18	
I_D	Drain current (continuous) at $T_C = 25\text{ °C}$	119	A
	Drain current (continuous) at $T_C = 100\text{ °C}$	90	
$I_{DM}^{(1)}$	Drain current (pulsed)	220	A
P_{TOT}	Total power dissipation at $T_C = 25\text{ °C}$	565	W
T_{stg}	Storage temperature range	-55 to 200	°C
T_j	Operating junction temperature range		°C

1. Pulse width is limited by safe operating area.

Table 2. Thermal data

Symbol	Parameter	Value	Unit
R_{thJC}	Thermal resistance, junction-to-case	0.31	°C/W
R_{thJA}	Thermal resistance, junction-to-ambient	40	°C/W

2 Electrical characteristics

($T_{CASE} = 25\text{ °C}$ unless otherwise specified).

Table 3. On/off states

Symbol	Parameter	Test conditions	Min.	Typ.	Max.	Unit
$V_{(BR)DSS}$	Drain-source breakdown voltage	$V_{GS} = 0\text{ V}, I_D = 1\text{ mA}$	650			V
I_{DSS}	Zero gate voltage drain current	$V_{DS} = 650\text{ V}, V_{GS} = 0\text{ V}$			10	μA
I_{GSS}	Gate-body leakage current	$V_{DS} = 0\text{ V}, V_{GS} = -10\text{ to }22\text{ V}$			± 100	nA
$V_{GS(th)}$	Gate threshold voltage	$V_{DS} = V_{GS}, I_D = 1\text{ mA}$	1.9	3.2	5.0	V
$R_{DS(on)}$	Static drain-source on-resistance	$V_{GS} = 18\text{ V}, I_D = 50\text{ A}$		18	24	m Ω
		$V_{GS} = 18\text{ V}, I_D = 50\text{ A}, T_J = 200\text{ °C}$		30		

Table 4. Dynamic, based on HiP247 package option

Symbol	Parameter	Test conditions	Min.	Typ.	Max.	Unit
C_{iss}	Input capacitance	$V_{DS} = 400\text{ V}, f = 1\text{ MHz}, V_{GS} = 0\text{ V}$	-	3380	-	pF
C_{oss}	Output capacitance		-	294	-	
C_{rss}	Reverse transfer capacitance		-	49	-	
Q_g	Total gate charge	$V_{DD} = 400\text{ V}, I_D = 50\text{ A},$ $V_{GS} = -5\text{ V to }18\text{ V}$	-	157	-	nC
Q_{gs}	Gate-source charge		-	43	-	
Q_{gd}	Gate-drain charge		-	42	-	
R_g	Gate input resistance	$f = 1\text{ MHz}, I_D = 0\text{ A}$	-	1	-	Ω

Table 5. Switching energy (inductive load), based on HiP247 package option

Symbol	Parameter	Test conditions	Min.	Typ.	Max.	Unit
E_{on}	Turn-on switching energy	$V_{DD} = 400\text{ V}, I_D = 50\text{ A}, R_G = 2.2\text{ }\Omega,$ $V_{GS} = -5\text{ to }18\text{ V}$	-	130	-	μJ
E_{off}	Turn-off switching energy		-	210	-	
E_{on}	Turn-on switching energy	$V_{DD} = 400\text{ V}, I_D = 50\text{ A}, R_G = 2.2\text{ }\Omega,$ $V_{GS} = -5\text{ to }18\text{ V}, T_J = 200\text{ °C}$	-	135	-	
E_{off}	Turn-off switching energy		-	200	-	

Table 6. Switching times, based on HiP247 package option

Symbol	Parameter	Test conditions	Min.	Typ.	Max.	Unit
$t_{d(on)}$	Turn-on delay time	$V_{DD} = 400\text{ V}, I_D = 50\text{ A},$ $R_G = 2.2\text{ }\Omega, V_{GS} = -5\text{ V to }18\text{ V},$	-	26	-	ns
t_f	Fall time		-	38	-	
$t_{d(off)}$	Turn-off delay time		-	58	-	
t_r	Rise time		-	16	-	

Table 7. Reverse SiC diode characteristics, based on HiP247 package option

Symbol	Parameter	Test conditions	Min.	Typ.	Max.	Unit
V_{SD}	Forward on voltage	$I_F = 30\text{ A}$, $V_{GS} = 0\text{ V}$	-	2.5	-	V
t_{rr}	Reverse recovery time	$I_F = 50\text{ A}$, $di/dt = 4000\text{ A}/\mu\text{s}$, $V_{GS} = V_{GS} = -5\text{ V to }18\text{ V}$, $V_{DD} = 400\text{ V}$, $T_J = 25\text{ }^\circ\text{C}$	-	17	-	ns
Q_{rr}	Reverse recovery charge		-	308	-	nC
I_{RRM}	Reverse recovery current		-	30	-	A

2.1 Electrical characteristics (curves), based on HiP247 package option
Figure 1. Safe operating area

Figure 2. Maximum transient thermal impedance

Figure 3. Typical output characteristics (T_J = -50 °C)

Figure 4. Typical output characteristics (T_J = 25 °C)

Figure 5. Typical output characteristics (T_J = 200 °C)

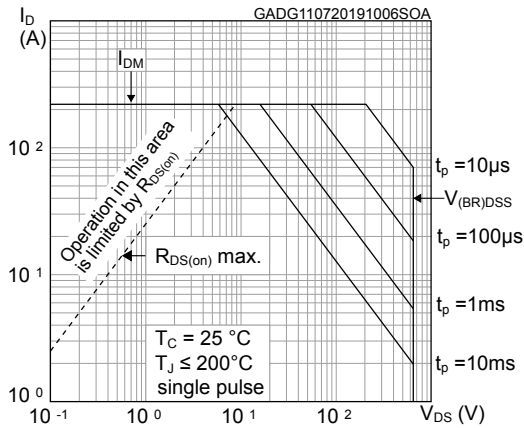
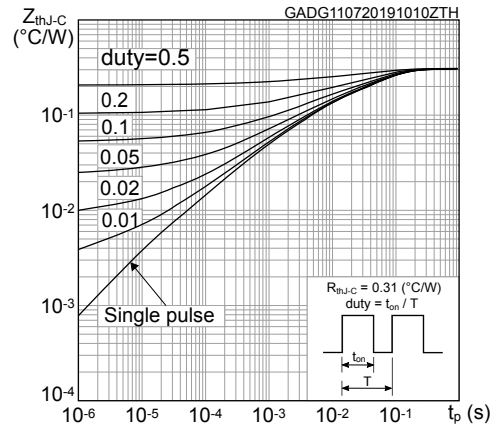
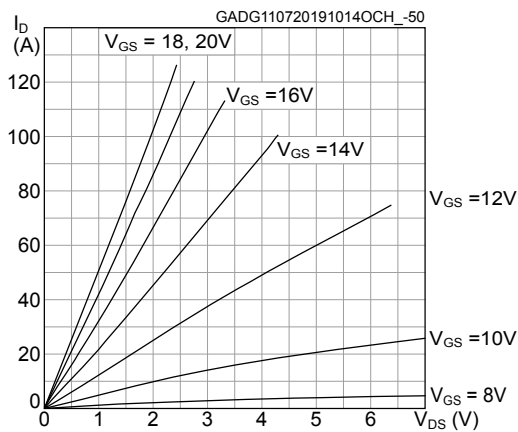
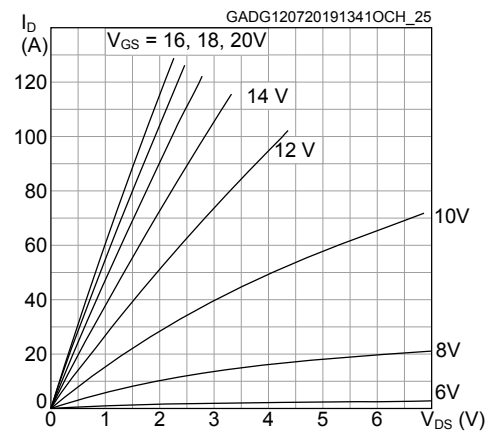
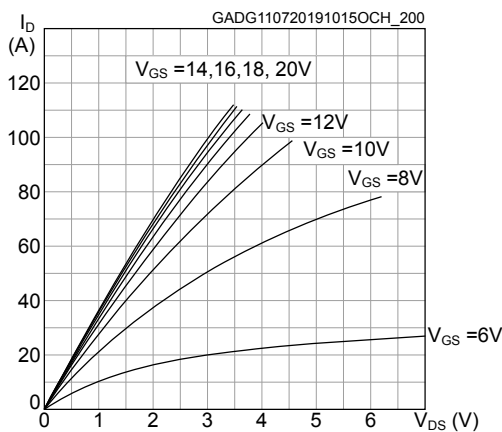
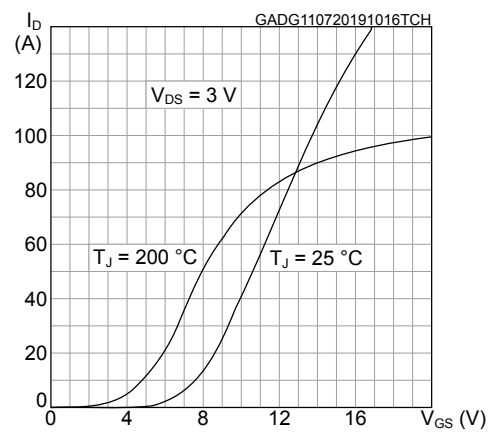
Figure 6. Typical transfer characteristics

Figure 7. Typical capacitances

Figure 8. Typical gate charge

Figure 9. Maximum total power dissipation

Figure 10. Typical drain-source on-resistance

Figure 11. Normalized on-resistance vs temperature

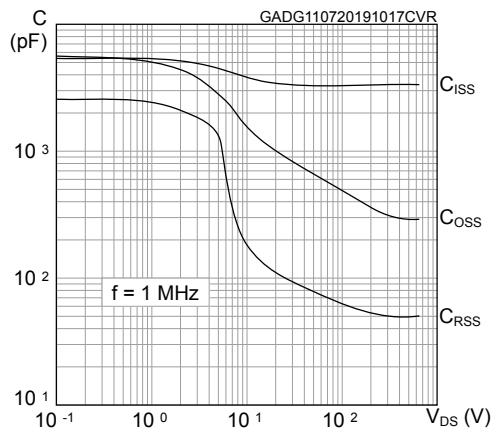
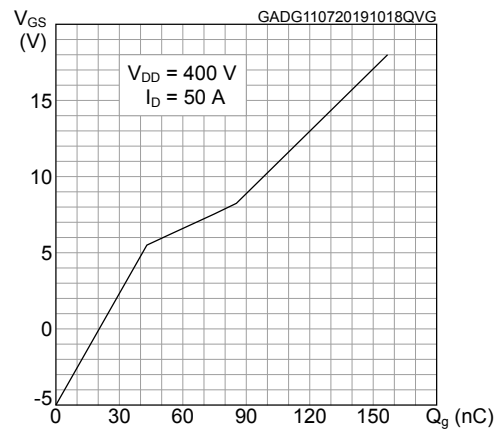
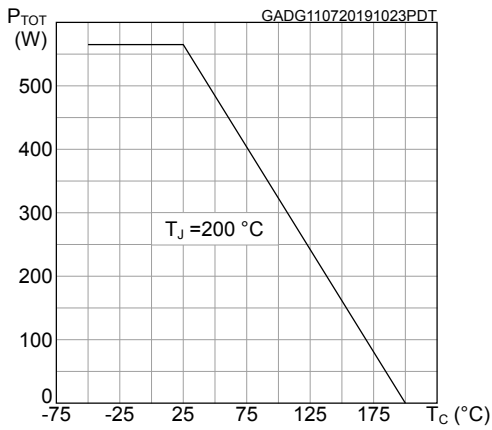
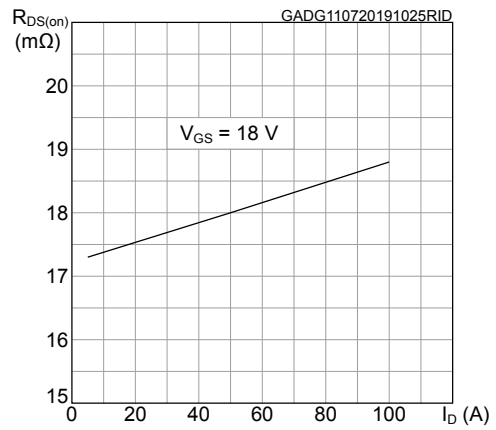
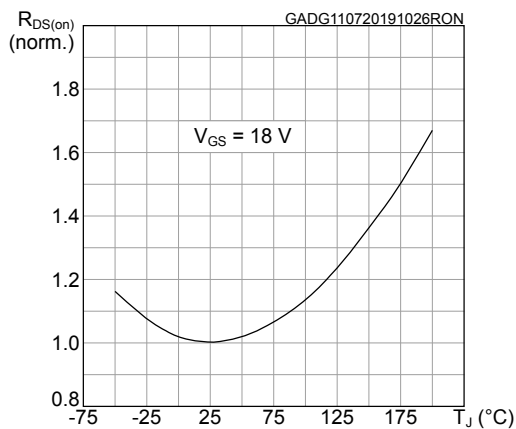
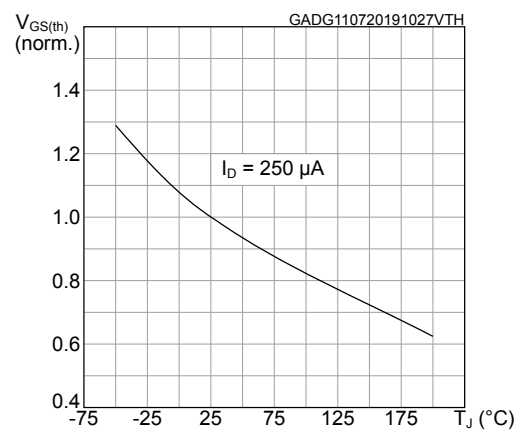
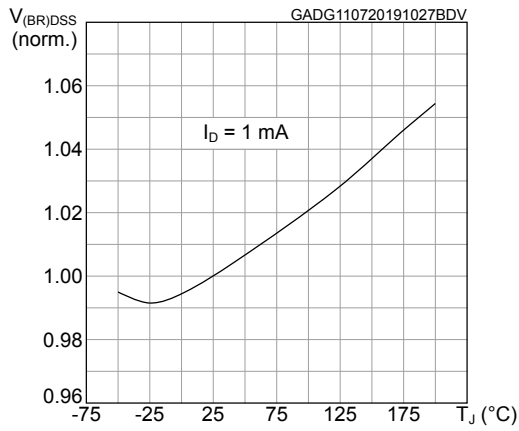
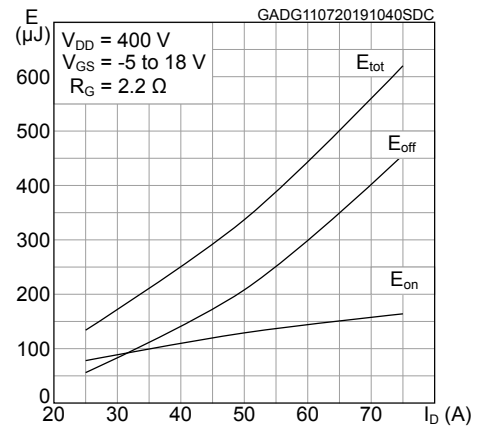
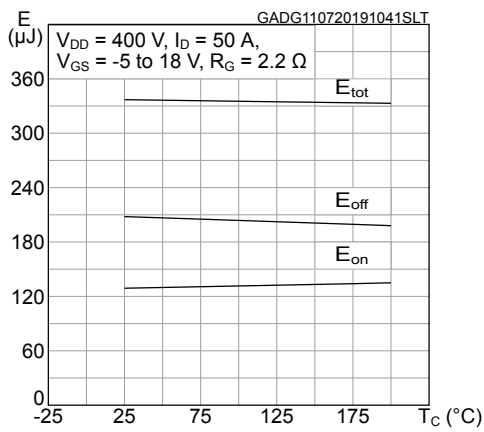
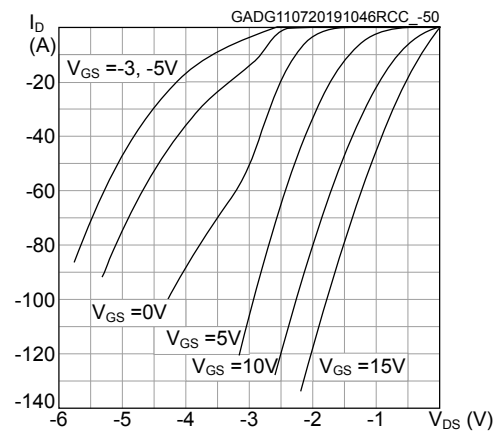
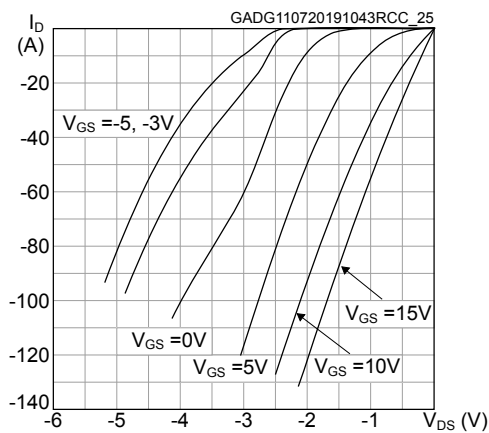
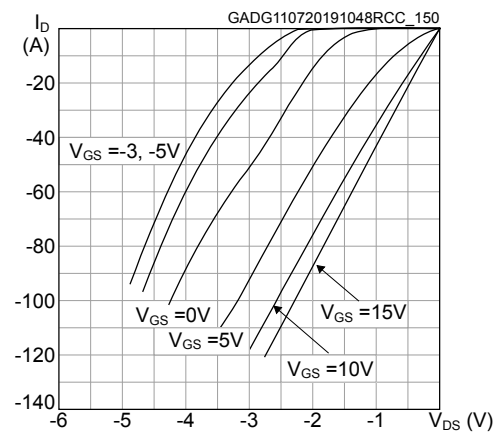
Figure 12. Normalized gate threshold voltage vs temperature

Figure 13. Normalized breakdown voltage vs temperature

Figure 14. Typical switching energy vs drain current

Figure 15. Typical switching energy vs temperature

Figure 16. Typical reverse conduction characteristics (Tj = -50 °C)

Figure 17. Typical reverse conduction characteristics (Tj = 25 °C)

Figure 18. Typical reverse conduction characteristics (Tj = 150 °C)

3 Package information

In order to meet environmental requirements, ST offers these devices in different grades of **ECOPACK** packages, depending on their level of environmental compliance. ECOPACK specifications, grade definitions and product status are available at: www.st.com. ECOPACK is an ST trademark.

3.1 HiP247-4 package information

Figure 19. HiP247-4 package outline

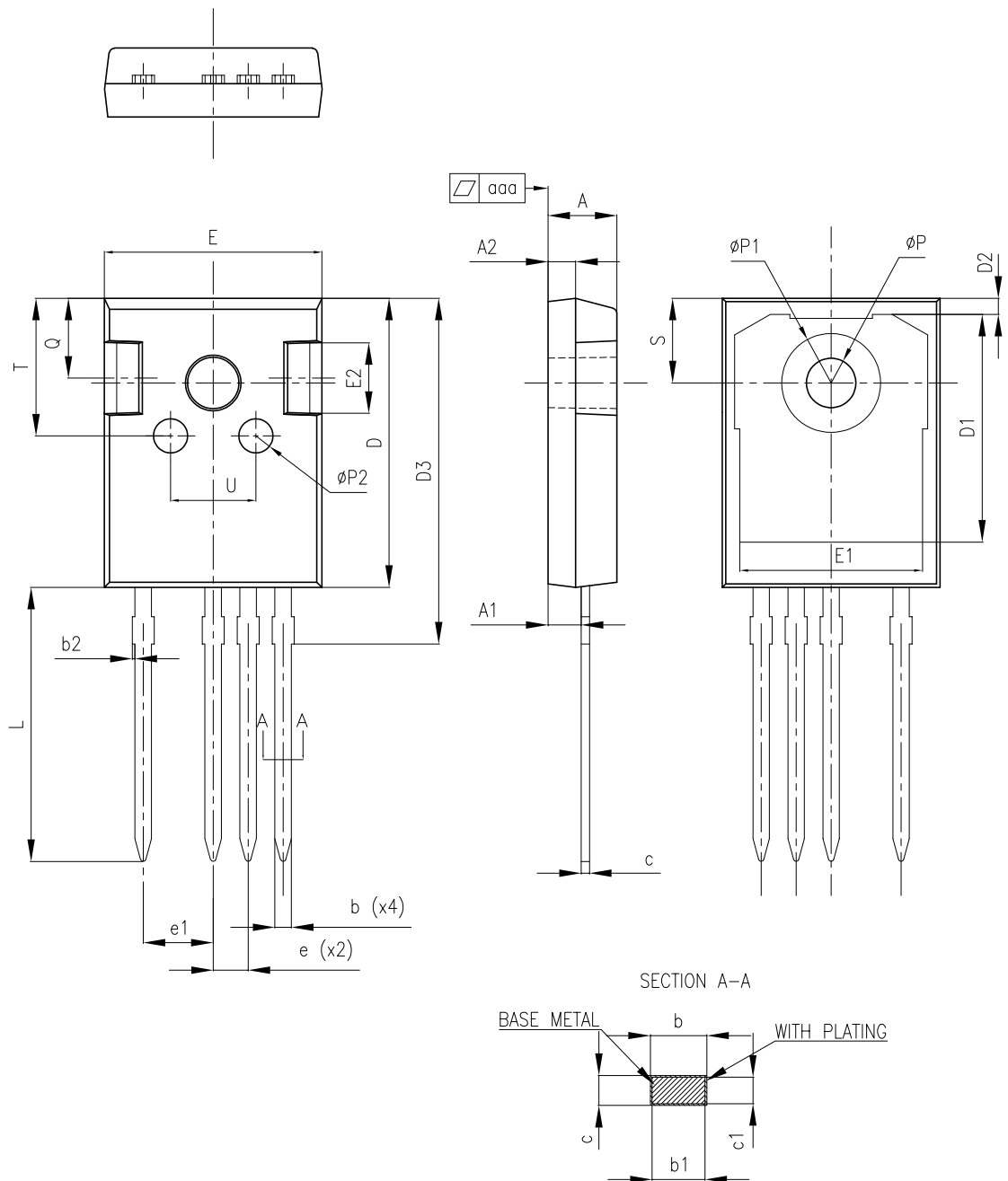

Table 8. HiP247-4 mechanical data

Dim.	mm		
	Min.	Typ.	Max.
A	4.90	5.00	5.10
A1	2.31	2.41	2.51
A2	1.90	2.00	2.10
b	1.16		1.29
b1	1.15	1.20	1.25
b2	0		0.20
c	0.59		0.66
c1	0.58	0.60	0.62
D	20.90	21.00	21.10
D1	16.25	16.55	16.85
D2	1.05	1.20	1.35
D3	24.97	25.12	25.27
E	15.70	15.80	15.90
E1	13.10	13.30	13.50
E2	4.90	5.00	5.10
E3	2.40	2.50	2.60
e	2.44	2.54	2.64
e1	4.98	5.08	5.18
L	19.80	19.92	20.10
P	3.50	3.60	3.70
P1			7.40
P2	2.40	2.50	2.60
Q	5.60		6.00
S		6.15	
T	9.80		10.20
U	6.00		6.40
aaa		0.04	0.10

Revision history

Table 9. Document revision history

Date	Revision	Changes
25-Nov-2020	1	First release.
16-Aug-2023	2	Updated Features on cover page. Updated Table 6. Switching times , based on HiP247 package option. Updated Section 3 Package information .

Contents

1	Electrical ratings	2
2	Electrical characteristics	3
2.1	Electrical characteristics (curves), based on HiP247 package option	5
3	Package information	8
3.1	HiP247-4 package information	8
	Revision history	10

IMPORTANT NOTICE – READ CAREFULLY

STMicroelectronics NV and its subsidiaries (“ST”) reserve the right to make changes, corrections, enhancements, modifications, and improvements to ST products and/or to this document at any time without notice. Purchasers should obtain the latest relevant information on ST products before placing orders. ST products are sold pursuant to ST’s terms and conditions of sale in place at the time of order acknowledgment.

Purchasers are solely responsible for the choice, selection, and use of ST products and ST assumes no liability for application assistance or the design of purchasers’ products.

No license, express or implied, to any intellectual property right is granted by ST herein.

Resale of ST products with provisions different from the information set forth herein shall void any warranty granted by ST for such product.

ST and the ST logo are trademarks of ST. For additional information about ST trademarks, refer to www.st.com/trademarks. All other product or service names are the property of their respective owners.

Information in this document supersedes and replaces information previously supplied in any prior versions of this document.

© 2023 STMicroelectronics – All rights reserved