

Pb THIS PRODUCT MANUFACTURED WITH LEAD-FREE PROCESSING

DESIGNED & DIMENSIONED IN MILLIMETERS [INCHES]

DO NOT SCALE FROM THIS PRINT

RF178-XXXXX-XXXXXX-XXXX

CABLE CALLOUT
178: RG178 CABLE (CCA-178)

OVERALL ASSEMBLY LENGTH (OAL)
XXXX (MILLIMETERS) (0100 MIN)
(SEE NOTE 8)

END 1 CONNECTOR
(SEE TABLE 3, SHEET 2)

END 2 CONNECTOR OR PREPARATION
(SEE TABLE 3, SHEET 2)

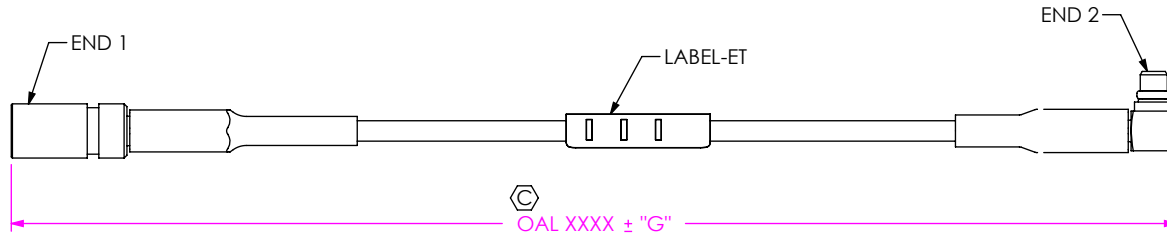

FIG 1
RF178-02SJX-03RPX-XXXX SHOWN

OVERALL LENGTH	"G"
0100-0200 [3.92-7.87]	+3.0 [.12]/-0.0 [.00]
0200-0500 [7.87-19.69]	+5.0 [.20]/-0.0 [.00]
0500-1000 [19.69-43.30]	+10.0 [.40]/-0.0 [.00]

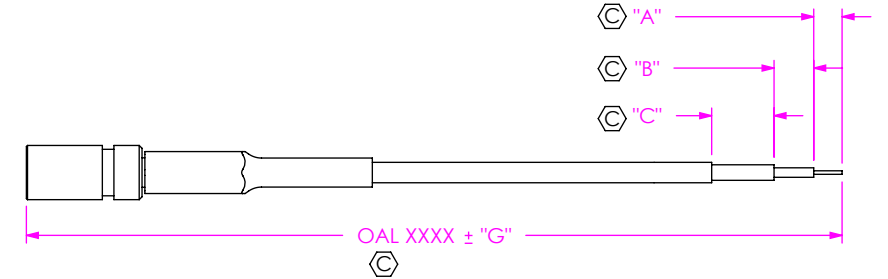

FIG 1
RF178-02SJX-350969-XXXX SHOWN (SEE NOTE 5 & 7)

"C" FORMAT: X.X
"B" FORMAT: X.X
"A" FORMAT: X.X

DO NOT LEAVE ANY SPACE BLANK,
EACH MUST CONTAIN A
NUMERIC CHARACTER 0 THRU 9

F:\DWG\MISC\MKTG\RF178-XXXX-XXXXXX-XXXX-MKT.SLDDRW

UNLESS OTHERWISE SPECIFIED, DIMENSIONS ARE IN MILLIMETERS [INCHES].
TOLERANCES ARE:
DECIMALS ANGLES
.X: ±0.3 [.01] 2°
.XX: ±0.13 [.005]
.XXX: ±0.051 [.0020]

PROPRIETARY NOTE
THIS DOCUMENT CONTAINS CONFIDENTIAL AND PROPRIETARY INFORMATION AND ALL DESIGN, MANUFACTURING, REPRODUCTION, USE, PATENT RIGHTS AND SALES RIGHTS ARE EXPRESSLY RESERVED BY SAMTEC, INC. THIS DOCUMENT SHALL NOT BE DISCLOSED, IN WHOLE OR PART, TO ANY UNAUTHORIZED PERSON OR ENTITY NOR REPRODUCED, TRANSFERRED OR INCORPORATED IN ANY OTHER PROJECT IN ANY MANNER WITHOUT THE EXPRESS WRITTEN CONSENT OF SAMTEC, INC.

MATERIAL: DO NOT SCALE DRAWING SHEET SCALE: 3:2
NUTS, LOCK WASHERS, COUPLING NUTS,
SHELLS, FERRULES, CONTACTS, CAPS: COPPER ALLOY
INSULATORS: PTFE
GASKETS: SILICONE
C-RINGS, FLAT WASHERS: FE
SPRING WASHERS: STAINLESS STEEL



520 PARK EAST BLVD. NEW ALBANY, IN 47150
PHONE: 812-944-6733 FAX: 812-948-5047
e-Mail info@SAMTEC.com code 55322

DESCRIPTION: RG178 CABLE ASSEMBLY

DWG. NO. RF178-XXXXX-XXXXXX-XXXX

BY: TIM P. 5/6/2005 SHEET 1 OF 12

- NOTES:
- ⊕ REPRESENTS A CRITICAL DIMENSION
 - ⊕ ASSEMBLY TO BE 100% TESTED FOR OPENS, SHORTS & HI-POT TESTED (PER TABLE 3, AC OR DC), THE HI-POST VOLTAGE FOR THE ASSEMBLY SHOULD BE SET TO THE END OPTION WITH THE LOWEST TEST VOLTAGE RATING.
 - AFTER FINAL ELECTRICAL TEST, LABEL EACH CABLE ASSEMBLY WITH 1 LABEL-ET
 - FINISHED ASSEMBLIES TO BE PACKAGED PER PACKAGING STANDARD CO-RF-WI-3040-M. ASSEMBLIES WITH LOCKWASHERS, NUTS, AND GASKETS TO BE SHIPPED KITTED AS ONE ASSEMBLY PER BAG, UNASSEMBLED.
 - DIM "A", "B", AND "C" HAVE A MINIMUM VALUE OF 0.0mm & A MAXIMUM VALUE OF 9.9mm
 - CONNECTORS TO BE ORIENTED ACCORDING TO CO-RF-WI-3048-M.
 - FOR STRIPPED AND TINNED OPTION, ONLY THE CENTER CONDUCTOR IS TINNED.
 - CABLE LENGTHS LONGER THAN 1000 MILLIMETERS ARE NOT SUPPORTED BY S.I. TEST DATA

TABLE 1

END OPTION	SUBTRACT OR	STRIP DIMENSIONS					HI POT	
		"Y"	"A"	"D"	"E"	"F"	"DC"	"AC"
-01BJ1	9.0 [0.35]	2.5 [0.10]	6.7 [0.26]	13.1 [0.52]	3.45 [0.136]	1000	1000	
-01BR1	9.4 [0.37]	2.5 [0.10]	6.7 [0.26]	13.1 [0.52]	3.45 [0.136]	1000	1000	
-01SB1	9.0 [0.35]	2.5 [0.10]	6.7 [0.26]	13.1 [0.52]	3.45 [0.136]	1000	1000	
-01SR1	9.4 [0.37]	2.5 [0.10]	6.7 [0.26]	13.1 [0.52]	3.45 [0.136]	1000	1000	
-02SJ1	6.1 [0.24]	3.5 [0.14]	4.4 [0.17]	11.3 [0.44]	3.45 [0.136]	1000	1000	
-02RP1	1.9 [0.07]	2.1 [0.08]	4.5 [0.18]	9.1 [0.36]	2.79 [0.110]	1000	1000	
-02SP1	7.4 [0.29]	1.8 [0.07]	1.8 [0.07]	9.0 [0.35]	3.45 [0.136]	630	1000	
-03SP1	4.2 [0.17]	2.0 [0.08]	4.6 [0.18]	9.4 [0.37]	2.79 [0.110]	630	500	
-03RPX	1.5 [0.06]	1.8 [0.07]	2.9 [0.11]	7.9 [0.31]	2.79 [0.110]	1000	500	
-04SP1	10.7 [0.42]	3.0 [0.12]	5.0 [0.20]	11.6 [0.46]	3.45 [0.136]	1000	1000	
-04SP2								
-04BJ2	15.0 [0.59]	3.0 [0.12]	5.8 [0.23]	12.8 [0.50]	3.45 [0.136]	1000	1000	
-05BJ3	15.0 [0.59]	3.0 [0.12]	5.8 [0.23]	12.8 [0.50]	3.45 [0.136]	1000	1000	
-06BJ2	17.3 [0.68]	4.5 [0.18]	8.7 [0.34]	16.5 [0.65]	4.52 [0.178]	1000	1000	
-07BJ2	7.7 [0.30]	3.0 [0.12]	4.4 [0.17]	10.5 [0.41]	3.45 [0.136]	1000	1000	
-07BJ4								
*-SING	0.0 [0.00]	-	-	-	N/A	1000	N/A	
*-XXXXXX	0.0 [0.00]	"A"	"A"+"B"	"A"+"B"+"C"	N/A	1000	N/A	

* = END 2 OPTION ONLY

TABLE 3

END OPTION	SERIES	GENDER	CONFIGURATION	PLATING			FIGURE
				CENTER CONTACT	OUTER CONTACT	OTHER COMPONENTS	
-01BJ1	SMA	JACK	STRAIGHT BULKHEAD	30u" GOLD	3u" GOLD	3u" GOLD	SHT 3, FIG 3
-01BR1	SMA	REVERSED POLARITY JACK	STRAIGHT BULKHEAD	30u" GOLD	3u" GOLD	3u" GOLD	SHT 3, FIG 4
-01SB1	SMA	JACK	STRAIGHT BULKHEAD SEALED	30u" GOLD	3u" GOLD	3u" GOLD	SHT 4, FIG 5
-01SR1	SMA	REVERSED POLARITY JACK	STRAIGHT BULKHEAD SEALED	30u" GOLD	3u" GOLD	3u" GOLD	SHT 4, FIG 6
-02SJ1	MCX	JACK	STRAIGHT	30u" GOLD	3u" GOLD	3u" GOLD	SHT 5, FIG 7
-02RP1	MCX	PLUG	RIGHT ANGLE	30u" GOLD	3u" GOLD	3u" GOLD	SHT 5, FIG 8
-02SP1	MCX	PLUG	STRAIGHT	30u" GOLD	3u" GOLD	3u" GOLD	SHT 6, FIG 9
-03SP1	MMCX	PLUG	STRAIGHT	30u" GOLD	3u" GOLD	3u" GOLD	SHT 6, FIG 10
-03RP1	MMCX	PLUG	RIGHT ANGLE	30u" GOLD	3u" GOLD	3u" GOLD	SHT 7, FIG 11
-04SP2	BNC	PLUG	STRAIGHT	30u" GOLD	100u" NICKEL	100u" NICKEL	SHT 7, FIG 12
-04SP3	BNC	PLUG	STRAIGHT	10u" GOLD	100u" NICKEL	100u" NICKEL	
-04BJ2	BNC	JACK	STRAIGHT BULKHEAD	30u" GOLD	100u" NICKEL	100u" NICKEL	SHT 8, FIG 13
-05BJ3	TNC	JACK	STRAIGHT BULKHEAD	30u" GOLD	100u" NICKEL	100u" NICKEL	SHT 9, FIG 16
-06BJ2	NTPE	JACK	STRAIGHT BULKHEAD	30u" GOLD	100u" NICKEL	100u" NICKEL	
-07BJ2	SMB	JACK	STRAIGHT BULKHEAD	30u" GOLD	100u" NICKEL	100u" NICKEL	SHT 10, FIG 17
-07BJ4	SMB	JACK	STRAIGHT BULKHEAD	10u" GOLD	3u" GOLD	100u" NICKEL	
*-SING	SINGLE ENDED	-	-	-	-	-	-
*-XXXXXX	STRIPPED & TINNED	-	-	-	-	-	SHT 1, FIG 2

* = END 2 OPTION ONLY

F:\DWG\MISC\MKTG\RF178-XXXX-XXXX-XXXX-MKT.SLDDRW

PROPRIETARY NOTE
 THIS DOCUMENT CONTAINS CONFIDENTIAL AND PROPRIETARY INFORMATION AND ALL DESIGN, MANUFACTURING, REPRODUCTION, USE, PATENT RIGHTS AND SALES RIGHTS ARE EXPRESSLY RESERVED BY SAMTEC, INC. THIS DOCUMENT SHALL NOT BE DISCLOSED, IN WHOLE OR PART, TO ANY UNAUTHORIZED PERSON OR ENTITY NOR REPRODUCED, TRANSFERRED OR INCORPORATED IN ANY OTHER PROJECT IN ANY MANNER WITHOUT THE EXPRESS WRITTEN CONSENT OF SAMTEC, INC.



520 PARK EAST BLVD, NEW ALBANY, IN 47150
 PHONE: 812-944-6733 FAX: 812-948-5047
 e-Mail info@SAMTEC.com code 55322

DO NOT SCALE DRAWING

SHEET SCALE: 2:1

DESCRIPTION:
RG178 CABLE ASSEMBLY

DWG. NO.
RF178-XXXX-XXXX-XXXX

BY: TIM P. 5/6/2005 SHEET 2 OF 12

FIG 3
-01BJ1 SHOWN

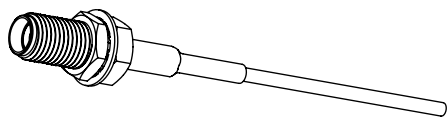
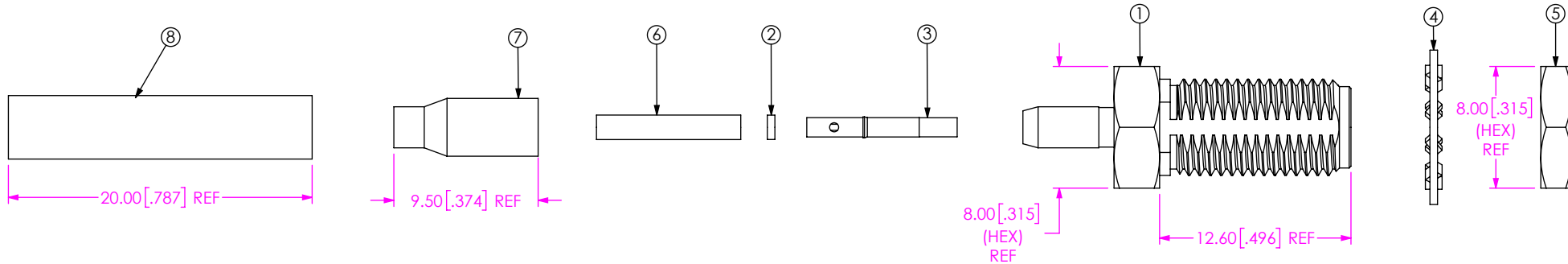

BOM		
ITEM	COMPONENT	-01BJ1
1	SUB-ASSEMBLY	SUB-SMA-J-C-F-ST-BH1
2	INSULATOR	SMA-INS-001
3	PIN	SMA-SKT-002-H
4	LOCK WASHER	SMA-LWAS-001-F
5	NUT	SMA-NUT-001-F
6	INNER FERRULE	SMA-FER-003-N
7	OUTER FERRULE	MCX-FER-004-F
8	HEAT SHRINK	HST-0.125-02-BLK

FIG 4
-01BR1 SHOWN

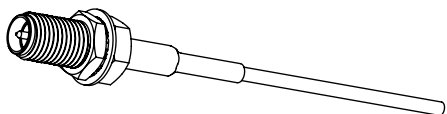
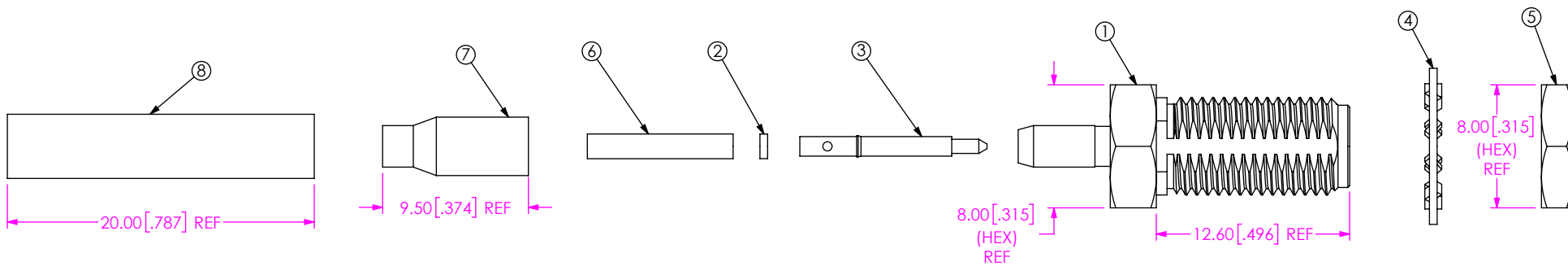

BOM		
ITEM	COMPONENT	-01BR1
1	SUB-ASSEMBLY	SUB-SMA-J-C-F-ST-BH1
2	INSULATOR	SMA-INS-001
3	PIN	SMA-PIN-005-H
4	LOCK WASHER	SMA-LWAS-001-F
5	NUT	SMA-NUT-001-F
6	INNER FERRULE	SMA-FER-003-N
7	OUTER FERRULE	MCX-FER-004-F
8	HEAT SHRINK	HST-0.125-02-BLK

F:\DWG\MISC\MKTG\RF178-XXXXX-XXXXX-MKT.SLDDRW

PROPRIETARY NOTE
THIS DOCUMENT CONTAINS CONFIDENTIAL AND PROPRIETARY INFORMATION AND ALL DESIGN, MANUFACTURING, REPRODUCTION, USE, PATENT RIGHTS AND SALES RIGHTS ARE EXPRESSLY RESERVED BY SAMTEC, INC. THIS DOCUMENT SHALL NOT BE DISCLOSED, IN WHOLE OR PART, TO ANY UNAUTHORIZED PERSON OR ENTITY NOR REPRODUCED, TRANSFERRED OR INCORPORATED IN ANY OTHER PROJECT IN ANY MANNER WITHOUT THE EXPRESS WRITTEN CONSENT OF SAMTEC, INC.

DO NOT SCALE DRAWING

SHEET SCALE: 5:2



520 PARK EAST BLVD, NEW ALBANY, IN 47150
PHONE: 812-944-6733 FAX: 812-948-5047
e-Mail info@SAMTEC.com code 55322

DESCRIPTION: RG178 CABLE ASSEMBLY

DWG. NO. RF178-XXXXX-XXXXX-XXXX

BY: TIM P. 5/6/2005 SHEET 3 OF 12

FIG 5
-01SB1 SHOWN

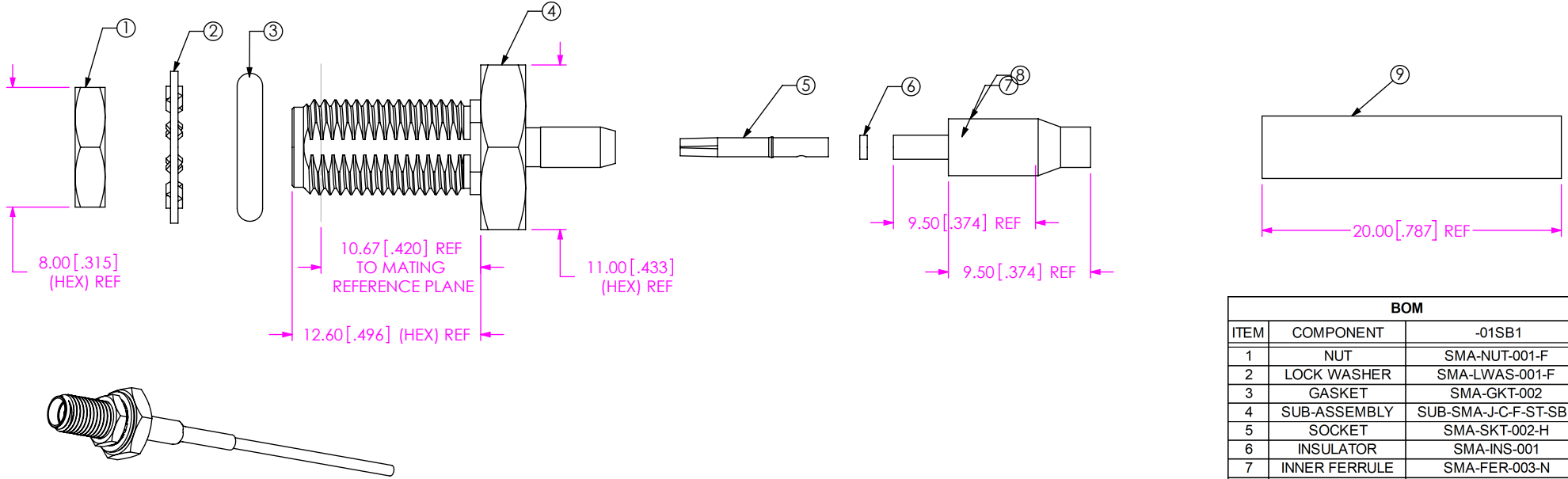

BOM		
ITEM	COMPONENT	-01SB1
1	NUT	SMA-NUT-001-F
2	LOCK WASHER	SMA-LWAS-001-F
3	GASKET	SMA-GKT-002
4	SUB-ASSEMBLY	SUB-SMA-J-C-F-ST-SB1
5	SOCKET	SMA-SKT-002-H
6	INSULATOR	SMA-INS-001
7	INNER FERRULE	SMA-FER-003-N
8	OUTER FERRULE	MCX-FER-004-F
9	HEAT SHRINK	HST-0.125-02-BLK

FIG 6
-01SR1 SHOWN

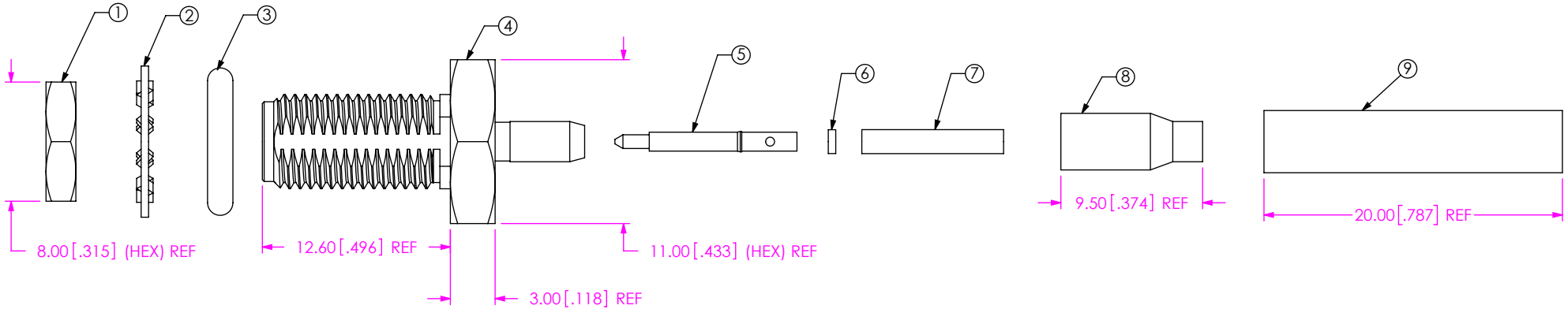

BOM		
ITEM	COMPONENT	-01SR1
1	NUT	SMA-NUT-001-F
2	LOCK WASHER	SMA-LWAS-001-F
3	GASKET	SMA-GKT-002
4	SUB-ASSEMBLY	SUB-SMA-J-C-F-ST-SB1
5	PIN	SMA-PIN-005-H
6	INSULATOR	SMA-INS-001
7	INNER FERRULE	SMA-FER-003-N
8	OUTER FERRULE	MCX-FER-004-F
9	HEAT SHRINK	HST-0.125-02-BLK

F:\DWG\MISC\MKTG\RF178-XXXXX-XXXXX-MKT.SLDDRW

PROPRIETARY NOTE
THIS DOCUMENT CONTAINS CONFIDENTIAL AND PROPRIETARY INFORMATION AND ALL DESIGN, MANUFACTURING, REPRODUCTION, USE, PATENT RIGHTS AND SALES RIGHTS ARE EXPRESSLY RESERVED BY SAMTEC, INC. THIS DOCUMENT SHALL NOT BE DISCLOSED, IN WHOLE OR PART, TO ANY UNAUTHORIZED PERSON OR ENTITY NOR REPRODUCED, TRANSFERRED OR INCORPORATED IN ANY OTHER PROJECT IN ANY MANNER WITHOUT THE EXPRESS WRITTEN CONSENT OF SAMTEC, INC.

DO NOT SCALE DRAWING

SHEET SCALE: 5:2



520 PARK EAST BLVD, NEW ALBANY, IN 47150
PHONE: 812-944-6733 FAX: 812-948-5047
e-Mail info@SAMTEC.com code 55322

DESCRIPTION: RG178 CABLE ASSEMBLY

DWG. NO. RF178-XXXXX-XXXXX-XXXX

BY: TIM P. 5/6/2005 SHEET 4 OF 12

FIG 7
-02SJ1 SHOWN

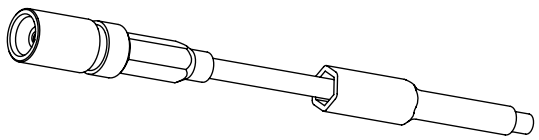
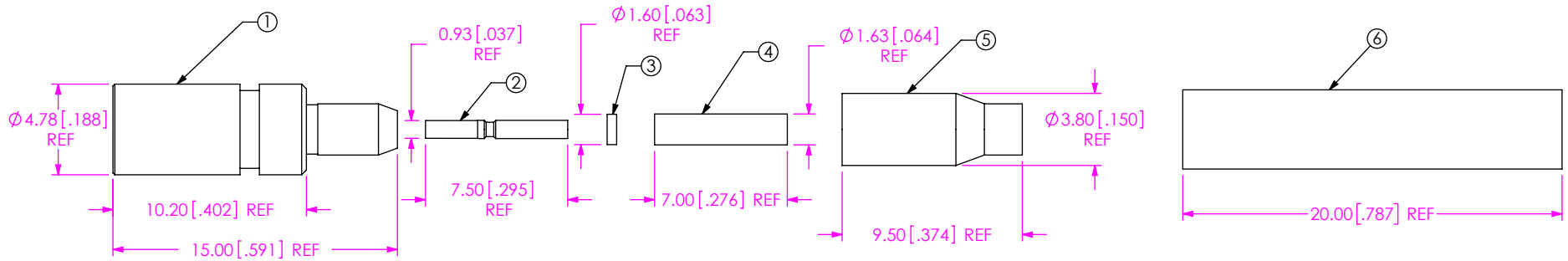

BOM		
ITEM	COMPONENT	-02SJ1
1	SUB ASSEMBLY	SUB-MCX-J-C-F-ST-CA2
2	SOCKET	MCX-SKT-002-H
3	INSULATOR	MCX-INS-002
4	INNER FERRULE	MCX-FER-003-F
5	FERRULE	MCX-FER-004-F
6	HEAT SHRINK	HST-0.125-02-BLK

FIG8
-02RP1 SHOWN

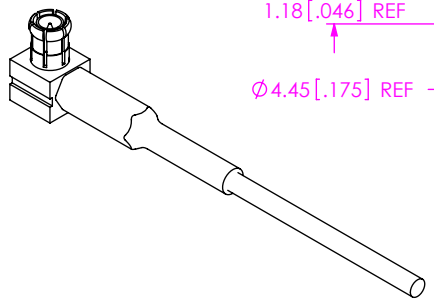
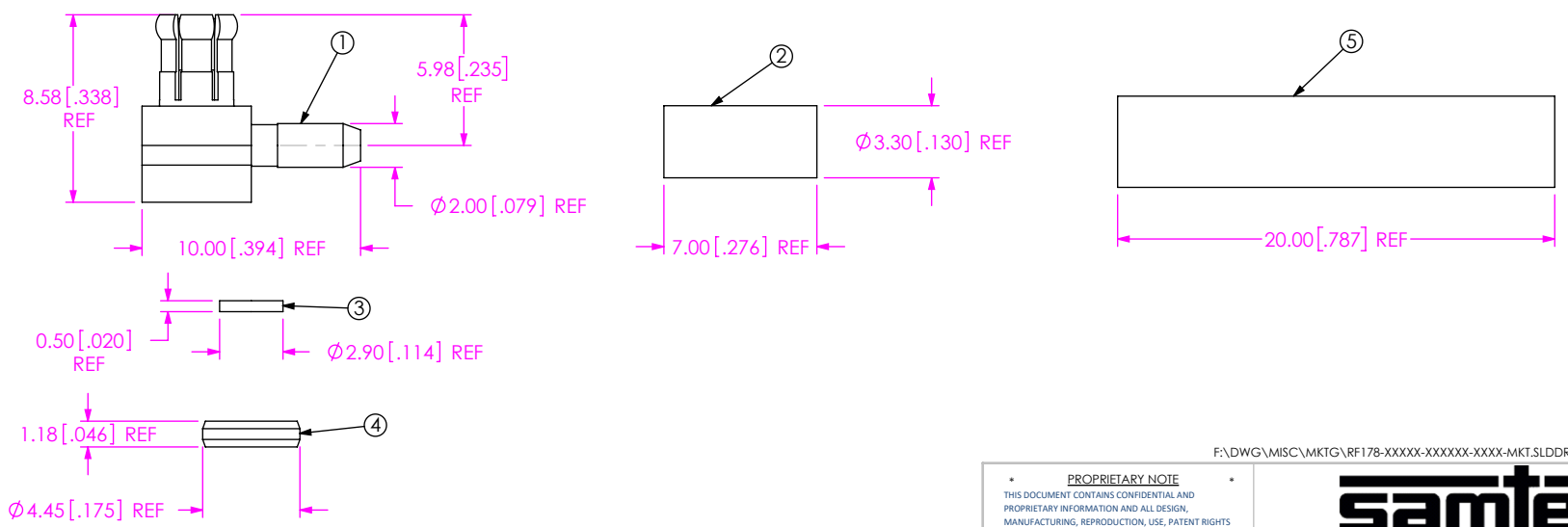

BOM		
ITEM	COMPONENT	-02RP1
1	SUB ASSEMBLY	SUB-MCX-P-C-H-RA-CA2
2	FERRULE	MCX-FER-005-F
3	INSULATOR	MCX-INS-001
4	CAP	MCX-CAP-002-F
5	HEAT SHRINK	HST-0.125-02-BLK

F:\DWG\MISC\MKTG\RF178-XXXX-XXXX-XXXX-MKT.SLDDRW

<p>PROPRIETARY NOTE</p> <p>THIS DOCUMENT CONTAINS CONFIDENTIAL AND PROPRIETARY INFORMATION AND ALL DESIGN, MANUFACTURING, REPRODUCTION, USE, PATENT RIGHTS AND SALES RIGHTS ARE EXPRESSLY RESERVED BY SAMTEC, INC. THIS DOCUMENT SHALL NOT BE DISCLOSED, IN WHOLE OR PART, TO ANY UNAUTHORIZED PERSON OR ENTITY NOR REPRODUCED, TRANSFERRED OR INCORPORATED IN ANY OTHER PROJECT IN ANY MANNER WITHOUT THE EXPRESS WRITTEN CONSENT OF SAMTEC, INC.</p> <p>DO NOT SCALE DRAWING</p> <p>SHEET SCALE: 3:1</p>	 <p>520 PARK EAST BLVD. NEW ALBANY, IN 47150 PHONE: 812-944-6733 FAX: 812-948-5047 e-Mail info@SAMTEC.com code 55322</p>		
	DESCRIPTION: RG178 CABLE ASSEMBLY		
	DWG. NO. RF178-XXXX-XXXX-XXXX		
	BY: TIM P.	5/6/2005	SHEET 5 OF 12

FIG9
-02SP1 SHOWN



BOM		
ITEM	COMPONENT	-02SP1
1	SUB ASSEMBLY	SUB-MCX-P-C-F-ST-CA1
2	PIN	MCX-PIN-002-H
3	INSULATOR	MCX-INS-002
4	INNER FERRULE	MCX-FER-003-F
5	OUTER FERRULE	MCX-FER-004-F
6	HEAT SHRINK	HST-0.125-02-BLK

FIG 10
-03SP1 SHOWN

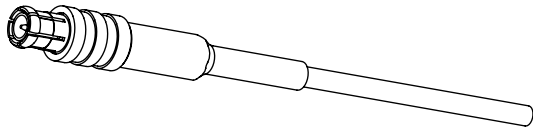
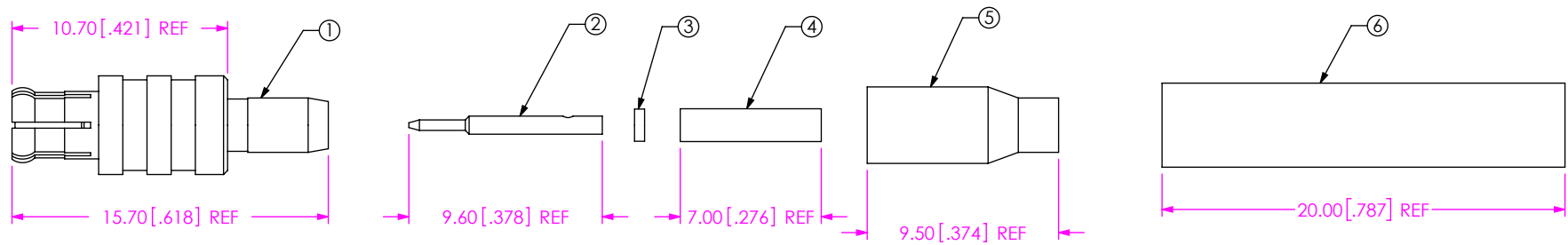
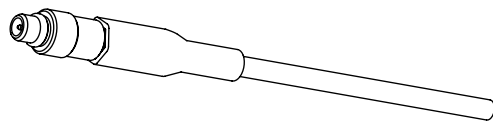
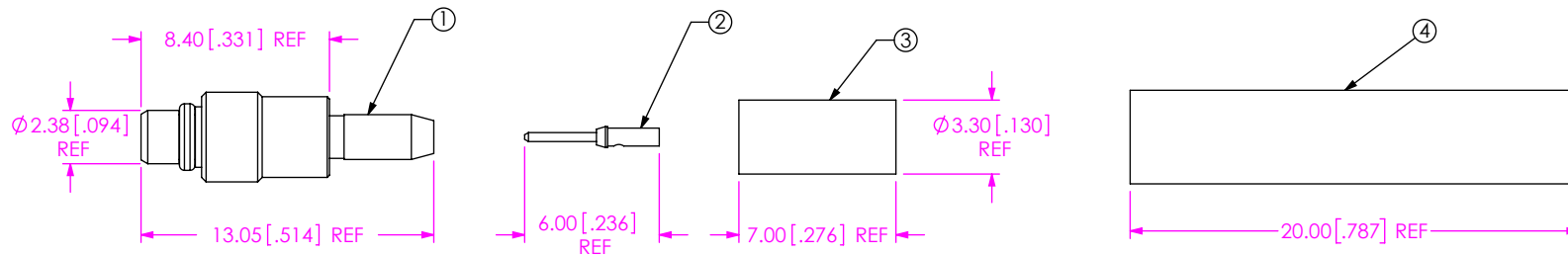

BOM		
ITEM	COMPONENT	-03SP1
1	SUB ASSEMBLY	SUB-MMCX-P-C-F-ST-CA2
2	PIN	MMCX-PIN-002-H
3	OUTER FERRULE	MCX-FER-005-F
4	HEAT SHRINK	HST-0.125-02-BLK

PROPRIETARY NOTE
 THIS DOCUMENT CONTAINS CONFIDENTIAL AND PROPRIETARY INFORMATION AND ALL DESIGN, MANUFACTURING, REPRODUCTION, USE, PATENT RIGHTS AND SALES RIGHTS ARE EXPRESSLY RESERVED BY SAMTEC, INC. THIS DOCUMENT SHALL NOT BE DISCLOSED, IN WHOLE OR PART, TO ANY UNAUTHORIZED PERSON OR ENTITY NOR REPRODUCED, TRANSFERRED OR INCORPORATED IN ANY OTHER PROJECT IN ANY MANNER WITHOUT THE EXPRESS WRITTEN CONSENT OF SAMTEC, INC.

DO NOT SCALE DRAWING

SHEET SCALE: 3:1



520 PARK EAST BLVD, NEW ALBANY, IN 47150
 PHONE: 812-944-6733 FAX: 812-948-5047
 e-Mail info@SAMTEC.com code 55322

DESCRIPTION: RG178 CABLE ASSEMBLY

DWG. NO. RF178-XXXXX-XXXXXX-XXXX

BY: TIM P. 5/6/2005 SHEET 6 OF 12

FIG 11
-03RP1 SHOWN

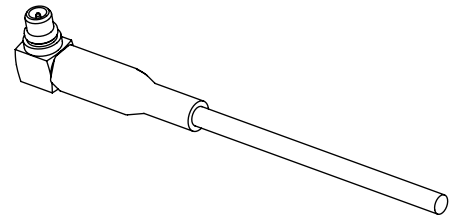
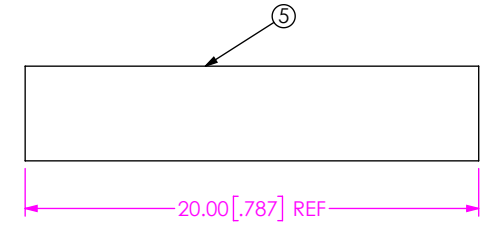
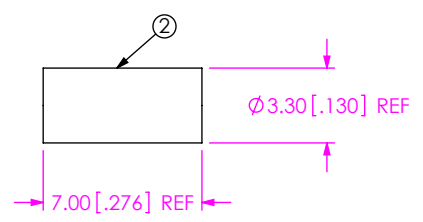
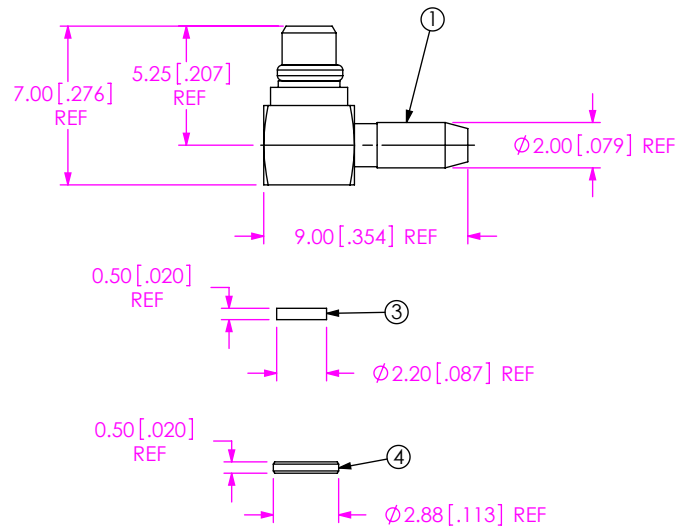

BOM		
ITEM	COMPONENT	-03RP1
1	SUB ASSEMBLY	SUB-MMCX-P-C-HF-RA-CA2
2	FERRULE	MCX-FER-005-F
3	INSULATOR	MMCX-INS-001
4	CAP	MMCX-CAP-001-F
5	HEAT SHRINK	HST-0.125-02-BLK

FIG 12
-04SPX SHOWN

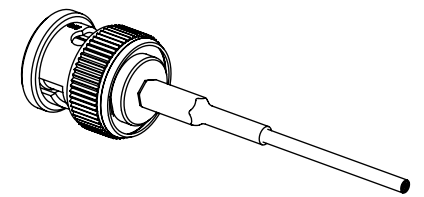
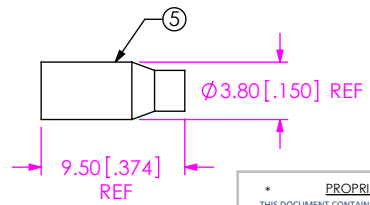
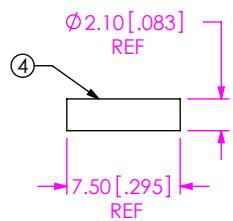
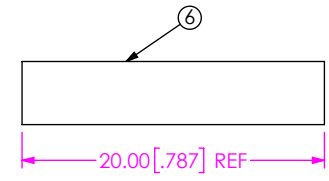
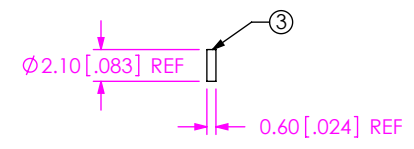
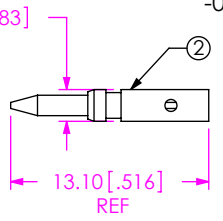
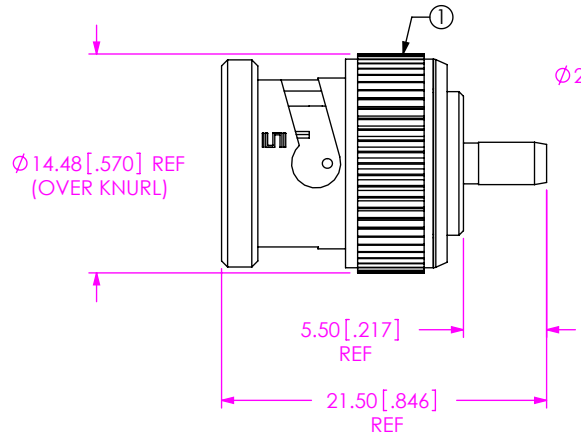

F:\DWG\MISC\MKTG\RF178-XXXXX-XXXXX-XXXX-MKT.SLDDRW

BOM			
ITEM	COMPONENT	-04SP2	-04SP3
1	SUB ASSEMBLY	SUB-BNC5-P-C-N-ST-CA2	
2	PIN	BNC5-P-C-H-ST-CA2-PIN	BNC5-P-C-G-ST-CA2-PIN
3	INSULATOR	BNC5-INS-002	
4	INNER FERRULE	MCX-FER-011-N	
5	FERRULE	MCX-FER-004-N	
6	HEAT SHRINK	HST-0.125-02-BLK	

PROPRIETARY NOTE
THIS DOCUMENT CONTAINS CONFIDENTIAL AND PROPRIETARY INFORMATION AND ALL DESIGN, MANUFACTURING, REPRODUCTION, USE, PATENT RIGHTS AND SALES RIGHTS ARE EXPRESSLY RESERVED BY SAMTEC, INC. THIS DOCUMENT SHALL NOT BE DISCLOSED, IN WHOLE OR PART, TO ANY UNAUTHORIZED PERSON OR ENTITY NOR REPRODUCED, TRANSFERRED OR INCORPORATED IN ANY OTHER PROJECT IN ANY MANNER WITHOUT THE EXPRESS WRITTEN CONSENT OF SAMTEC, INC.

DO NOT SCALE DRAWING

SHEET SCALE: 3:1



520 PARK EAST BLVD, NEW ALBANY, IN 47150
PHONE: 812-944-6733 FAX: 812-948-5047
e-Mail info@SAMTEC.com code 55322

DESCRIPTION: RG178 CABLE ASSEMBLY

DWG. NO. RF178-XXXXX-XXXXX-XXXX

BY: TIM P. 5/6/2005 SHEET 7 OF 12

FIG 13
-04BJ2 SHOWN

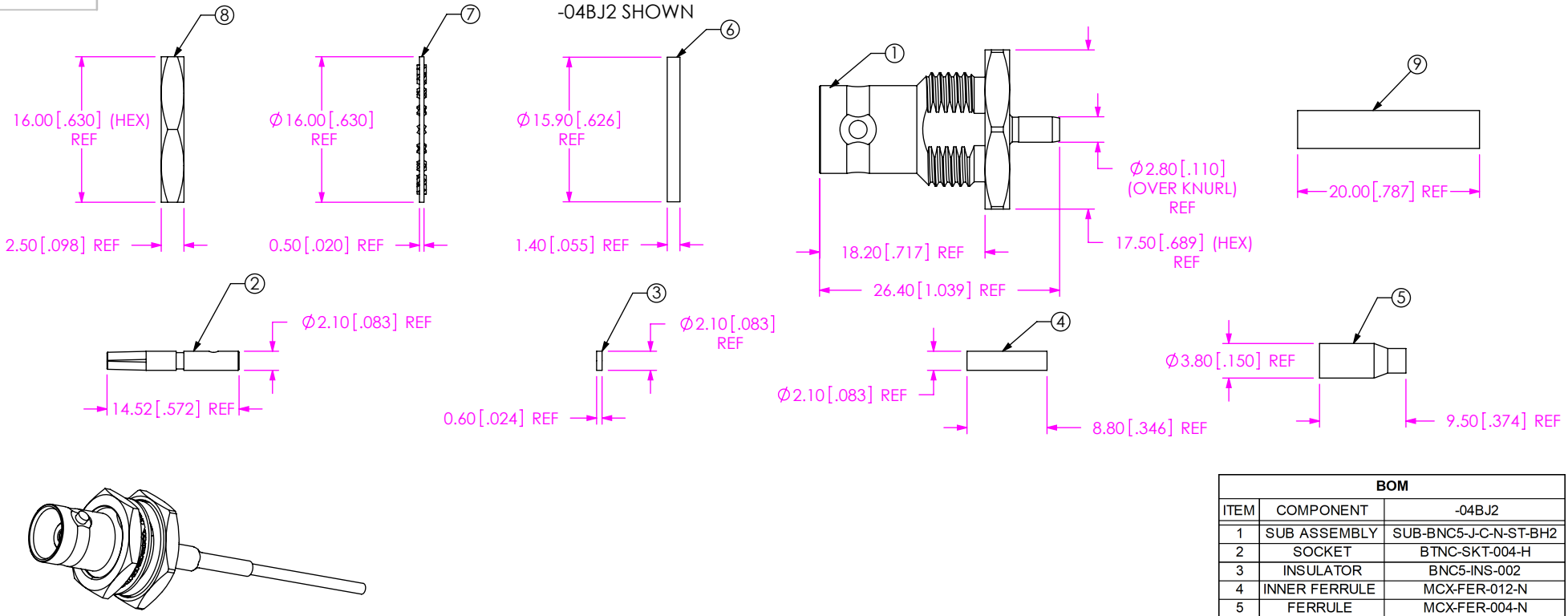

BOM		
ITEM	COMPONENT	-04BJ2
1	SUB ASSEMBLY	SUB-BNC5-J-C-N-ST-BH2
2	SOCKET	BTNC-SKT-004-H
3	INSULATOR	BNC5-INS-002
4	INNER FERRULE	MCX-FER-012-N
5	FERRULE	MCX-FER-004-N
6	GASKET	BTNC-GKT-001
7	LOCK WASHER	BTNC-LWAS-001-N
8	HEX NUT	BTNC-NUT-001-N
9	HEAT SHRINK	HST-0.125-02-BLK

PROPRIETARY NOTE
 THIS DOCUMENT CONTAINS CONFIDENTIAL AND PROPRIETARY INFORMATION AND ALL DESIGN, MANUFACTURING, REPRODUCTION, USE, PATENT RIGHTS AND SALES RIGHTS ARE EXPRESSLY RESERVED BY SAMTEC, INC. THIS DOCUMENT SHALL NOT BE DISCLOSED, IN WHOLE OR PART, TO ANY UNAUTHORIZED PERSON OR ENTITY NOR REPRODUCED, TRANSFERRED OR INCORPORATED IN ANY OTHER PROJECT IN ANY MANNER WITHOUT THE EXPRESS WRITTEN CONSENT OF SAMTEC, INC.

DO NOT SCALE DRAWING
 SHEET SCALE: 2:1



520 PARK EAST BLVD, NEW ALBANY, IN 47150
 PHONE: 812-944-6733 FAX: 812-948-5047
 e-Mail info@SAMTEC.com code 55322

DESCRIPTION: RG178 CABLE ASSEMBLY
 DWG. NO. RF178-XXXXX-XXXXXX-XXXX
 BY: TIM P. 5/6/2005 SHEET 8 OF 12

FIG 15
-05BJ3 SHOWN

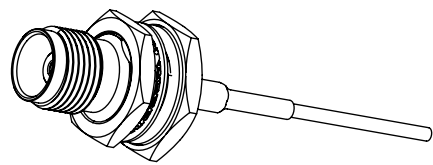
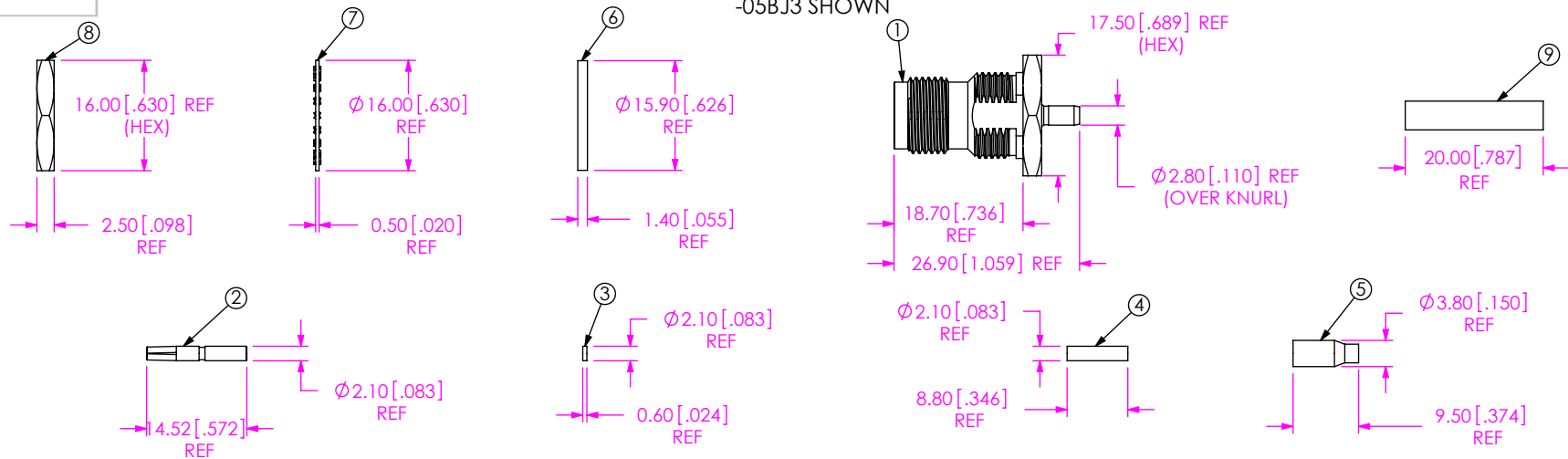

BOM		
ITEM	COMPONENT	-05BJ3
1	SUB ASSEMBLY	SUB-TNC-J-C-N-ST-BH2
2	SOCKET	BTNC-SKT-004-H
3	INSULATOR	BNC5-INS-002
4	INNER FERRULE	MCX-FER-012-N
5	FERRULE	MCX-FER-004-N
6	GASKET	BTNC-GKT-001
7	LOCK WASHER	BTNC-LWAS-001-N
8	HEX NUT	BTNC-NUT-001-N
9	HEAT SHRINK	HST-0.125-02-BLK

FIG 16
-06BJ2 SHOWN

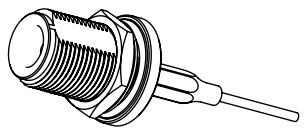
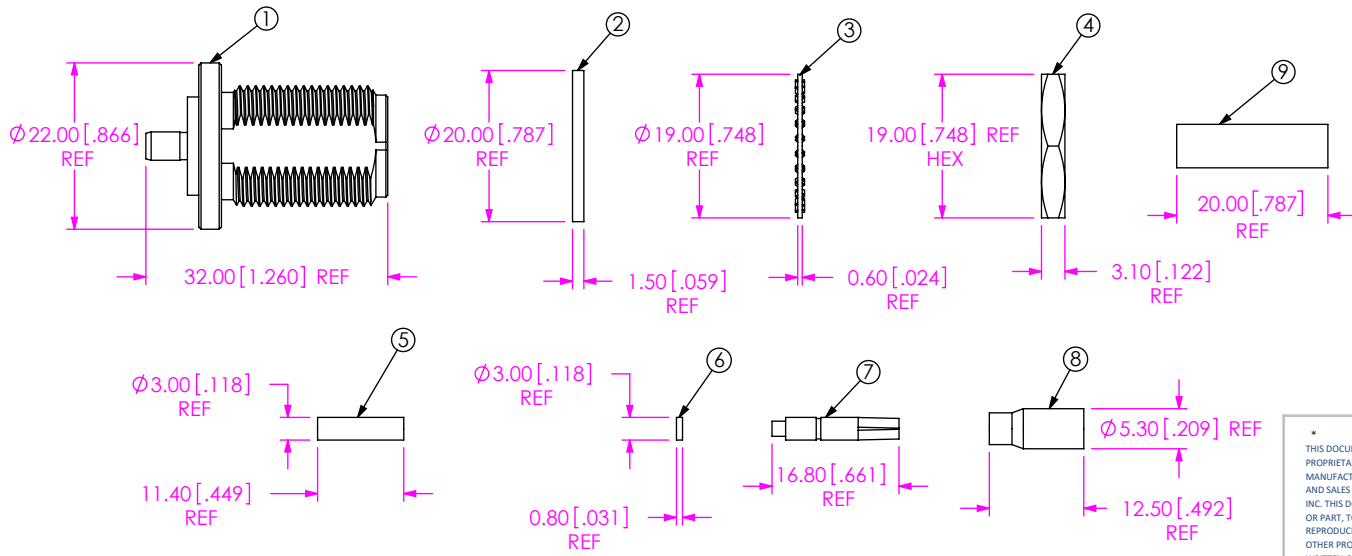

BOM		
ITEM	COMPONENT	-06BJ2
1	SUB ASSEMBLY	SUB-NTPE-J-C-N-ST-BH2
2	GASKET	NTPE-GKT-001
3	LOCK WASHER	NTPE-LWAS-001-N
4	HEX NUT	NTPE-NUT-001-N
5	INNER FERRULE	MCX-FER-013-N
6	INSULATOR	BNC5-INS-003
7	SOCKET	NTPE-J-C-H-ST-BH2-SKT
8	FERRULE	BNC-FER-002-N
9	HEAT SHRINK	HST-0.187-02-BLK

PROPRIETARY NOTE
THIS DOCUMENT CONTAINS CONFIDENTIAL AND PROPRIETARY INFORMATION AND ALL DESIGN, MANUFACTURING, REPRODUCTION, USE, PATENT RIGHTS AND SALES RIGHTS ARE EXPRESSLY RESERVED BY SAMTEC, INC. THIS DOCUMENT SHALL NOT BE DISCLOSED, IN WHOLE OR PART, TO ANY UNAUTHORIZED PERSON OR ENTITY NOR REPRODUCED, TRANSFERRED OR INCORPORATED IN ANY OTHER PROJECT IN ANY MANNER WITHOUT THE EXPRESS WRITTEN CONSENT OF SAMTEC, INC.

DO NOT SCALE DRAWING
SHEET SCALE: 1:1



520 PARK EAST BLVD. NEW ALBANY, IN 47150
PHONE: 812-944-6733 FAX: 812-948-5047
e-Mail info@SAMTEC.com code 55322

DESCRIPTION: RG178 CABLE ASSEMBLY
DWG. NO. RF178-XXXXX-XXXXXX-XXXX
BY: TIM P. 5/6/2005 SHEET 9 OF 12

FIG 17
-07BJX SHOWN

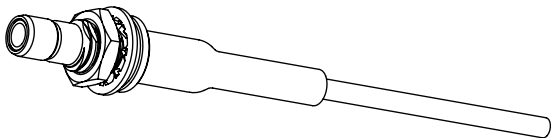
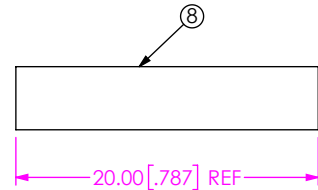
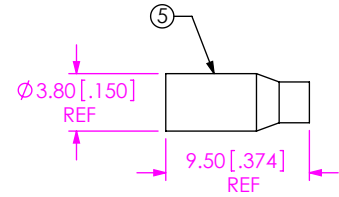
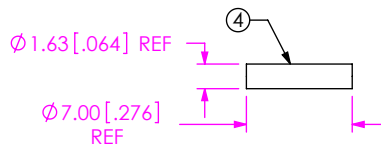
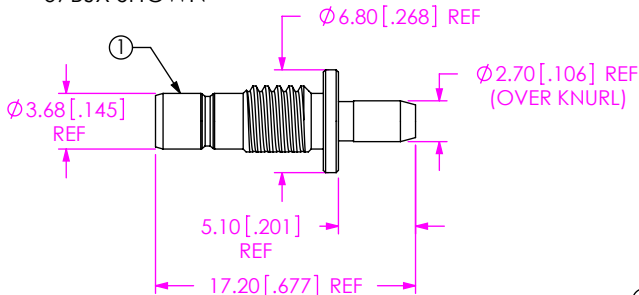
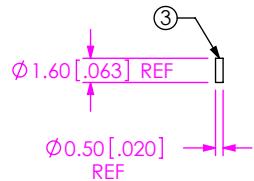
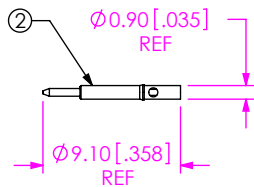
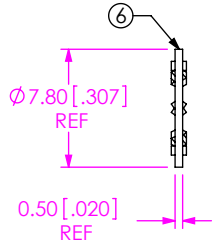
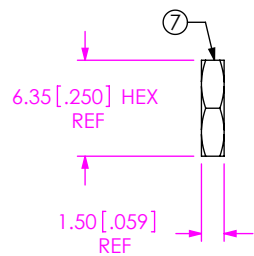

BOM			
ITEM	COMPONENT	-07BJ2	-07BJ4
1	SUB ASSEMBLY	SUB-SMB5-J-C-F-ST-CA2	SUB-SMB5-J-C-F-ST-CA2
2	PIN	SMB5-PIN-003-H	SMB5-PIN-003-G
3	INSULATOR	MCX-INS-002	
4	INNER FERRULE	MCX-FER-003-F	MCX-FER-003-F
5	FERRULE	MCX-FER-004-F	MCX-FER-004-F
6	LOCK WASHER	SMB-LWAS-001-F	SMB-LWAS-001-F
7	HEX NUT	SMB5-NUT-001-F	SMB5-NUT-001-F
8	HEAT SHRINK	HST-0.125-02-BLK	

F:\DWG\MISC\MKTG\RF178-XXXX-XXXX-XXXX-MKT.SLDDRW

PROPRIETARY NOTE
 THIS DOCUMENT CONTAINS CONFIDENTIAL AND PROPRIETARY INFORMATION AND ALL DESIGN, MANUFACTURING, REPRODUCTION, USE, PATENT RIGHTS AND SALES RIGHTS ARE EXPRESSLY RESERVED BY SAMTEC, INC. THIS DOCUMENT SHALL NOT BE DISCLOSED, IN WHOLE OR PART, TO ANY UNAUTHORIZED PERSON OR ENTITY NOR REPRODUCED, TRANSFERRED OR INCORPORATED IN ANY OTHER PROJECT IN ANY MANNER WITHOUT THE EXPRESS WRITTEN CONSENT OF SAMTEC, INC.

DO NOT SCALE DRAWING

SHEET SCALE: 3:1



520 PARK EAST BLVD, NEW ALBANY, IN 47150
 PHONE: 812-944-6733 FAX: 812-948-5047
 e-Mail info@SAMTEC.com code 55322

DESCRIPTION: RG178 CABLE ASSEMBLY

DWG. NO. RF178-XXXX-XXXX-XXXX

BY: TIM P. 5/6/2005 SHEET 10 OF 12

IN-PROCESS 1
CUT CABLE TO LENGTH

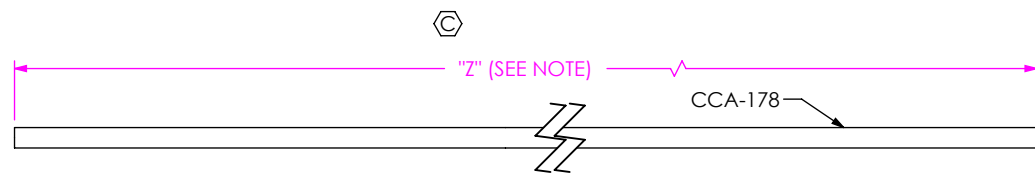

NOTE: "Z" = 2*OAL-2*"Y"(END 1) (FOR -SING OR -XXXXX OPTIONS)
 "Z" = OAL-"Y"(END 1)-"Y"(END 2) (FOR DOUBLE ENDED OPTIONS)

IN-PROCESS 2
STRIP AND TIN INNER CONDUCTOR

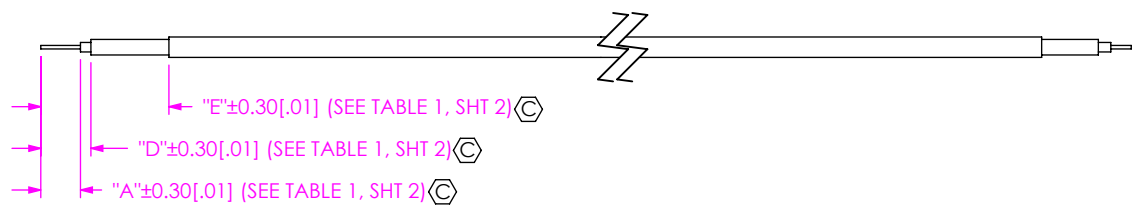

STRAIGHT

IN-PROCESS 3
ADD HEAT SHRINK TUBE AND OUTER FERRULE, INNER FERRULE AND WASHER IF APPLICABLE, SOLDER SIGNAL PIN

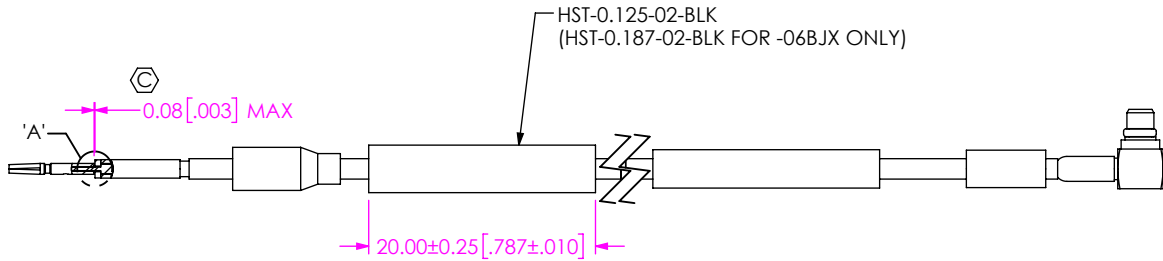

RIGHT ANGLE

IN-PROCESS 3
ADD HEAT SHRINK TUBE, FERRULE, FLARE SHIELD AND SUB ASSEMBLY (SEE NOTE 6)

IN-PROCESS 4
FLARE SHIELD AND ADD SUB ASSEMBLY (SEE NOTE 6)

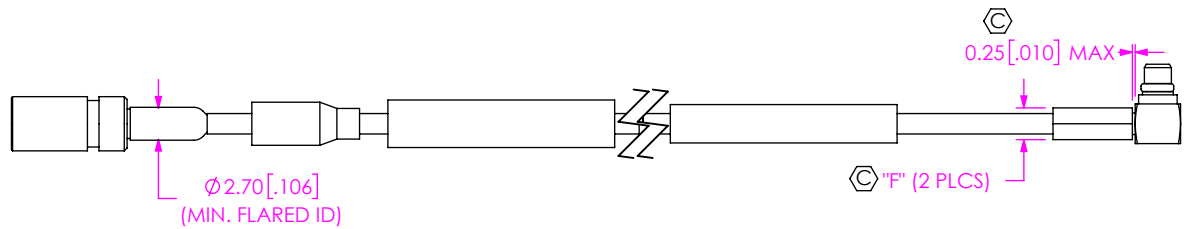

IN-PROCESS 4
CRIMP FERRULE

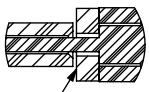

INSULATOR TO BE FLUSH WITH CABLE DIELECTRIC

DETAIL 'A'
SCALE 6 : 1

F:\DWG\MISC\MKTG\RF178-XXXX-XXXX-XXXX-MKT.SLDDRW

PROPRIETARY NOTE
 THIS DOCUMENT CONTAINS CONFIDENTIAL AND PROPRIETARY INFORMATION AND ALL DESIGN, MANUFACTURING, REPRODUCTION, USE, PATENT RIGHTS AND SALES RIGHTS ARE EXPRESSLY RESERVED BY SAMTEC, INC. THIS DOCUMENT SHALL NOT BE DISCLOSED, IN WHOLE OR PART, TO ANY UNAUTHORIZED PERSON OR ENTITY NOR REPRODUCED, TRANSFERRED OR INCORPORATED IN ANY OTHER PROJECT IN ANY MANNER WITHOUT THE EXPRESS WRITTEN CONSENT OF SAMTEC, INC.
 DO NOT SCALE DRAWING
 SHEET SCALE: 3:2

samtec	
520 PARK EAST BLVD, NEW ALBANY, IN 47150 PHONE: 812-944-6733 FAX: 812-948-5047 e-Mail info@SAMTEC.com code 55322	
DESCRIPTION: RG178 CABLE ASSEMBLY	
DWG. NO. RF178-XXXX-XXXX-XXXX	
BY: TIM P.	5/6/2005 SHEET 11 OF 12

IN-PROCESS 5
CRIMP FERRULE

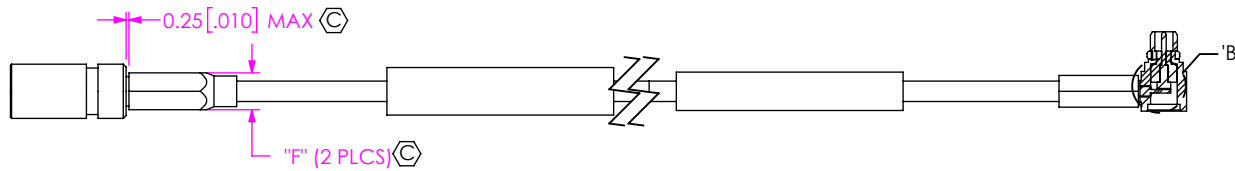

IN-PROCESS 5
SOLDER SIGNAL PIN

IN-PROCESS 6
ACTIVTE HEAT SHRINK

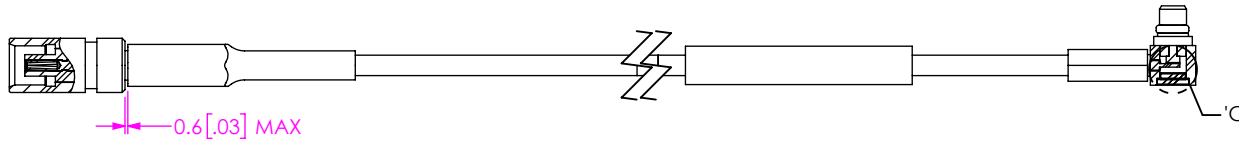

IN-PROCESS 6
INSERT INSULATOR & CAP

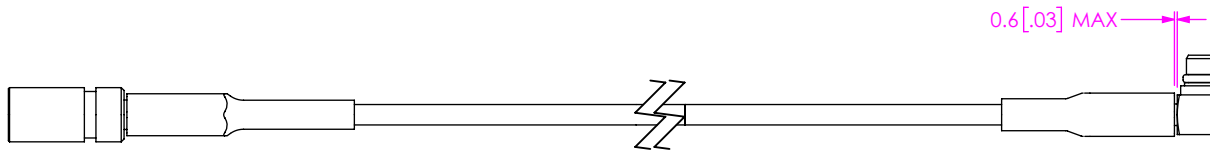

IN-PROCESS 7
ACTIVATE HEAT SHRINK

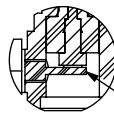

CABLE CENTER CONDUCTOR
SHOULD NOT PROTRUDE
OUTSIDE CONTACT CUP

DETAIL 'B'
SCALE 3 : 1

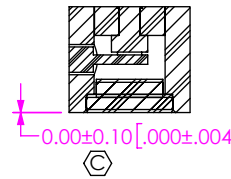

$0.00 \pm 0.10 [0.000 \pm 0.004]$

DETAIL 'C'
SCALE 4 : 1

F:\DWG\MISC\MKTG\RF178-XXXX-XXXX-XXXX-MKT.SLDRW

PROPRIETARY NOTE

THIS DOCUMENT CONTAINS CONFIDENTIAL AND PROPRIETARY INFORMATION AND ALL DESIGN, MANUFACTURING, REPRODUCTION, USE, PATENT RIGHTS AND SALES RIGHTS ARE EXPRESSLY RESERVED BY SAMTEC, INC. THIS DOCUMENT SHALL NOT BE DISCLOSED, IN WHOLE OR PART, TO ANY UNAUTHORIZED PERSON OR ENTITY NOR REPRODUCED, TRANSFERRED OR INCORPORATED IN ANY OTHER PROJECT IN ANY MANNER WITHOUT THE EXPRESS WRITTEN CONSENT OF SAMTEC, INC.

DO NOT SCALE DRAWING

SHEET SCALE: 3:2



520 PARK EAST BLVD, NEW ALBANY, IN 47150
PHONE: 812-944-6733 FAX: 812-948-5047
e-Mail info@SAMTEC.com code 55322

DESCRIPTION: RG178 CABLE ASSEMBLY

DWG. NO. RF178-XXXX-XXXX-XXXX

BY: TIM P. 5/6/2005 SHEET 12 OF 12