

APPROVED: _____

DATE: _____ TITLE: _____

Rev	AWO #	Description	Date	Appr
-		RELEASED	10/7/22	
A		UPDATE SPEC.	9/8/23	LH/RC

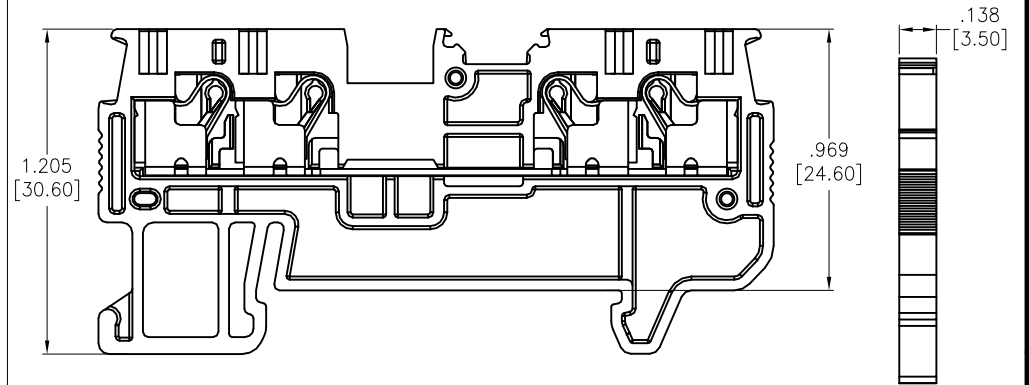
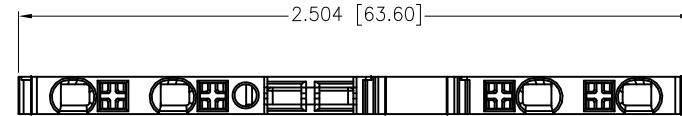
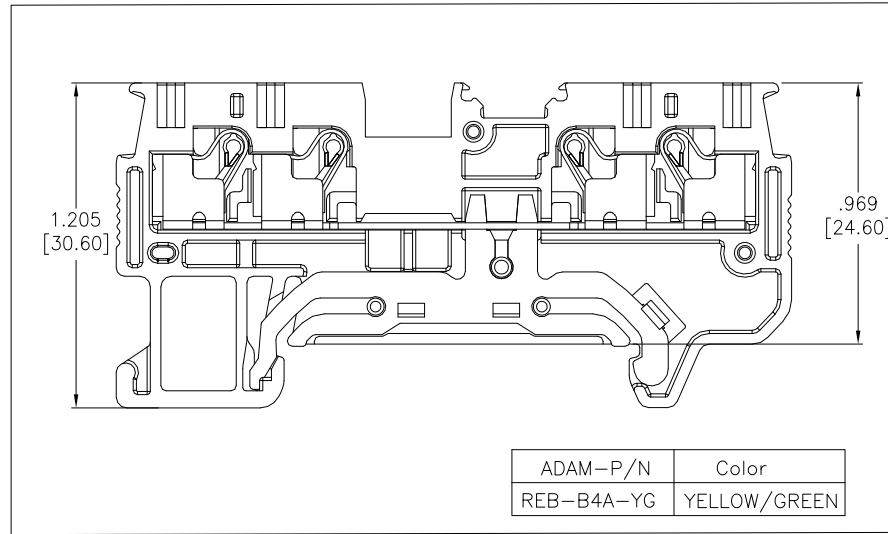

SPECIFICATIONS:

Material:
 Insulator: PA66, rated UL 94V-0
 Insulator Color: See Chart
 Contacts: Copper Alloy, Tin Plated
 Electrical:
 Voltage rating: 300 VAC
 Current rating: 15 Amp
 Dielectric withstanding voltage: 1600 VAC for 1 minute
 Mechanical:
 Recommended Wire Size:
 Solid: 24-16 Awg (0.2-1.5mm²)
 Stranded: 24-16 Awg (0.2-15mm²)
 Stripping Length: .315"~.394" (8-10mm)
 Temperature Rating:
 Operating temperature: -40°C to +105°C
 Environmental:
 Lead free, RoHS compliant.



RECOMMENDED RAIL SIZE
35.0mm X 7.5mm

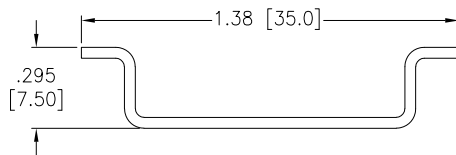

REB-B 4 A -XX

Color
OR=Orange
BU=Blue
GY=Gray
YG=Yellow/Green

ADAM-P/N	Color
REB-B4A-OR	ORANGE
REB-B4A-BU	BLUE
REB-B4A-GY	GRAY
REB-B4A-YG	YELLOW/GREEN

UNLESS OTHERWISE SPECIFIED ALL DIMENSIONS ARE INCHES [MM]. TOLERANCES: EXCEPT AS NOTED

INCHES		HOLES	
.X	± .10	∅X	±.10
.XX	± .020	∅XX	±.015
.XXX	± .015	∅XXX	±.010

DRAWN	JJ	10/7/22
CHECKED	RC	10/7/22
APPROVED		

THIS DRAWING CONTAINS INFORMATION THAT IS PROPRIETARY AND SHOULD NOT BE USED WITHOUT PRIOR WRITTEN PERMISSION FROM ADAM TECH

ADAM TECH 909 Rahway Avenue,
 Union, NJ 07083
 Phone: 908-687-5000
 Fax: 908-687-5710

TITLE		REV. A
DIN RAIL TERMINAL BLOCKS, GUV 4 HOLE, 1.5 FLEXIBLE		
SIZE X	PART NO. REB-B4A-XX	
REF: S00067C	SCALE: NTS	SHEET 1 OF 1