

APPROVED: _____

DATE: _____ TITLE: _____

Rev	AWO #	Description	Date	Appr
-		RELEASED	10/7/22	
A		UPDATE SPEC.	9/8/23	LH/RC

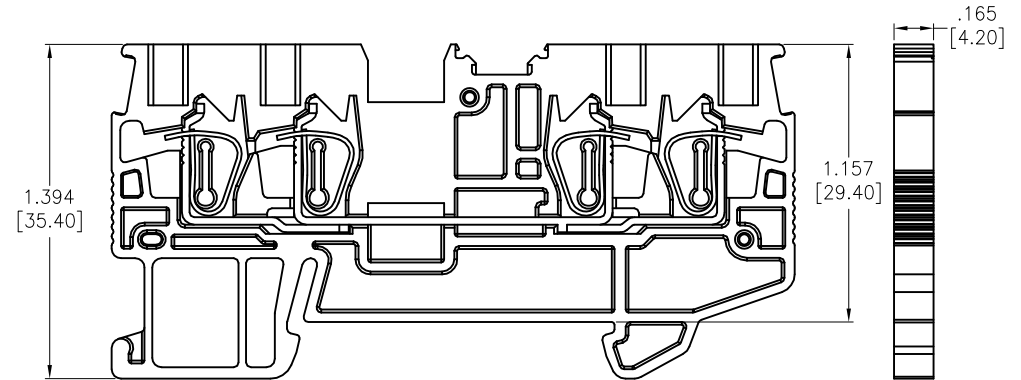
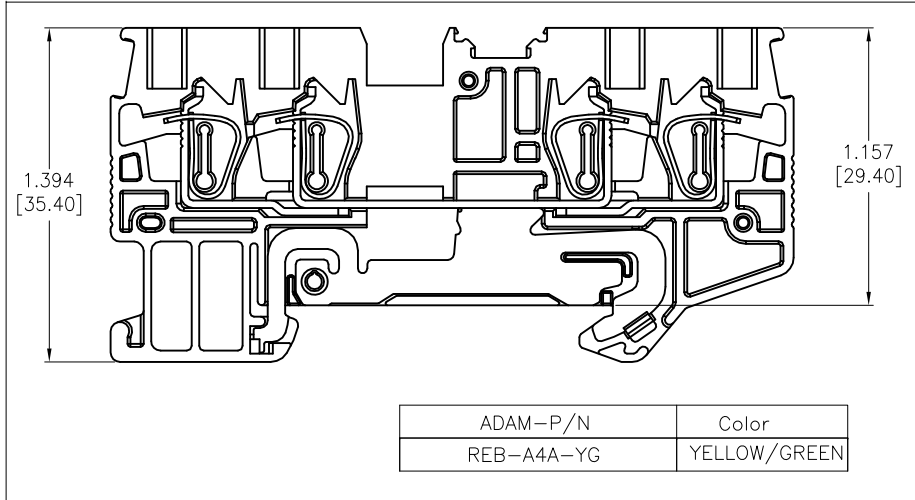
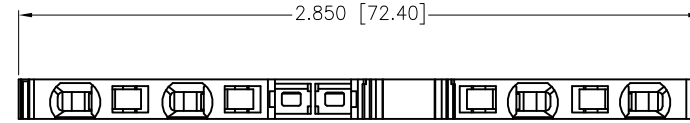

SPECIFICATIONS:

Material:

Insulator: PA66, rated UL 94V-0

Insulator color: See chart

Contacts: Copper Alloy, Tin Plated

Electrical:

Voltage rating: 300V

Current rating: 15A

Dielectric withstanding voltage: 1,600 VAC for 1 minute

Mechanical:

Recommended Wire Size:

Solid: 24-16AWG (0.2-1.5mm²)

Stranded: 24-16AWG (0.2-1.5mm²)

Stripping Length: .315"-.394" (8-10mm)

Temperature Rating:

Operating temperature: -40°C to +105°C

Environmental:

Lead free, RoHS compliant. 

RECOMMENDED RAIL SIZE
35.0mm X 7.5mm

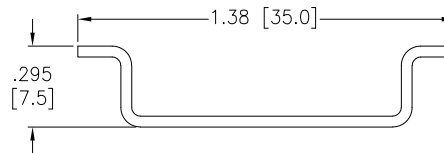

ADAM-P/N	Color
REB-A4A-BU	BLUE
REB-A4A-GY	GRAY
REB-A4A-YG	YELLOW/GREEN

ADAM-P/N	Color
REB-A4A-BU	BLUE
REB-A4A-GY	GRAY
REB-A4A-YG	YELLOW/GREEN

UNLESS OTHERWISE SPECIFIED ALL DIMENSIONS ARE INCHES [MM]. TOLERANCES: EXCEPT AS NOTED

INCHES		HOLES	
.X	± .10	∅X	±.10
.XX	± .020	∅XX	±.015
.XXX	± .015	∅XXX	±.010



909 Rahway Avenue,
Union, NJ 07083
Phone: 908-687-5000
Fax: 908-687-5710

DRAWN	WX	10/7/22
CHECKED	RC	10/7/22
APPROVED		

TITLE
DIN RAIL TERMINAL BLOCKS, GUS, 4HOLE, 1.5 FLEXIBLE

THIS DRAWING CONTAINS INFORMATION THAT IS PROPRIETARY AND SHOULD NOT BE USED WITHOUT PRIOR WRITTEN PERMISSION FROM ADAM TECH

SIZE X	PART NO. REB-A4A-XX	REV. A
REF: S00067C	SCALE: NTS	SHEET 1 OF 1