

SERIES: PS07 | **DESCRIPTION:** PRESSURE SENSOR**FEATURES**

- temperature compensated
- multiple pressure range options
- absolute and sealed gauge pressure options
- stainless steel housing
- o-ring seal

**SPECIFICATIONS**

parameter	conditions/description	min	typ	max	units
pressure range	see Pressure Specifications for more details	0		100	MPa
pressure reference	absolute pressure, sealed gauge pressure				
excitation			1.5	2.5	mA
input impedance		2		5	k Ω
insulation resistance	at 250 Vdc	200			M Ω
response time	up to 90%FS			1	ms
vibration	20 G (20~5,000 Hz)				
shock	100 G for 10 ms				
compensated temperature	≤35 kPa models	0		60	°C
	all other models	-10		70	°C
operating temperature		-40		125	°C
storage temperature		-40		125	°C
life			1,000,000		cycles
RoHS	yes				

MECHANICAL

parameter	conditions/description	min	typ	max	units
measured medium	all 316L compatible liquids and gases				
housing/diaphragm	stainless steel 316L				
dimensions	Ø19 x 14				mm
weight			80		g

BASIC PARAMETERS

parameter	conditions/description	min	typ	max	units
nonlinearity ¹		-0.3	±0.2	0.3	%FS
hysteresis		-0.05	±0.03	0.05	%FS
repeatability		-0.05	±0.03	0.05	%FS
zero output		-2	±0.2	2	mV
full scale span output	≤35 kPa models	40	90	150	mV
	all other models	60	90	150	mV
zero temperature coefficient ²	≤10 kPa models	-2	±1.5	2	%FS
	all other models	-1.5	±0.75	1.5	%FS
span temperature coefficient ²		-1.5	±0.75	1.5	%FS
thermal hysteresis ³		-0.075	±0.05	0.075	%FS
long term stability		-0.3	±0.2	0.3	%FS/year

Note:

1. Calculated according to best fit straight line (BFSL) least square method.
2. In the compensated temperature range, refer to 30°C.
3. After passing high and low temperature, return to the reference temperature.

PRESSURE SPECIFICATIONS

pressure range	pressure reference ⁴	overload pressure	burst pressure
0~100 kPa	A	200%FS	500%FS
0~250 kPa	A	200%FS	500%FS
0~400 kPa	A	200%FS	500%FS
0~1.0 MPa	A	200%FS	500%FS
0~1.6 MPa	A, S	200%FS	500%FS
0~2.5 MPa	S	200%FS	500%FS
0~4.0 MPa	S	200%FS	400%FS
0~6.0 MPa	S	200%FS	400%FS
0~10 MPa	S	200%FS	400%FS
0~16 MPa	S	200%FS	400%FS
0~25 MPa	S	150%FS	400%FS
0~40 MPa	S	150%FS	300%FS
0~60 MPa	S	150%FS	300%FS
0~100 MPa	S	150%FS	300%FS

Note: 4. A=absolute pressure (vacuum is zero); S=sealed gauge pressure (calibrated atmospheric pressure is zero).

PART NUMBER KEY

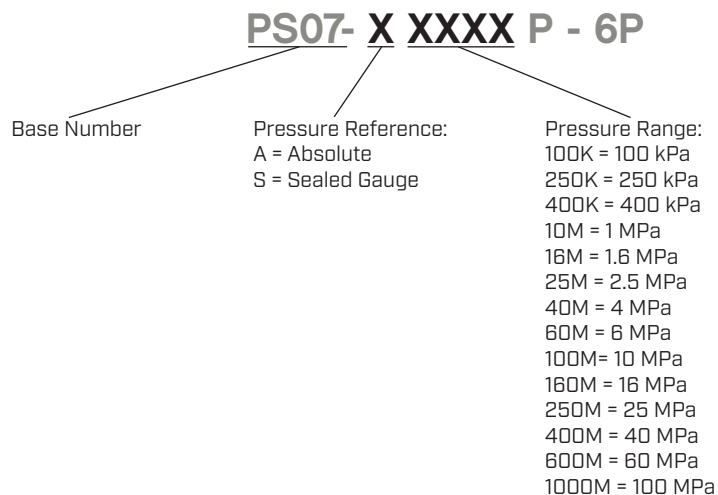

MECHANICAL DRAWING

units: mm
tolerance: ±0.1 mm
unless otherwise noted

ITEM	DESCRIPTION	MATERIAL	PLATING/COLOR
A	housing	SS 316L	
B	diaphragm	SS 316L	
C	oil filling	silicon oil	
D	o-ring	NBR [≤4 Mpa models]	black
		fluorine rubber [>4 Mpa models]	brown
E	pins	KOVAR	gold

PIN CONNECTIONS	
Pin #	Function
1	NC
2	+OUT
3	+IN
4	-OUT
5	-IN
6	NC

Sealed Gauge Pressure or Absolute Pressure <16 MPa

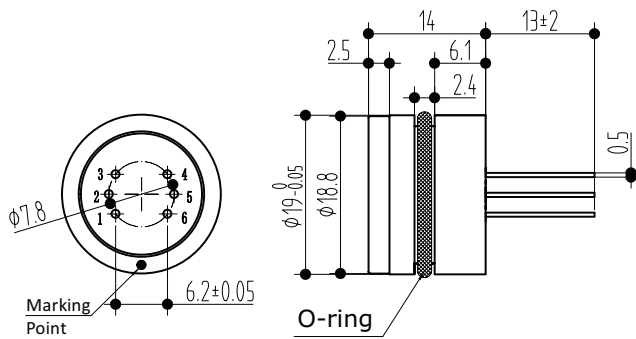

Sealed Gauge Pressure ≥16 MPa

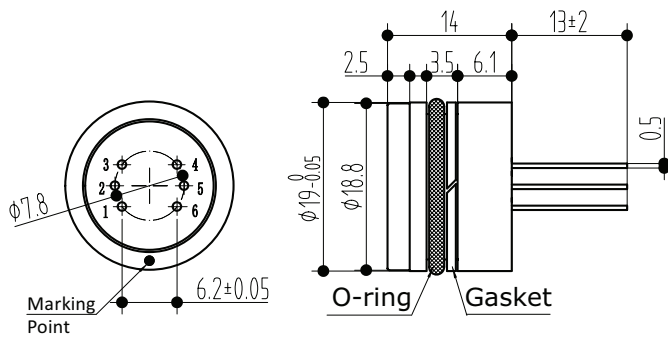

INTERFACE DIAGRAM

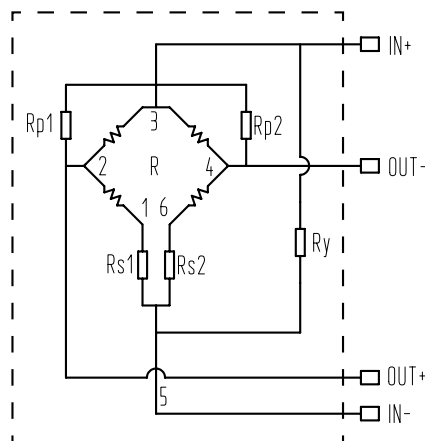

USAGE CONSIDERATIONS

1. Do not touch the diaphragm with hard objects, which may cause damage to the diaphragm.
2. Strictly follow the wiring method, otherwise it may cause product damage or other potential faults.
3. Misuse of the product may cause danger or personal injury.
4. Pressure range can be selected higher or lower than actual conditions, but should be within $\pm 30\%FS$.
5. Pressure reference consists of gauge pressure, absolute pressure, and sealed gauge pressure.
 - a. Gauge pressure is based on the current atmospheric pressure. Generally, it refers to the measurement of pressure which is greater than the current atmospheric pressure. Negative pressure is a special case of gauge pressure. It refers that there is such working condition that the pressure of work site is lower than the current atmospheric pressure.
 - b. Absolute pressure is based on vacuum.
 - c. Sealed gauge pressure uses absolute pressure die for gauge pressure product based on the atmospheric pressure of production site.
6. Confirm the maximum overload of the applied system, which should be less than the overload protection limit of the sensor, otherwise it will affect the product life or even damage the product.
7. The material and process for manufacturing negative pressure sensors are different from those of positive pressure sensors. So, gauge pressure sensors cannot be used as substitute of negative pressure sensors.

REVISION HISTORY

rev.	description	date
1.0	initial release	12/09/2021
1.01	added pin detail to drawing	06/14/2022
1.02	logo, datasheet style update	08/05/2022

The revision history provided is for informational purposes only and is believed to be accurate.



CUI Devices offers a one (1) year limited warranty. Complete warranty information is listed on our website.

CUI Devices reserves the right to make changes to the product at any time without notice. Information provided by CUI Devices is believed to be accurate and reliable. However, no responsibility is assumed by CUI Devices for its use, nor for any infringements of patents or other rights of third parties which may result from its use.

CUI Devices products are not authorized or warranted for use as critical components in equipment that requires an extremely high level of reliability. A critical component is any component of a life support device or system whose failure to perform can be reasonably expected to cause the failure of the life support device or system, or to affect its safety or effectiveness.

cuidevices.com