



MEAS | MEAS FS

TE Internal #: FS1901-0000-0500-G

TE Internal Description: 500 GRAM FORCE 20MV/V FORCE LOAD

CELL

FORCE LOAD CELL - 20MV/V

[View on TE.com >](#)

Sensors > Force Sensors > Force Sensor Elements > FORCE LOAD CELL - 20MV/V



Force Sensor Element Sensor Type: OEM Compression Load Cells

Full Scale Range: 5 Nm

Operating Temperature Range: 0 – 40 °C [32 – 104 °F]

Output Signal: 20 mV/V

Zero Shift in CTR: ±.05 % of FS

[All FORCE LOAD CELL - 20MV/V \(4\)](#)

Features

Product Type Features

Force Sensor Element Sensor Type	OEM Compression Load Cells
----------------------------------	----------------------------

Electrical Characteristics

Supply Voltage	5 VDC
----------------	-------

Full Scale Range	5 Nm
------------------	------

Signal Characteristics

Output Signal	20 mV/V
---------------	---------

Usage Conditions

Operating Temperature Range	0 – 40 °C[32 – 104 °F]
-----------------------------	------------------------

Other

Accuracy	±1 % of FS
----------	------------

Force Direction	Compression
-----------------	-------------

Zero Shift in CTR	±.05 % of FS
-------------------	--------------

Sensitivity Shift	±.05 % of FS
-------------------	--------------

Product Compliance

[For compliance documentation, visit the product page on TE.com>](#)



EU RoHS Directive 2011/65/EU	Compliant with Exemptions
EU ELV Directive 2000/53/EC	Compliant with Exemptions
China RoHS 2 Directive MIIT Order No 32, 2016	Restricted Materials Above Threshold
EU REACH Regulation (EC) No. 1907/2006	<p>Current ECHA Candidate List: JUNE 2023 (235) Candidate List Declared Against: JUNE 2023 (235) SVHC > Threshold: Decamethylcyclopentasiloxane (D5) (.12% in Adhesive) Dodecamethylcyclohexasiloxane (D6) (.26% in Adhesive)</p> <p>Article Safe Usage Statements: Wash thoroughly after handling. Recycle if possible and dispose of the article by following all applicable governmental regulations relevant to your geographic location.</p>
Halogen Content	Not Low Halogen - contains Br or Cl > 900 ppm.
Solder Process Capability	Not reviewed for solder process capability

Product Compliance Disclaimer

This information is provided based on reasonable inquiry of our suppliers and represents our current actual knowledge based on the information they provided. This information is subject to change. The part numbers that TE has identified as EU RoHS compliant have a maximum concentration of 0.1% by weight in homogenous materials for lead, hexavalent chromium, mercury, PBB, PBDE, DBP, BBP, DEHP, DIBP, and 0.01% for cadmium, or qualify for an exemption to these limits as defined in the Annexes of Directive 2011/65/EU (RoHS2). Finished electrical and electronic equipment products will be CE marked as required by Directive 2011/65/EU. Components may not be CE marked. Additionally, the part numbers that TE has identified as EU ELV compliant have a maximum concentration of 0.1% by weight in homogenous materials for lead, hexavalent chromium, and mercury, and 0.01% for cadmium, or qualify for an exemption to these limits as defined in the Annexes of Directive 2000/53/EC (ELV). Regarding the REACH Regulation, the information TE provides on SVHC in articles for this part number is based on the latest European Chemicals Agency (ECHA) 'Guidance on requirements for substances in articles' posted at this URL: <https://echa.europa.eu/guidance-documents/guidance-on-reach>

Compatible Parts



Also in the Series | **MEAS FS**



Flow Switch(8)



Force Sensor Elements(18)

Customers Also Bought



TE Part #3-1879073-5
THS10 150R 5%



TE Part #2213934-2
SMT TB PERP PLUG, 5.0MM, 2 POS



TE Part #20009605-20
FX29K0-100A-0010-L



TE Part #5-1825137-0
A107SYCB04



TE Part #5-1879501-9
CRGH2512 5% 270R 2W

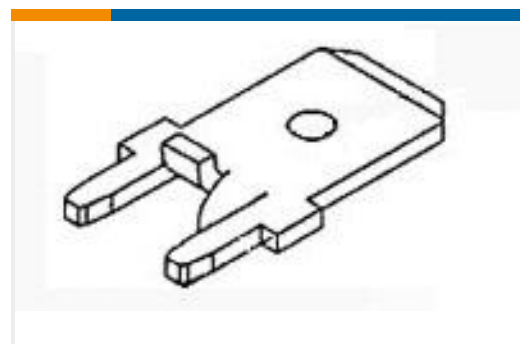

TE Part #63862-1
250 FASTON TAB TPBR



TE Part #20000980-00
MS5840-02BA21 LP T&R PRESS SEN



TE Part #7-2176363-4
RQ 0402 2K49 0.1% 10PPM 5K RL

Documents

CAD Files

3D PDF

3D

Customer View Model

[ENG_CVM_CVM_FS1901-0000-0500-G_A.2d_dxf.zip](#)

English

Customer View Model

[ENG_CVM_CVM_FS1901-0000-0500-G_A.3d_igs.zip](#)

English

Customer View Model

[ENG_CVM_CVM_FS1901-0000-0500-G_A.3d_stp.zip](#)

English

By downloading the CAD file I accept and agree to the [Terms and Conditions](#) of use.

Datasheets & Catalog Pages

FS19

English

