



AMP

TE Internal #: 880584-1

Board-to-Board Jumpers & Shunts, Novo, Closed Top, 2 Position, .1 in [2.54 mm] Centerline, Signal, -40 – 185 °F [-40 – 85 °C]

[View on TE.com >](#)

Connectors > PCB Connectors > Board-to-Board Connectors > Board-to-Board Jumpers & Shunts



Shunt Type: **Novo**

Shunt Style: **Closed Top**

Connector System: **Board-to-Board**

Number of Positions: **2**

Centerline (Pitch): **2.54 mm [.1 in]**

Features

Product Type Features

Connector System	Board-to-Board
Connector & Contact Terminates To	Printed Circuit Board

Configuration Features

Number of Positions	2
---------------------	---

Electrical Characteristics

Termination Resistance	15 mΩ
Insulation Resistance	5000 MΩ

Body Features

Handle	With
Primary Product Color	Black

Contact Features

Contact Mating Area Plating Material Thickness	.381 μm[15 μin]
Contact Mating Area Plating Material	Gold
Contact Base Material	Phosphor Bronze
Shunt Type	Novo
Shunt Style	Closed Top
Contact Current Rating (Max)	3 A

Mechanical Attachment

--	--



Connector Mounting Type	Board Mount
-------------------------	-------------

Housing Features

Housing Material	Thermoplastic
Centerline (Pitch)	2.54 mm[.1 in]

Dimensions

Product Height	14 mm[.551 in]
----------------	----------------

Usage Conditions

Operating Temperature Range	-40 – 85 °C[-40 – 185 °F]
-----------------------------	---------------------------

Operation/Application

Circuit Application	Signal
---------------------	--------

Industry Standards

UL Flammability Rating	UL 94V-0
------------------------	----------

Packaging Features

Jumper & Shunt Packaging	Loose Piece
Packaging Quantity	1000
Packaging Method	Loose Piece

Product Compliance

[For compliance documentation, visit the product page on TE.com>](#)

EU RoHS Directive 2011/65/EU	Compliant
EU ELV Directive 2000/53/EC	Compliant
China RoHS 2 Directive MIIT Order No 32, 2016	No Restricted Materials Above Threshold
EU REACH Regulation (EC) No. 1907/2006	Current ECHA Candidate List: JUNE 2023 (235) Candidate List Declared Against: JUNE 2023 (235) Does not contain REACH SVHC
Halogen Content	Low Halogen - Br, Cl, F, I < 900 ppm per homogenous material. Also BFR/CFR/PVC Free
Solder Process Capability	Not applicable for solder process capability

Product Compliance Disclaimer

This information is provided based on reasonable inquiry of our suppliers and represents our current actual knowledge based on the information they provided. This information is subject to change. The part numbers that TE has identified as EU RoHS compliant have a maximum concentration of 0.1% by weight in homogenous materials for lead, hexavalent

chromium, mercury, PBB, PBDE, DBP, BBP, DEHP, DIBP, and 0.01% for cadmium, or qualify for an exemption to these limits as defined in the Annexes of Directive 2011/65/EU (RoHS2). Finished electrical and electronic equipment products will be CE marked as required by Directive 2011/65/EU. Components may not be CE marked. Additionally, the part numbers that TE has identified as EU ELV compliant have a maximum concentration of 0.1% by weight in homogenous materials for lead, hexavalent chromium, and mercury, and 0.01% for cadmium, or qualify for an exemption to these limits as defined in the Annexes of Directive 2000/53/EC (ELV). Regarding the REACH Regulation, the information TE provides on SVHC in articles for this part number is based on the latest European Chemicals Agency (ECHA) 'Guidance on requirements for substances in articles' posted at this URL: <https://echa.europa.eu/guidance-documents/guidance-on-reach>

Compatible Parts



TE Part # 5-146280-2
02 MODII HDR SRST B/A .100CL



TE Part # 5-146276-2
02 MODII HDR SRST B/A .100CL



TE Part # 5-146284-2
02 MODII HDR SRST B/A .100CL

Customers Also Bought



TE Part #89-03KA-0U
3K PSIA 316L MV PRESSURE SENSOR



TE Part #2-1393788-2
V23079A1008B301



TE Part #5205865-1
09 PLUG RA/MS STD



TE Part #4-794630-4
14P MICRO MNL ASSY,VRT,HDR,LF

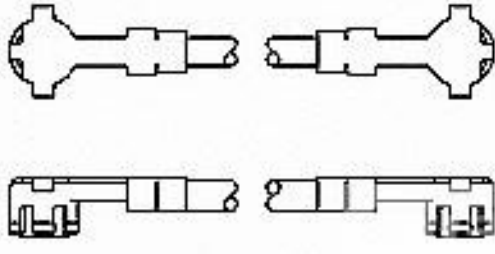

TE Part #1064524-1
9960 1100 24



TE Part #4-1437621-2
KB700B1/4=KNOB KNURL BLACK 1/4



TE Part #2-1747981-3
Std HDMI, RA, SMT, Panel grd, Flange

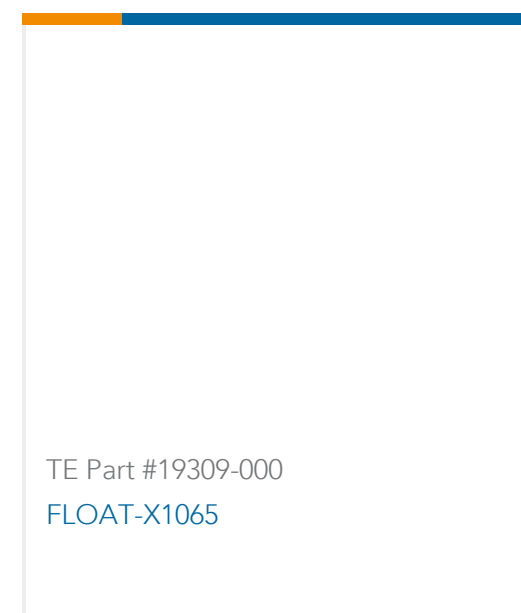

TE Part #19309-000
FLOAT-X1065



TE Part #81568-000
VS-X1030-E SILVER PLATED TERMI

Documents



Product Drawings

SHUNT CONNECTOR

English

CAD Files

Customer View Model

[ENG_CVM_880584-1_L.3d_igs.zip](#)

English

Customer View Model

[ENG_CVM_880584-1_L.3d_stp.zip](#)

English

Customer View Model

[ENG_CVM_880584-1_L.2d_dxf.zip](#)

English

3D PDF

English

By downloading the CAD file I accept and agree to the [Terms and Conditions](#) of use.

Datasheets & Catalog Pages

[AMPMODU_INTERCONNECTION_SYSTEM_SECTION_6_7AND8](#)

English

Product Specifications

[Product Specification](#)

English

Agency Approvals

[Agency Approval Document](#)

English