

6-160432-0 ✓ ACTIVE

FASTON | FASTON 250

TE Internal #: 6-160432-0

Quick Disconnects, Receptacle, 20 – 16 AWG Wire Size, .5 – 1.5 mm² Wire Size, Mating Tab Width 6.35 mm [.25 in], Straight, Phosphor Bronze, FASTON 250

[View on TE.com >](#)



Terminals & Splices > Quick Disconnects

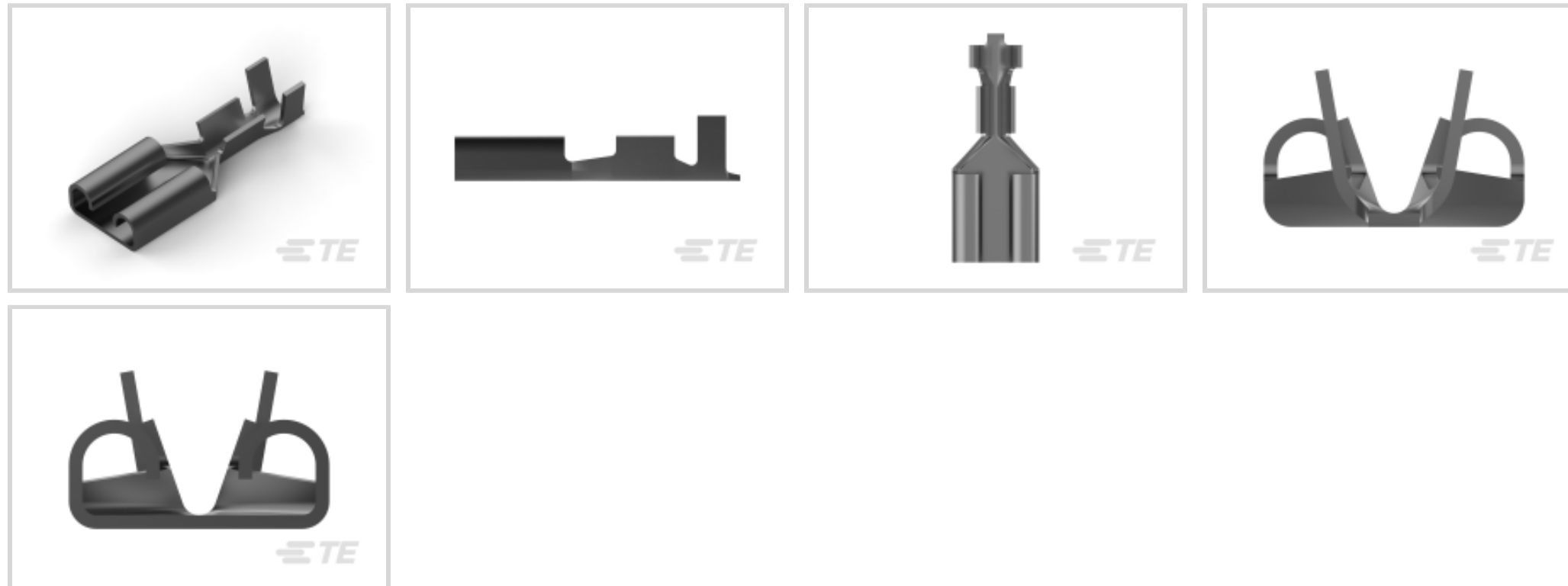

Quick Disconnect Terminal Type: **Receptacle**

Wire Size: .5 – 1.5 mm²

Mating Tab Width: 6.35 mm [.25 in]

Mating Tab Thickness: .81 mm [.032 in]

Features

Product Type Features

Insertion Force	Normal
-----------------	--------

Configuration Features

Connection Capacity	Single
---------------------	--------

Compatible With Wire & Cable Type	Discrete Wire
-----------------------------------	---------------

Contact Features

Quick Disconnect Terminal Type	Receptacle
--------------------------------	------------

Mating Tab Width	6.35 mm [.25 in]
------------------	------------------

Mating Tab Thickness	.81 mm [.032 in]
----------------------	------------------

Terminal Orientation	Straight
----------------------	----------

Contact Base Material	Phosphor Bronze
-----------------------	-----------------

Terminal Plating Material	Tin
---------------------------	-----

Crimp Type	F-Crimp
------------	---------

Barrel Type	Open
-------------	------

Termination Features



Product Terminates To	Wire & Cable
-----------------------	--------------

Mechanical Attachment

Extraction Force	80 Newton
------------------	-----------

Wire Insulation Support	With
-------------------------	------

Mating Retention Type	Dimple
-----------------------	--------

Dimensions

Terminal Material Thickness	.41 mm[.016 in]
-----------------------------	-----------------

Product Length	19 mm[.748 in]
----------------	----------------

Compatible Insulation Diameter Range	2.3 – 3.3 mm[.09 – .13 in]
--------------------------------------	----------------------------

Wire Size	.5 – 1.5 mm ²
-----------	--------------------------

Usage Conditions

Insulation Option	Uninsulated
-------------------	-------------

Operating Temperature Range	-40 – 110 °C[-40 – 230 °F]
-----------------------------	----------------------------

Industry Standards

Agency/Standard	CSA, UL
-----------------	---------

Packaging Features

Packaging Quantity	7000
--------------------	------

Packaging Method	Strip/Reel
------------------	------------

Other

Line	Premier
------	---------

Terminals & Splices Comment	Versions according to DIN 46247, Part 3
-----------------------------	---

Product Compliance

[For compliance documentation, visit the product page on TE.com>](#)

EU RoHS Directive 2011/65/EU	Compliant
------------------------------	-----------

EU ELV Directive 2000/53/EC	Compliant
-----------------------------	-----------

China RoHS 2 Directive MIIT Order No 32, 2016	No Restricted Materials Above Threshold
---	---

EU REACH Regulation (EC) No. 1907/2006	Current ECHA Candidate List: JUNE 2023 (235) Candidate List Declared Against: JUNE 2023 (235) Does not contain REACH SVHC
--	---

Halogen Content	Low Halogen - Br, Cl, F, I < 900 ppm per homogenous material. Also BFR/CFR/PVC
-----------------	--

Free

Solder Process Capability

Not applicable for solder process capability

Product Compliance Disclaimer

This information is provided based on reasonable inquiry of our suppliers and represents our current actual knowledge based on the information they provided. This information is subject to change. The part numbers that TE has identified as EU RoHS compliant have a maximum concentration of 0.1% by weight in homogenous materials for lead, hexavalent chromium, mercury, PBB, PBDE, DBP, BBP, DEHP, DIBP, and 0.01% for cadmium, or qualify for an exemption to these limits as defined in the Annexes of Directive 2011/65/EU (RoHS2). Finished electrical and electronic equipment products will be CE marked as required by Directive 2011/65/EU. Components may not be CE marked. Additionally, the part numbers that TE has identified as EU ELV compliant have a maximum concentration of 0.1% by weight in homogenous materials for lead, hexavalent chromium, and mercury, and 0.01% for cadmium, or qualify for an exemption to these limits as defined in the Annexes of Directive 2000/53/EC (ELV). Regarding the REACH Regulation, the information TE provides on SVHC in articles for this part number is based on the latest European Chemicals Agency (ECHA) 'Guidance on requirements for substances in articles' posted at this URL: <https://echa.europa.eu/guidance-documents/guidance-on-reach>

Compatible Parts



TE Part # 180388-2
250 FASTON,REC.,20-16 AWG,TPBR



TE Part # 180388-5
250 FASTON,REC.,20-16 AWG,TPPB



TE Part # 2150082-1
OCEAN_2.0_APPLICATOR-E-090F130F



TE Part # 2150082-2
OCEAN_2.0_APPLICATOR-E-090F130FA



TE Part # 2376595-2
250 FASTON PCB TAB TPBR



TE Part # 7-2150082-1
OCEAN_2.0_APPLICATOR-E-090F130F



TE Part # 7-2150082-2
OCEAN_2.0_APPLICATOR-E-090F130FA



TE Part # 7-2150082-7
OCEAN_2.0_SPARE_PART_KIT-090F130F



TE Part # 2-2150082-1
OCEAN_2.0_APPLICATOR-E-090F130F



TE Part # 2-2150082-2
OCEAN_2.0_APPLICATOR-E-090F130FA

Also in the Series | **FASTON 250**



Compression Connectors(4)



Crimp Terminal Housings(142)



Insertion & Extraction Tools(6)



Magnet Wire Terminals(1)



PCB Terminals(135)



Quick Disconnects(445)



Splices(4)

Customers Also Bought



TE Part #66098-9
III+ PIN,18-16,30AU/FL,STRIP



TE Part #794942-1
10P MINI UMNL CAP HSG



TE Part #4-2271014-0
CELLO,REC,96P,TH,V,FG,DIP3.0,-

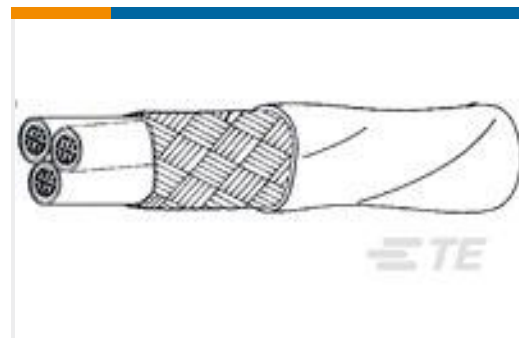

TE Part #382121-006
44A1131-24-0/2/9-9



TE Part #926984-2
STD TIMER CONTACT

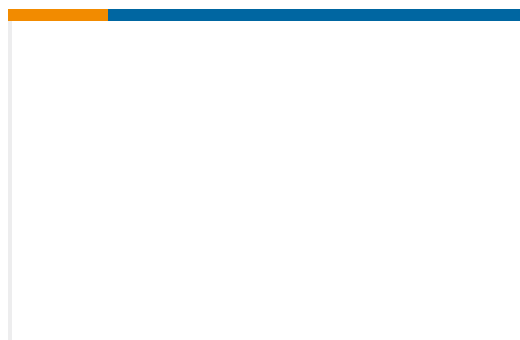

TE Part #AKA020F01620200000
623 EXTENSION, SPEEDTEC-READY

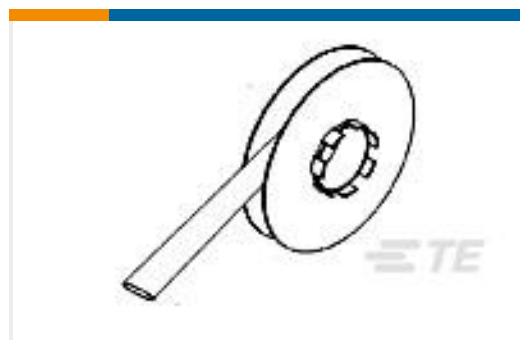

TE Part #141469-000
TTMS-6.4-4



TE Part #1813390001
D-SCE-12-50-S1-4

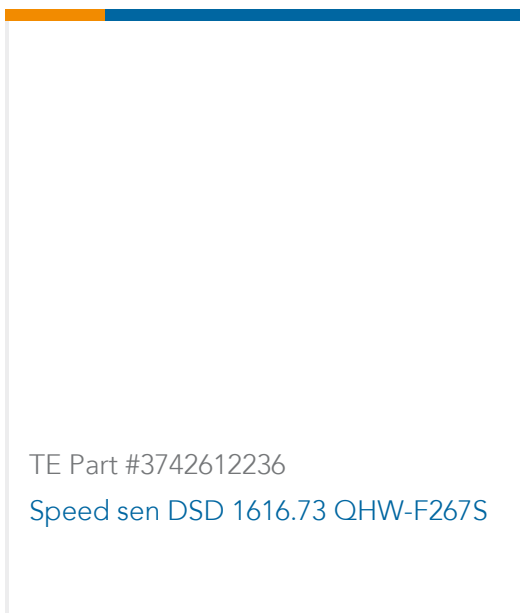

TE Part #3742612236
Speed sen DSD 1616.73 QHW-F267S



TE Part #8202614703
connector 5 pol. KPSE7E14-5P-DZ-BM221

Documents



Product Drawings

[250 FASTON REC 20-16 AWG TPBZ](#)

English

CAD Files

Customer View Model

[ENG_CVM_CVM_6-160432-0_AV.2d_dxf.zip](#)

English

3D PDF

3D

Customer View Model

[ENG_CVM_CVM_6-160432-0_AV.3d_igs.zip](#)

English

Customer View Model

[ENG_CVM_CVM_6-160432-0_AV.3d_stp.zip](#)

English

By downloading the CAD file I accept and agree to the [Terms and Conditions](#) of use.

Datasheets & Catalog Pages

[1654742_HOUSEHOLD_APPLIANCES_RAST5](#)

English

Product Specifications

[Application Specification](#)

English

[Application Specification](#)

English

Product Environmental Compliance

[MD_6-160432-0_04162018239_dmtec](#)

English

[MD_6-160432-0_04162018239_dmtec](#)

English

Agency Approvals

[UL Report](#)

English