

51979-2 ✓ ACTIVE

COPALUM

TE Internal #: 51979-2

Closed Ring Tongue Terminal, 12 – 10 AWG, #10 Stud Size, 5 mm [.197 in] Stud Diameter, Closed Barrel, Straight, Tin, Uninsulated

[View on TE.com >](#)



Terminals & Splices > Ring Terminals



Ring Terminal Product Type: **Closed Ring Tongue Terminal**

Wire Size: **5180 – 13100 CMA**

Stud Size: **#10**

Features

Product Type Features

Shape Description	RING-044
Ring Terminal Product Type	Closed Ring Tongue Terminal
Stud Size	#10
Sealable	No
Wire Insulation Support Retention Type	Non-Insulation Support

Configuration Features

Number of Holes	1
-----------------	---

Body Features

Product Weight	2.724 g
----------------	---------

Contact Features

Barrel Type	Closed
Terminal Orientation	Straight
Terminal Plating Material	Tin
Contact Underplating Material	None

Dimensions

Wire Size	5180 – 13100 CMA
Stud Diameter	5 mm [.197 in]
Tongue Thickness	1.07 mm [.042 in]
Product Length	21.21 mm [.835 in]
Barrel Inside Diameter	6.55 mm [.258 in]



Usage Conditions

Insulation Option	Uninsulated
Operating Temperature Range	-55 – 150 °C[-85 – 347 °F]

Packaging Features

Packaging Quantity	500
Packaging Method	Box

Other

Terminals & Splices Comment	Not approved for reconnection of residential aluminum branch circuit wiring., When two or more wires are used in a parallel splice, the combined cross-sectional area must be within the CMA range listed.
-----------------------------	--

Product Compliance

[For compliance documentation, visit the product page on TE.com>](#)

EU RoHS Directive 2011/65/EU	Compliant
EU ELV Directive 2000/53/EC	Compliant
China RoHS 2 Directive MIIT Order No 32, 2016	No Restricted Materials Above Threshold
EU REACH Regulation (EC) No. 1907/2006	Current ECHA Candidate List: JUNE 2023 (235) Candidate List Declared Against: JAN 2023 (233) Does not contain REACH SVHC
Halogen Content	Low Halogen - Br, Cl, F, I < 900 ppm per homogenous material. Also BFR/CFR/PVC Free
Solder Process Capability	Not applicable for solder process capability

Product Compliance Disclaimer

This information is provided based on reasonable inquiry of our suppliers and represents our current actual knowledge based on the information they provided. This information is subject to change. The part numbers that TE has identified as EU RoHS compliant have a maximum concentration of 0.1% by weight in homogenous materials for lead, hexavalent chromium, mercury, PBB, PBDE, DBP, BBP, DEHP, DIBP, and 0.01% for cadmium, or qualify for an exemption to these limits as defined in the Annexes of Directive 2011/65/EU (RoHS2). Finished electrical and electronic equipment products will be CE marked as required by Directive 2011/65/EU. Components may not be CE marked. Additionally, the part numbers that TE has identified as EU ELV compliant have a maximum concentration of 0.1% by weight in homogenous materials for lead, hexavalent chromium, and mercury, and 0.01% for cadmium, or qualify for an exemption to these limits as defined in the Annexes of Directive 2000/53/EC (ELV). Regarding the REACH Regulation, the information TE provides on SVHC in articles for this part number is based on the latest European Chemicals Agency (ECHA) 'Guidance on requirements for substances in articles' posted at this URL: <https://echa.europa.eu/guidance-documents/guidance-on-reach>

Compatible Parts

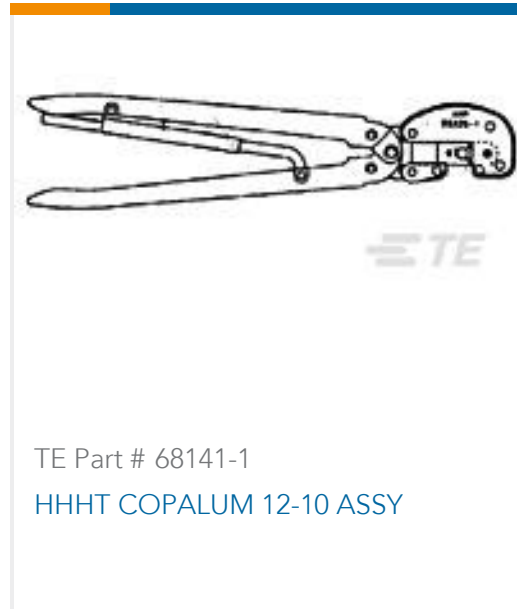

Customers Also Bought

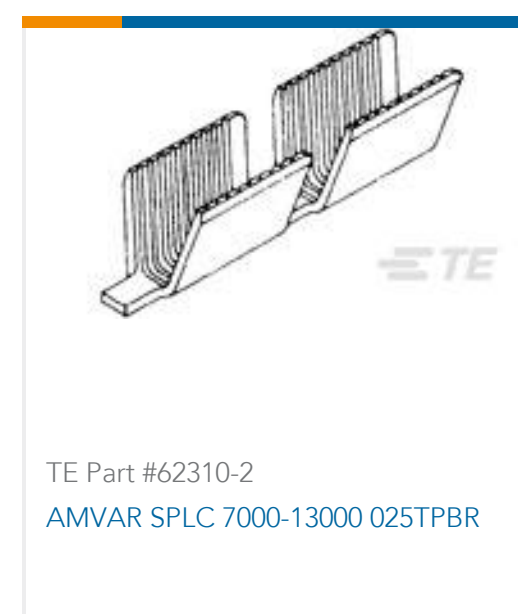
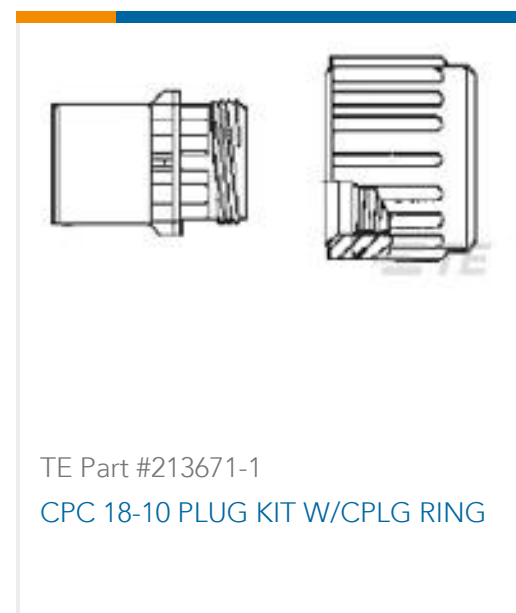
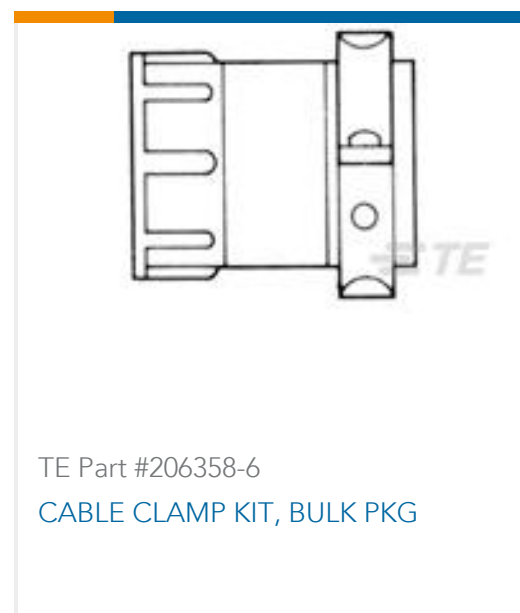

Documents

Product Drawings

[TERMINAL,COPALUM 12-10 10](#)

English

CAD Files

Customer View Model

[ENG_CVM_51979-2_J.3d_igs.zip](#)

English



Customer View Model

[ENG_CVM_51979-2_J.3d_stp.zip](#)

English

Customer View Model

[ENG_CVM_51979-2_J.2d_dxf.zip](#)

English

3D PDF

English

By downloading the CAD file I accept and agree to the [Terms and Conditions](#) of use.

Datasheets & Catalog Pages

[COPALUM Lite Sealed Terminals and Splices](#)

English

Product Specifications

[Application Specification](#)

English

[COPALUM Terminals And Splices For Solid And Stranded Wire](#)

English

[Application Specification](#)

Japanese

[Copalum Terminals & Splices f/Solid & Stranded Wire](#)

Japanese

Agency Approvals

[UL Report](#)

English

[UL Report](#)

English