



AMP | AMP Superseal 1.5mm Series

TE Internal #: 282109-3

Automotive Terminals, Tab, Mating Tab Width 1.5 mm [.059 in], Tab Thickness .8 mm [.031 in], 18 – 15 AWG Wire Size, AMP Superseal 1.5mm Series

[View on TE.com >](#)

Terminals & Splices > Automotive Terminals > AMP SUPERSEAL 1.5MM, RECEPTACLE AND TAB

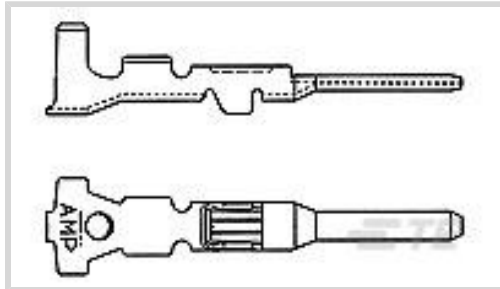

Terminal Type: **Tab**

Mating Tab Width: **1.5 mm [.059 in]**

Mating Tab Thickness: **.8 mm [.031 in]**

Terminal Transmits: **0 – 24 A (Low Power)**

Wire Size: **18 – 15 AWG**

[All AMP SUPERSEAL 1.5MM, RECEPTACLE AND TAB \(17\)](#)

Features

Product Type Features

Receptacle Style	180°
Sealable	Yes
Primary Locking Feature	Clean Body

Body Features

Terminal Seal Type	Single Wire Seal (SWS)
--------------------	------------------------

Contact Features

Contact Size	1.5mm
Contact Fabrication	Stamped & Formed
Wire Contact Termination Area Plating Material	Gold
Typical Current Rating	14 A
Crimp Type	F-Crimp
Terminal Type	Tab
Mating Tab Width	1.5 mm[.059 in]
Mating Tab Thickness	.8 mm[.031 in]
Interface Plating	Other

Termination Features

Termination Method to Wire & Cable	Crimp
------------------------------------	-------



Product Terminates To	Wire
-----------------------	------

Dimensions

Compatible Insulation Diameter Range	1.7 – 2.4 mm [.071 – .13 in]
Wire Size	.75 – 1.5 mm ²
Wire Size Search	15 AWG, 16 AWG, 17 AWG, 18 AWG

Usage Conditions

Insulation Option	Uninsulated
Operating Temperature (Max)	80 °C, 85 °C, 90 °C, 100 °C, 105 °C, 110 °C, 120 °C, 125 °C [176 °F][185 °F][194 °F][212 °F][221 °F][230 °F][248 °F][257 °F]
Operating Temperature Range	-40 – 125 °C [-40 – 257 °F]

Operation/Application

Compatible With Wire Base Material	Copper
------------------------------------	--------

Packaging Features

Packaging Quantity	4000
Packaging Method	Reel

Other

Terminal Transmits	0 – 24 A (Low Power)
--------------------	----------------------

Product Compliance

[For compliance documentation, visit the product page on TE.com>](#)

EU RoHS Directive 2011/65/EU	Compliant
EU ELV Directive 2000/53/EC	Compliant
China RoHS 2 Directive MIIT Order No 32, 2016	No Restricted Materials Above Threshold
EU REACH Regulation (EC) No. 1907/2006	Current ECHA Candidate List: JUNE 2023 (235) Candidate List Declared Against: JUNE 2023 (235) Does not contain REACH SVHC
Halogen Content	Low Halogen - Br, Cl, F, I < 900 ppm per homogenous material. Also BFR/CFR/PVC Free
Solder Process Capability	Not applicable for solder process capability

Product Compliance Disclaimer

This information is provided based on reasonable inquiry of our suppliers and represents our current actual knowledge based on the information they provided. This information is subject to change. The part numbers that TE has identified as EU RoHS compliant have a maximum concentration of 0.1% by weight in homogenous materials for lead, hexavalent chromium, mercury, PBB, PBDE, DBP, BBP, DEHP, DIBP, and 0.01% for cadmium, or qualify for an exemption to these limits as defined in the Annexes of Directive 2011/65/EU (RoHS2). Finished electrical and electronic equipment products will be CE marked as required by Directive 2011/65/EU. Components may not be CE marked. Additionally, the part numbers that TE has identified as EU ELV compliant have a maximum concentration of 0.1% by weight in homogenous materials for lead, hexavalent chromium, and mercury, and 0.01% for cadmium, or qualify for an exemption to these limits as defined in the Annexes of Directive 2000/53/EC (ELV). Regarding the REACH Regulation, the information TE provides on SVHC in articles for this part number is based on the latest European Chemicals Agency (ECHA) 'Guidance on requirements for substances in articles' posted at this URL: <https://echa.europa.eu/guidance-documents/guidance-on-reach>

Compatible Parts



TE Part # CAT-AM71-CH8172
AMP SUPERSEAL 1.5MM,
CONNECTOR HOUSING



TE Part # 58583-1
PROCRIMP HT&D SUPRSEAL 1.5 SER



TE Part # 9-1579007-1
EXTRACTION TOOL

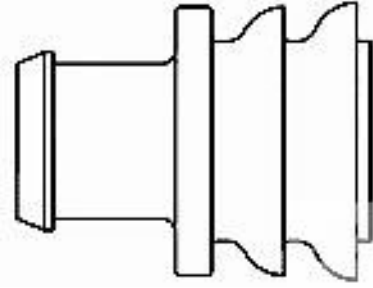

TE Part # 282081-1
RUBBER PLUG

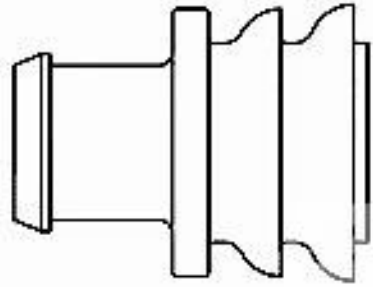

TE Part # 281934-2
SINGLE WIRE SEAL



TE Part # 58583-2
PROCRIMP DIE SUPERSEAL 1.5 SER



TE Part # 2305570-1
Strip Terminal Cutter-Side Feed-No
Crimp



TE Part # 282403-1
MINI MIC SRS REC CONT



TE Part # 2151204-1
OCEAN-2.0-APPLICATOR-S-090F1450



TE Part # 1745099-1
AMP SUPERSEAL 1,5 SRS. 2 POS. TAB
ASS'Y



TE Part # 2031676-1
SDE F MINI MIC 0.35-1.5mm2 ASSY



TE Part # 2031676-2
SDE F MINI MIC 0.35-1.5mm2 DIE SET



TE Part # 2151204-2
OCEAN-2.0-APPLICATOR-S-090F1450



TE Part # 5-2151204-1
OCEAN-2.0-APPLICATOR-S-090F1450



TE Part # 5-2151204-2
OCEAN-2.0-APPLICATOR-S-090F1450



TE Part # 7-2151204-1
OCEAN-2.0-APPLICATOR-S-090F1450



TE Part # 7-2151204-2
OCEAN-2.0-APPLICATOR-S-090F1450



KIT
REPRESENTATION ONLY

TE Part # 7-2151204-7
OCEAN_2.0_SPARE_PART_KIT-090F1450



KIT
REPRESENTATION ONLY

TE Part # 7-2266068-7
OC-090F1450-CRIMPTOOLINGKIT



TE Part # 539773-2
DIE FUER MINI MIC

Also in the Series | **AMP Superseal 1.5mm Series**

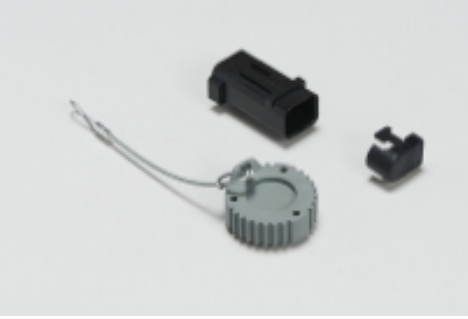

Automotive Connector Caps & Covers (2)



Automotive Housings(29)

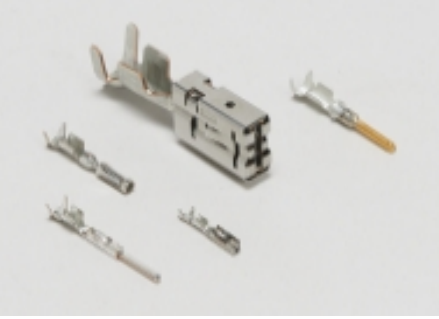

Automotive Terminals(17)



Connector Seals & Cavity Plugs(4)



Insertion & Extraction Tools(3)



Other Automotive Connector Accessories(2)

Customers Also Bought

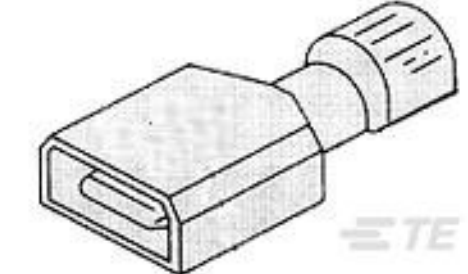

TE Part #2-520102-1
ULTRA-FAST 250 ASSEMBLY TAB 22-18 AWG BR



TE Part #1546310-4
4P .563" DR BARRIER STRIP



TE Part #41616
250 FASTON TAB BR



TE Part #2151164-1
OCEAN_2.0-APPLICATOR-S-080F100OV



TE Part #2151237-2
OCEAN_2.0-Applicator-S-052F059F



TE Part #1-2191666-3
KTHV-RSTI-6823R-HT-500



TE Part #1-2344223-1
HVTE-RFK1-476



TE Part #HD44-18-14PN
KT RC HD30 18 SHL 14 WY N SEAL

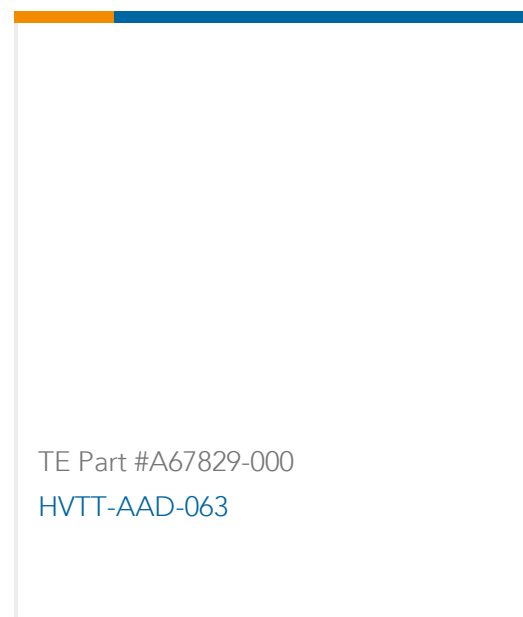
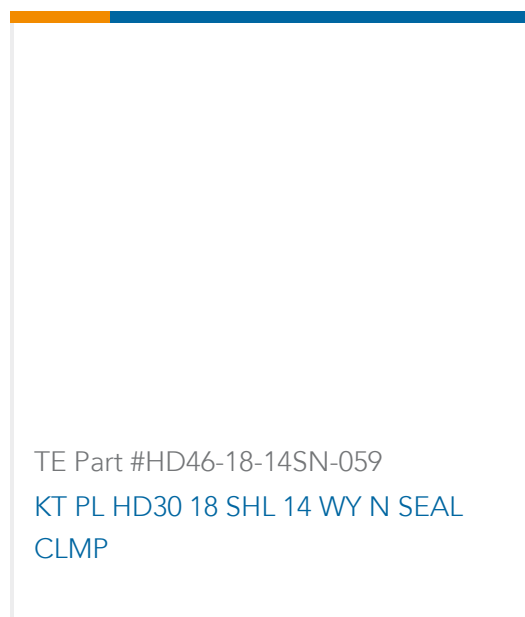

Documents

Product Drawings

[MINI MIC TAB CONTACT](#)

English

CAD Files

[3D PDF](#)

3D

[Customer View Model](#)

[ENG_CVM_CVM_282109-3_E.2d_dxf.zip](#)

English

[Customer View Model](#)

[ENG_CVM_CVM_282109-3_E.3d_igs.zip](#)

English

[Customer View Model](#)

[ENG_CVM_CVM_282109-3_E.3d_stp.zip](#)

English

By downloading the CAD file I accept and agree to the [Terms and Conditions](#) of use.

Datasheets & Catalog Pages

[AMP SUPERSEAL 1.5mm Connector System](#)

English

[ICT Terminals and Connectors Catalogue](#)

English

Product Specifications

[Application Specification](#)

English

[Application Specification](#)

English