



Application Tooling > Heat Shrink Equipment



Heat Shrink Equipment Region: **Worldwide**

### Features

#### Product Availability

Heat Shrink Equipment Region	Worldwide
------------------------------	-----------

### Product Compliance

[For compliance documentation, visit the product page on TE.com>](#)

EU RoHS Directive 2011/65/EU	Out of Scope
EU ELV Directive 2000/53/EC	Out of Scope
China RoHS 2 Directive MIIT Order No 32, 2016	No Restricted Materials Above Threshold
EU REACH Regulation (EC) No. 1907/2006	Current ECHA Candidate List: JUNE 2023 (235) Candidate List Declared Against: JUL 2021 (219) Does not contain REACH SVHC
Halogen Content	Low Halogen - Br, Cl, F, I < 900 ppm per homogenous material. Also BFR/CFR/PVC Free
Solder Process Capability	Not applicable for solder process capability

#### Product Compliance Disclaimer

This information is provided based on reasonable inquiry of our suppliers and represents our current actual knowledge based on the information they provided. This information is subject to change. The part numbers that TE has identified as EU RoHS compliant have a maximum concentration of 0.1% by weight in homogenous materials for lead, hexavalent chromium, mercury, PBB, PBDE, DBP, BBP, DEHP, DIBP, and 0.01% for cadmium, or qualify for an exemption to these limits as defined in the Annexes of Directive 2011/65/EU (RoHS2). Finished electrical and electronic equipment products will be CE marked as required by Directive 2011/65/EU. Components may not be CE marked. Additionally, the part numbers that TE has identified as EU ELV compliant have a maximum concentration of 0.1% by weight in homogenous materials for lead, hexavalent chromium, and mercury, and 0.01% for cadmium, or qualify for an exemption to these limits as defined in the Annexes of Directive 2000/53/EC (ELV). Regarding the REACH Regulation, the information TE provides on SVHC in articles for this part number is based on the latest European Chemicals Agency (ECHA) 'Guidance on requirements for substances in articles' posted at this URL: <https://echa.europa.eu/guidance-documents/guidance-on-reach>

## Compatible Parts



## Customers Also Bought

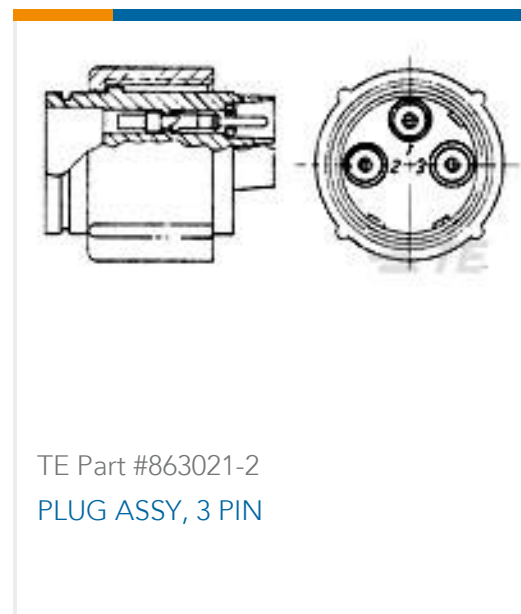

## Documents

### Instruction Sheets

[HEAT SHRINK EQUIPMENT DOCUMENTATION REQUEST](#)

[HEAT SHRINK EQUIPMENT DOCUMENTATION REQUEST](#)

[HEAT SHRINK EQUIPMENT DOCUMENTATION REQUEST](#)

[HEAT SHRINK EQUIPMENT DOCUMENTATION REQUEST](#)



HEAT SHRINK EQUIPMENT DOCUMENTATION REQUEST

HEAT SHRINK EQUIPMENT DOCUMENTATION REQUEST

HEAT SHRINK EQUIPMENT DOCUMENTATION REQUEST

German

HEAT SHRINK EQUIPMENT DOCUMENTATION REQUEST

HEAT SHRINK EQUIPMENT DOCUMENTATION REQUEST

HEAT SHRINK EQUIPMENT DOCUMENTATION REQUEST

English

HEAT SHRINK EQUIPMENT DOCUMENTATION REQUEST

HEAT SHRINK EQUIPMENT DOCUMENTATION REQUEST

HEAT SHRINK EQUIPMENT DOCUMENTATION REQUEST

HEAT SHRINK EQUIPMENT DOCUMENTATION REQUEST

HEAT SHRINK EQUIPMENT DOCUMENTATION REQUEST

Japanese

HEAT SHRINK EQUIPMENT DOCUMENTATION REQUEST

HEAT SHRINK EQUIPMENT DOCUMENTATION REQUEST

HEAT SHRINK EQUIPMENT DOCUMENTATION REQUEST

HEAT SHRINK EQUIPMENT DOCUMENTATION REQUEST

French