

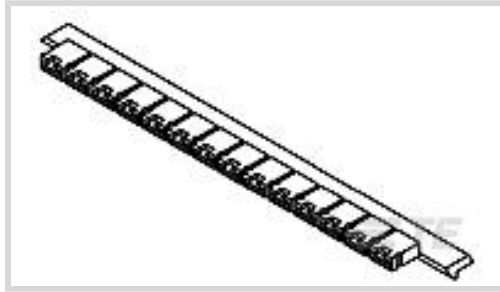

Connectors > PCB Connectors > Board-to-Board Connectors > Board-to-Board Jumpers & Shunts



Shunt Style: **Open Top**

Connector System: **Board-to-Board**

Number of Positions: **2**

Centerline (Pitch): **2.54 mm [.1 in]**

Connector & Contact Terminates To: **Printed Circuit Board**

Features

Product Type Features

Connector System	Board-to-Board
Connector & Contact Terminates To	Printed Circuit Board

Configuration Features

Number of Positions	2
---------------------	---

Body Features

Handle	Without
Primary Product Color	Green

Contact Features

Contact Mating Area Plating Material Thickness	1 μ m[39.37 μ m]
Contact Mating Area Plating Material	Gold
Contact Base Material	Beryllium Copper
Shunt Style	Open Top
Contact Current Rating (Max)	3 A

Housing Features

Housing Material	Glass Filled PBT
Centerline (Pitch)	2.54 mm[.1 in]

Dimensions

Product Height	6.3 mm[.248 in]
----------------	-----------------



Usage Conditions

Operating Temperature Range	-55 – 125 °C[-67 – 257 °F]
-----------------------------	----------------------------

Operation/Application

Circuit Application	Signal
---------------------	--------

Industry Standards

Approved Standards	CSA Certified, UL Recognized
--------------------	------------------------------

UL Flammability Rating	UL 94V-0
------------------------	----------

Packaging Features

Jumper & Shunt Packaging	Breakaway Strip of 14 Pieces
--------------------------	------------------------------

Packaging Quantity	1400
--------------------	------

Packaging Method	Box
------------------	-----

Product Compliance

[For compliance documentation, visit the product page on TE.com>](#)

EU RoHS Directive 2011/65/EU	Compliant
------------------------------	-----------

EU ELV Directive 2000/53/EC	Compliant
-----------------------------	-----------

China RoHS 2 Directive MIIT Order No 32, 2016	No Restricted Materials Above Threshold
---	---

EU REACH Regulation (EC) No. 1907/2006	Current ECHA Candidate List: JUNE 2023 (235) Candidate List Declared Against: JUNE 2023 (235) Does not contain REACH SVHC
--	---

Halogen Content	Not Low Halogen - contains Br or Cl > 900 ppm.
-----------------	--

Solder Process Capability	Not applicable for solder process capability
---------------------------	--

Product Compliance Disclaimer

This information is provided based on reasonable inquiry of our suppliers and represents our current actual knowledge based on the information they provided. This information is subject to change. The part numbers that TE has identified as EU RoHS compliant have a maximum concentration of 0.1% by weight in homogenous materials for lead, hexavalent chromium, mercury, PBB, PBDE, DBP, BBP, DEHP, DIBP, and 0.01% for cadmium, or qualify for an exemption to these limits as defined in the Annexes of Directive 2011/65/EU (RoHS2). Finished electrical and electronic equipment products will be CE marked as required by Directive 2011/65/EU. Components may not be CE marked. Additionally, the part numbers that TE has identified as EU ELV compliant have a maximum concentration of 0.1% by weight in homogenous materials for lead, hexavalent chromium, and mercury, and 0.01% for cadmium, or qualify for an exemption to these limits as defined in the Annexes of Directive 2000/53/EC (ELV). Regarding the REACH Regulation, the information TE provides on SVHC in articles for this part number is based on the latest European Chemicals Agency (ECHA) 'Guidance on requirements for substances in articles' posted at this URL: <https://echa.europa.eu/guidance-documents/guidance-on-reach>

Compatible Parts



Customers Also Bought

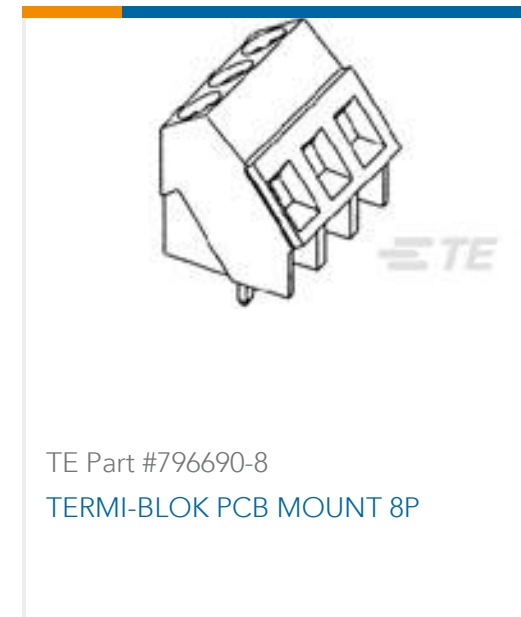
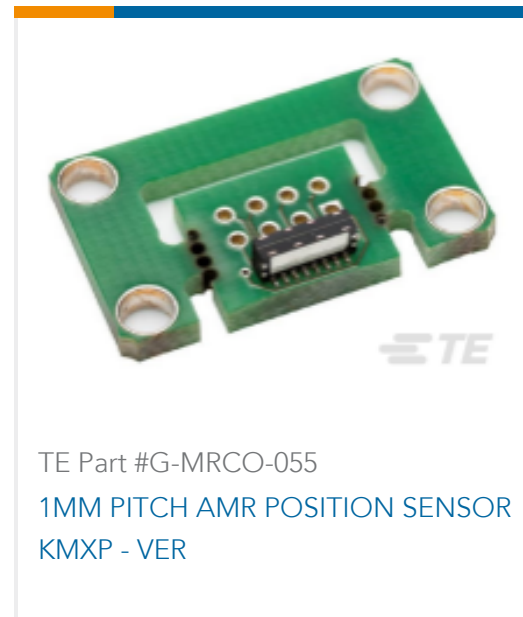

Documents

[Product Drawings](#)
[CONNECTOR SHUNT 2 P](#)

English

[CAD Files](#)

[3D PDF](#)

[3D](#)



Customer View Model

[ENG_CVM_CVM_142270-5_D.2d_dxf.zip](#)

English

Customer View Model

[ENG_CVM_CVM_142270-5_D.3d_igs.zip](#)

English

Customer View Model

[ENG_CVM_CVM_142270-5_D.3d_stp.zip](#)

English

By downloading the CAD file I accept and agree to the [Terms and Conditions](#) of use.

Product Specifications

Product Specification

English

[STRAP D'INTERCONNEXION AU PAS DE 2,54 mm](#)

English

Product Environmental Compliance

TE Material Declaration

English

[MD_142270-5_10282015627_dmtec](#)

English

[MD_142270-5_10282015627_dmtec](#)

English