

1326132-1 ✓ ACTIVE

AMP 0.64 Connector System

TE Internal #: 1326132-1

Automotive Connector Caps & Covers, Shield Assembly, Cable Exit Angle 70°, Black, Nylon GF, 18 Position, AMP 0.64 Connector System

[View on TE.com >](#)



Connectors > Automotive Connectors > Automotive Connector Accessories > Automotive Connector Caps & Covers



Protection & Strain Relief Accessory Type: **Shield Assembly**

Cable Exit Angle: **70°**

Strain Relief: **With**

Primary Product Color: **Black**

Primary Product Material: **Nylon GF**

Features

Product Type Features

Protection & Strain Relief Accessory Type	Shield Assembly
---	-----------------

Configuration Features

Compatible With Connector Code	C-F
Number of Positions	18

Body Features

Cable Exit Angle	70°
Primary Product Color	Black
Primary Product Material	Nylon GF

Mechanical Attachment

Strain Relief	With
---------------	------

Packaging Features

Packaging Quantity	1
Packaging Method	Package

Other

Serviceable	No
-------------	----

Product Compliance

[For compliance documentation, visit the product page on TE.com>](#)



EU RoHS Directive 2011/65/EU	Compliant
EU ELV Directive 2000/53/EC	Compliant
China RoHS 2 Directive MIIT Order No 32, 2016	No Restricted Materials Above Threshold
EU REACH Regulation (EC) No. 1907/2006	Current ECHA Candidate List: JUNE 2023 (235) Candidate List Declared Against: JUNE 2023 (235) Does not contain REACH SVHC
Halogen Content	Low Halogen - Br, Cl, F, I < 900 ppm per homogenous material. Also BFR/CFR/PVC Free
Solder Process Capability	Not reviewed for solder process capability

Product Compliance Disclaimer

This information is provided based on reasonable inquiry of our suppliers and represents our current actual knowledge based on the information they provided. This information is subject to change. The part numbers that TE has identified as EU RoHS compliant have a maximum concentration of 0.1% by weight in homogenous materials for lead, hexavalent chromium, mercury, PBB, PBDE, DBP, BBP, DEHP, DIBP, and 0.01% for cadmium, or qualify for an exemption to these limits as defined in the Annexes of Directive 2011/65/EU (RoHS2). Finished electrical and electronic equipment products will be CE marked as required by Directive 2011/65/EU. Components may not be CE marked. Additionally, the part numbers that TE has identified as EU ELV compliant have a maximum concentration of 0.1% by weight in homogenous materials for lead, hexavalent chromium, and mercury, and 0.01% for cadmium, or qualify for an exemption to these limits as defined in the Annexes of Directive 2000/53/EC (ELV). Regarding the REACH Regulation, the information TE provides on SVHC in articles for this part number is based on the latest European Chemicals Agency (ECHA) 'Guidance on requirements for substances in articles' posted at this URL: <https://echa.europa.eu/guidance-documents/guidance-on-reach>

Compatible Parts

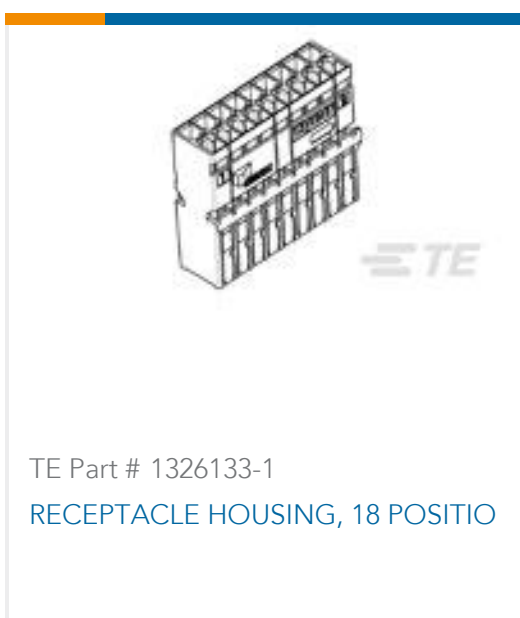

Also in the Series | AMP 0.64 Connector System



Automotive Connector Caps & Covers (20)



Automotive Housings(35)



Automotive Terminals(15)



Insertion & Extraction Tools(1)



Other Automotive Connector Accessories(2)

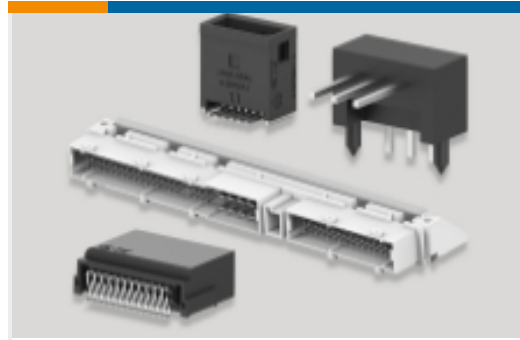

PCB Headers & Receptacles(43)

Customers Also Bought



TE Part #DRCP25-86PAA-G005
HDR, 86P, BLK, ST, 12/20, SN/NI/CU, AA



TE Part #DRCP25-86PBB-GC05
HDR, 86P, BLK, ST, 12/20, SN/NI/CU, BB



TE Part #1924639-1
1X8 FEMALE ASSY KEY C, LP LATC

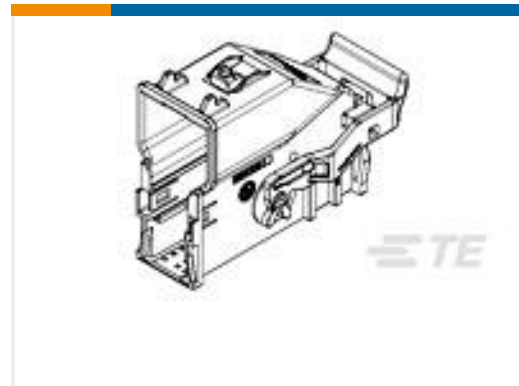

TE Part #1924337-1
Shield Assembly, 54 POSN, 0.64mm BLK

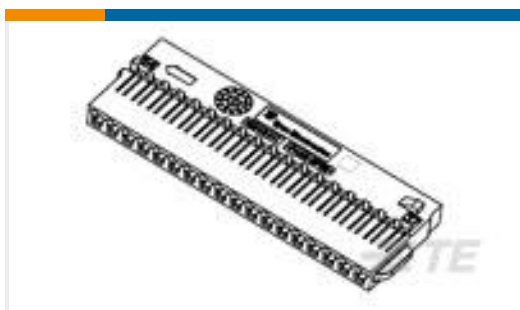

TE Part #1924341-1
18P, 1 Row Carrier for 54P LAC



TE Part #2098660-1
32P Shield, GY HandMate



TE Part #2035360-1
1X4 GENERATION Y ASSY KEY A



TE Part #0942318R02
DTP RECP ASM



TE Part #2324930-1
REC CONN CVR ASSY,40POS,HYBRID



TE Part #DRCP25-86PCC-GC05
HDR, 86P, BLK, ST, 12/20, SN/NI/CU, CC

Documents



Product Drawings

18WAY LAC SHIELD ASSEMBLY 70 D

English

CAD Files

3D PDF

English

Customer View Model

[ENG_CVM_1326132-1_A.2d_dxf.zip](#)

English

Customer View Model

[ENG_CVM_1326132-1_A.3d_igs.zip](#)

English

Customer View Model

[ENG_CVM_1326132-1_A.3d_stp.zip](#)

English

By downloading the CAD file I accept and agree to the [Terms and Conditions](#) of use.

Instruction Sheets

Instruction Sheet (U.S.)

English