

Technical Datasheet

QSFP-40G-SR-BD-MSA-AT

Universally Coded MSA Compliant 40GBase-SR BD QSFP+ BiDi Transceiver

Hot Pluggable, Duplex LC, 850/900nm, up to 150m, Commercial Temperature

FEATURES

- Compliant to the 40GbE XLPPPI electrical specification per IEEE 802.3ba-2010
- Compliant to QSFP+ SFF-8436 Specification
- QSFP MSA compliant
- Aggregate bandwidth of > 40Gbps
- Operates at 10.3125 Gbps per electrical channel with 64b/66b encoded data
- Capable of over 100m transmission on OM3 Multimode Fiber (MMF) and 150m on OM4 MMF
- Single +3.3V power supply operating
- Built-in digital diagnostic functions
- Commercial Operating Temperature Range: +10 to 70°C
- RoHS Compliant Part
- Utilizes a standard LC duplex fiber cable allowing reuse of existing cable infrastructure

APPLICATIONS

- 40 Gigabit Ethernet interconnects
- Datacom/Telecom switch & router connections
- Data aggregation and backplane applications
- Proprietary protocol and density applications

DESCRIPTION

ATGBICS® Universally Coded MSA Compliant QSFP-40G-SR-BD-MSA-AT is a Four-Channel, Pluggable, LC Duplex, Fiber-Optic QSFP+ Transceiver for 40 Gigabit Ethernet Applications. This transceiver is a high-performance module for short-range duplex data communication and interconnect applications. It integrates four electrical data lanes in each direction into transmission over a single LC duplex fiber optic cable. Each electrical lane operates at 10.3125 Gbps and conforms to the 40GE XLPPPI interface.

The transceiver internally multiplexes an XLPPPI 4x10G interface into two 20Gb/s electrical channels, transmitting and receiving each optically over one simplex LC fiber using bi-directional optics. This results in an aggregate bandwidth of 40Gbps into a duplex LC cable. This allows reuse of the installed LC duplex cabling infrastructure for 40GbE application. Link distances up to 100 m using OM3 and 150m using OM4 optical fiber are supported. These modules are designed to operate over multimode fiber systems using a nominal wavelength of 850nm on one end and 900nm on the other end. The electrical interface uses a 38 contact QSFP+ type edge connector. The optical interface uses a conventional LC duplex connector.

Technical Datasheet

Transceiver Block Diagram

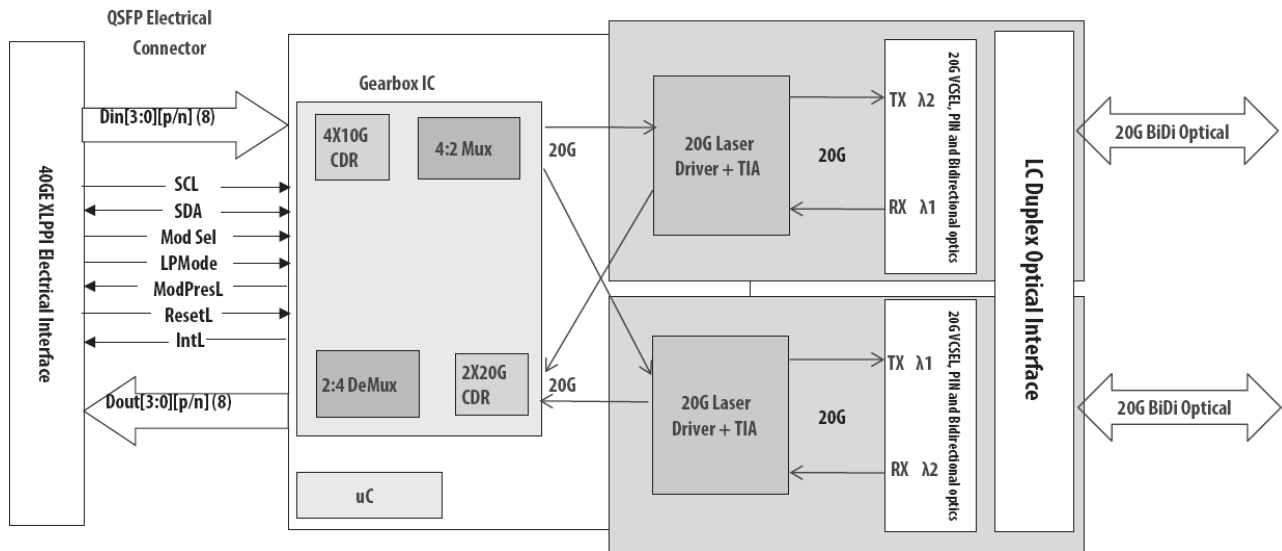

Figure 1. Transceiver Block Diagram

Absolute Maximum Ratings

Parameter	Symbol	Min.	Typical	Max.	Unit
Storage Temperature	T _s	-40		+85	°C
Supply Voltage	V _{CC} T, R	-0.5		4	V
Relative Humidity	RH	0		85	%

Recommended Operating Environment

Parameter	Symbol	Min.	Typical	Max.	Unit
Case operating Temperature	T _o	+10		+70	°C
Supply Voltage	V _{CC} T, R	+3.13	3.3	+3.47	V
Supply Current	I _{CC}			1000	mA
Power Dissipation	PD			3.5	W

Technical Datasheet

Electrical Characteristics (T_o = +10 to 70 °C, V_{cc} = 3.13 to 3.47 Volts)

Parameter	Symbol	Min	Typ	Max	Unit	Note
Data Rate per Channel		-	10.3125	11.2	Gbps	
Power Consumption		-	2.5	3.5	W	
Supply Current	I _{cc}		0.75	1.0	A	
Control I/O Voltage-High	V _{IH}	2.0		V _{cc}	V	
Control I/O Voltage-Low	V _{IL}	0		0.7	V	
Inter-Channel Skew	TSK			150	Ps	
RESETL Duration			10		Us	
RESETL De-assert time				100	ms	
Power On Time				100	ms	
Transmitter						
Single Ended Output Voltage Tolerance		0.3		4	V	1
Common mode Voltage Tolerance		15			mV	
Transmit Input Diff Voltage	V _I	120		1200	mV	
Transmit Input Diff Impedance	Z _{IN}	80	100	120		
Data Dependent Input Jitter	DDJ			0.1	UI	
Data Input Total Jitter	T _J			0.28	UI	
Receiver						
Single Ended Output Voltage Tolerance		0.3		4	V	
Rx Output Diff Voltage	V _o		600	800	mV	
Rx Output Rise and Fall Voltage	Tr/Tf			35	ps	1
Total Jitter	T _J			0.7	UI	
Deterministic Jitter	DJ			0.42	UI	

Note:

1. 20~80%

Technical Datasheet

Optical Parameters (T_o = +10 to 70 °C, V_{cc} = 3.0 to 3.6 Volts)

Parameter	Symbol	Min	Typ	Max	Unit	Ref.
Transmitter						
Optical Wavelength CH1	λ	832	850	868	nm	
Optical Wavelength CH2	λ	882	900	918	nm	
RMS Spectral Width	Pm		0.5	0.65	nm	
Average Optical Power per Channel	Pavg	-4	-2.5	+5.0	dBm	
Laser Off Power Per Channel	Poff			-30	dBm	
Optical Extinction Ratio	ER	3.5			dB	
Relative Intensity Noise	Rin			-128	dB/HZ	1
Optical Return Loss Tolerance				12	dB	
Receiver						
Optical Center Wavelength CH1	λ	882	900	918	nm	
Optical Center Wavelength CH2	λ	832	850	868	nm	
Receiver Sensitivity per Channel	R		-11		dBm	
Maximum Input Power	P _{MAX}	+0.5			dBm	
Receiver Reflectance	R _{rx}			-12	dB	
LOS De-Assert	LOS _b			-14	dBm	
LOS Assert	LOS _A	-30			dBm	
LOS Hysteresis	LOS _H	0.5			dB	

Note:

- 12dB Reflection

Technical Datasheet

Diagnostic Monitoring Interface

Digital diagnostics monitoring function is available on all QSFP+ SRBD. A 2-wire serial interface provides user to contact with module. The structure of the memory is shown in flowing. The memory space is arranged into a lower, single page, address space of 128 bytes and multiple upper address space pages. This structure permits timely access to addresses in the lower page, such as Interrupt Flags and Monitors. Less time critical time entries, such as serial ID information and threshold settings, are available with the Page Select function. The interface address used is A0xh and is mainly used for time critical data like interrupt handling in order to enable a one-time-read for all data related to an interrupt situation. After an interrupt, IntL, has been asserted, the host can read out the flag field to determine the affected channel and type of flag.

Byte Address	Description	Type
0	Identifier (1 Byte)	Read Only
1-2	Status (2 Bytes)	Read Only
3-21	Interrupt Flags (31 Bytes)	Read Only
22-33	Module Monitors (12 Bytes)	Read Only
34-81	Channel Monitors (48 Bytes)	Read Only
82-85	Reserved (4 Bytes)	Read Only
86-97	Control (12 Bytes)	Read/Write
98-99	Reserved (2 Bytes)	Read/Write
100-106	Module and Channel Masks (7 Bytes)	Read/Write
107-118	Reserved (12 Bytes)	Read/Write
119-122	Reserved (4 Bytes)	Read/Write
123-126	Reserved (4 Bytes)	Read/Write
127	Page Select Byte	Read/Write

Byte Address	Description	Type
128-175	Module Thresholds (48 Bytes)	Read Only
176-223	Reserved (48 Bytes)	Read Only
224-225	Reserved (2 Bytes)	Read Only
226-239	Reserved (14 Bytes)	Read/Write
240-241	Channel Controls (2 Bytes)	Read/Write
242-253	Reserved (12 Bytes)	Read/Write
254-255	Reserved (2 Bytes)	Read/Write

Technical Datasheet

2-wire serial address, 1010000x (A0h)"

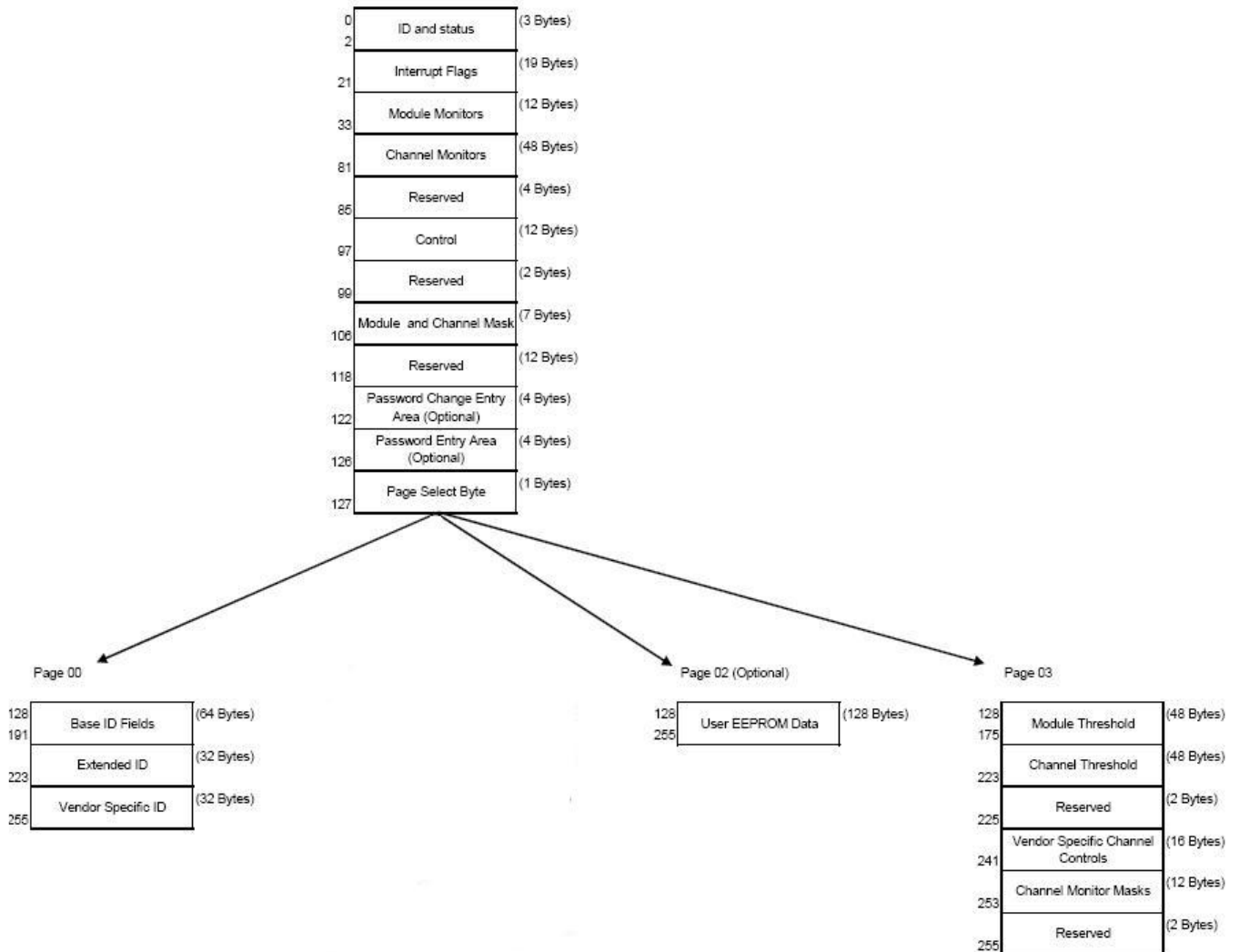

Technical Datasheet

Address	Name	Description
128	Identifier (1 Byte)	Identifier Type of serial transceiver
129	Ext. Identifier (1 Byte)	Extended identifier of serial transceiver
130	Connector (1 Byte)	Code for connector type
131-138	Transceiver (8 Bytes)	Code for electronic compatibility or optical compatibility
139	Encoding (1 Byte)	Code for serial encoding algorithm
140	BR, nominal (1 Byte)	Nominal bit rate, units of 100 Mbits/s
141	Extended RateSelect Compliance (1 Byte)	Tags for Extended RateSelect compliance
142	Length SMF (1 Byte)	Link length supported for SM fiber in km
143	Length E-50 μm (1 Byte)	Link length supported for EBW 50/125 μm fiber, units of 2 m
144	Length 50 μm (1 Byte)	Link length supported for 50/125 μm fiber, units of 1 m
145	Length 62.5 μm (1 Byte)	Link length supported for 62.5/125 μm fiber, units of 1 m
146	Length copper (1 Byte)	Link length supported for copper, units of 1 m
147	Device Tech (1 Byte)	Device technology
148-163	Vendor name (16 Bytes)	QSFP vendor name (ASCII)
164	Extended Transceiver (1 Byte)	Extended Transceiver Codes for InfiniBand [†]
165-167	Vendor OUI (3 Bytes)	QSFP vendor IEEE vendor company ID
168-183	Vendor PN (16 Bytes)	Part number provided by QSFP vendor (ASCII)
184-185	Vendor rev (2 Bytes)	Revision level for part number provided by vendor (ASCII)
186-187	Wavelength (2 Bytes)	Nominal laser wavelength (Wavelength = value / 20 in nm)
188-189	Wavelength Tolerance (2 Bytes)	Guaranteed range of laser wavelength (+/- value) from Nominal wavelength (Wavelength Tol. = value / 200 in nm)
190	Max Case Temp (1 Byte)	Maximum Case Temperature in Degrees C
191	CC_BASE (1 Byte)	Check code for Base ID fields (addresses 128-190)
192-195	Options (4 Bytes)	Rate Select, TX Disable, TX Fault, LOS
196-211	Vendor SN (16 Bytes)	Serial number provided by vendor (ASCII)
212-219	Date code (8 Bytes)	Vendor's manufacturing date code
220	Diagnostic Monitoring Type (1 Byte)	Indicates which type of diagnostic monitoring is implemented
221	Enhanced Options (1 Byte)	Indicates which optional enhanced features are implemented
222	Reserved (1 Byte)	Reserved
223	CC_EXT	Check code for the Extended ID Fields (addresses 192-222)
224-255	Vendor Specific (32 Bytes)	Vendor Specific EEPROM

Page02 is User EEPROM and its format decided by user.

The detail description of low memory and page00.page03 upper memory please see SFF-8436 document.

Technical Datasheet

Timing for Soft Control and Status Functions

Parameter	Symbol	Max	Unit	Conditions
Initialization Time	t_init	2000	ms	Time from power on1, hot plug or rising edge of Reset until the module is fully functional2
Reset Init Assert Time	t_reset_init	2	µs	A Reset is generated by a low level longer than the minimum reset pulse time present on the ResetL pin.
Serial Bus Hardware Ready Time	t_serial	2000	ms	Time from power on1 until module responds to data transmission over the 2-wire serial bus
Monitor Data Ready Time	t_data	2000	ms	Time from power on1 to data not ready, bit 0 of Byte 2, deasserted and IntL asserted
Reset Assert Time	t_reset	2000	ms	Time from rising edge on the ResetL pin until the module is fully functional2
LPMMode Assert Time	ton_LPMMode	100	µs	Time from assertion of LPMMode (Vin:LPMMode =Vih) until module power consumption enters lower Power Level
IntL Assert Time	ton_IntL	200	ms	Time from occurrence of condition triggering IntL until Vout:IntL = Vol
IntL Deassert Time	toff_IntL	500	µs	toff_IntL 500 µs Time from clear on read3 operation of associated flag until Vout:IntL = Voh. This includes deassert times for Rx LOS, Tx Fault and other flag bits.
Rx LOS Assert Time	ton_los	100	ms	Time from Rx LOS state to Rx LOS bit set and IntL asserted
Flag Assert Time	ton_flag	200	ms	Time from occurrence of condition triggering flag to associated flag bit set and IntL asserted
Mask Assert Time	ton_mask	100	ms	Time from mask bit set4 until associated IntL assertion is inhibited
Mask De-assert Time	toff_mask	100	ms	Time from mask bit cleared4 until associated IntL operation resumes
ModSelL Assert Time	ton_ModSelL	100	µs	Time from assertion of ModSelL until module responds to data transmission over the 2-wire serial bus
ModSelL Deassert Time	toff_ModSelL	100	µs	Time from deassertion of ModSelL until the module does not respond to data transmission over the 2-wire serial bus

Technical Datasheet

Power_override or Power-set Assert Time	ton_Pdown	100	ms	Time from P_Down bit set 4 until module power consumption enters lower Power Level
Power_override or Power-set De-assert Time	toff_Pdown	300	ms	Time from P_Down bit cleared 4 until the module is fully functional 3

Note:

1. Power on is defined as the instant when supply voltages reach and remain at or above the minimum specified value.
2. Fully functional is defined as IntL asserted due to data not ready bit, bit 0 byte 2 de-asserted.
3. Measured from falling clock edge after stop bit of read transaction.
4. Measured from falling clock edge after stop bit of write transaction.

Pin Assignment

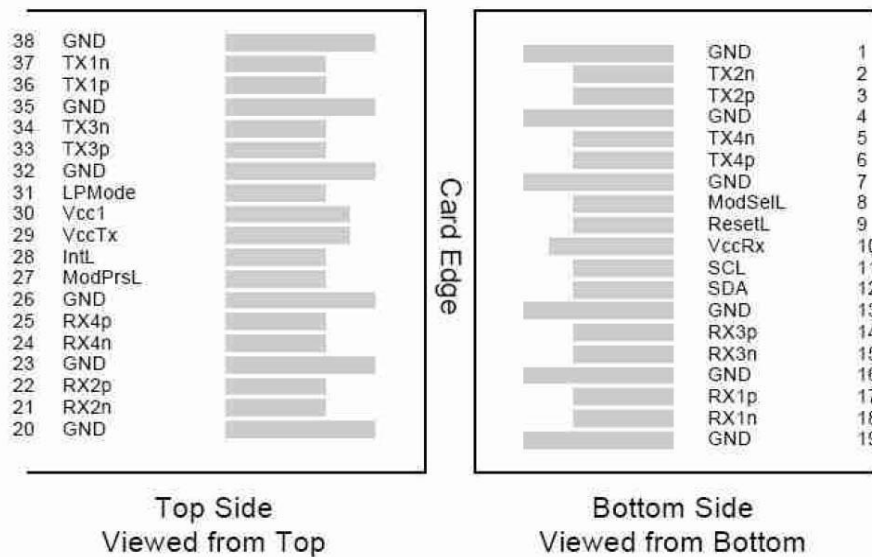

Diagram of Host Board Connector Block Pin Numbers and Name

Technical Datasheet

Pin Description

Pin	Logic	Symbol	Name/Description	Ref.
1		GND	Ground	1
2	CML-I	Tx2n	Transmitter Inverted Data Input	
3	CML-I	Tx2p	Transmitter Non-Inverted Data output	
4		GND	Ground	1
5	CML-I	Tx4n	Transmitter Inverted Data Output	
6	CML-I	Tx4p	Transmitter Non-Inverted Data Output	
7		GND	Ground	1
8	LVTTL-I	ModSelL	Module Select	
9	LVTTL-I	ResetL	Module Reset	
10		VccRx	+3.3V Power Supply Receiver	2
11	LVCMOS-I/O	SCL	2-Wire Serial Interface Clock	
12	LVCMOS-I/O	SDA	2-Wire Serial Interface Data	
13		GND	Ground	1
14	CML-O	Rx3p	Receiver Inverted Data Output	
15	CML-O	Rx3n	Receiver Non-Inverted Data Output	
16		GND	Ground	1
17	CML-O	Rx1p	Receiver Inverted Data Output	
18	CML-O	Rx1n	Receiver Non-Inverted Data Output	
19		GND	Ground	1
20		GND	Ground	1
21	CML-O	Rx2n	Receiver Inverted Data Output	
22	CML-O	Rx2p	Receiver Non-Inverted Data Output	
23		GND	Ground	1
24	CML-O	Rx4n	Receiver Inverted Data Output	
25	CML-O	Rx4p	Receiver Non-Inverted Data Output	
26		GND	Ground	1
27	LVTTL-O	ModPrsL	Module Present	

Technical Datasheet

28	LVTTL-O	IntL	Interrupt	
29		VccTx	+3.3V Power Supply Transmitter	2
30		Vcc1	+3.3V Power Supply	2
31	LVTTL-I	LPMODE	Low Power Mode	
32		GND	Ground	1
33	CML-I	Tx3p	Transmitter Inverted Data Output	
34	CML-I	Tx3n	Transmitter Non-Inverted Data Output	
35		GND	Ground	1
36	CML-I	Tx1p	Transmitter Inverted Data Output	
37	CML-I	Tx1n	Transmitter Non-Inverted Data Output	
38		GND	Ground	1

Notes:

1. GND is the symbol for single and supply (power) common for QSFP modules, all are common within the QSFP module and all module voltages are referenced to this potential otherwise noted. Connect these directly to the host board signal common ground plane. Laser output disabled on TDIS >2.0V or open, enabled on TDIS <0.8V.
2. VccRx, Vcc1 and VccTx are the receiver and transmitter power suppliers and shall be applied concurrently. Recommended host board power supply filtering is shown below. VccRx, Vcc1 and VccTx may be internally connected within the QSFP transceiver module in any combination. The connector pins are each rated for maximum current of 500mA.

Recommended Circuit

Technical Datasheet

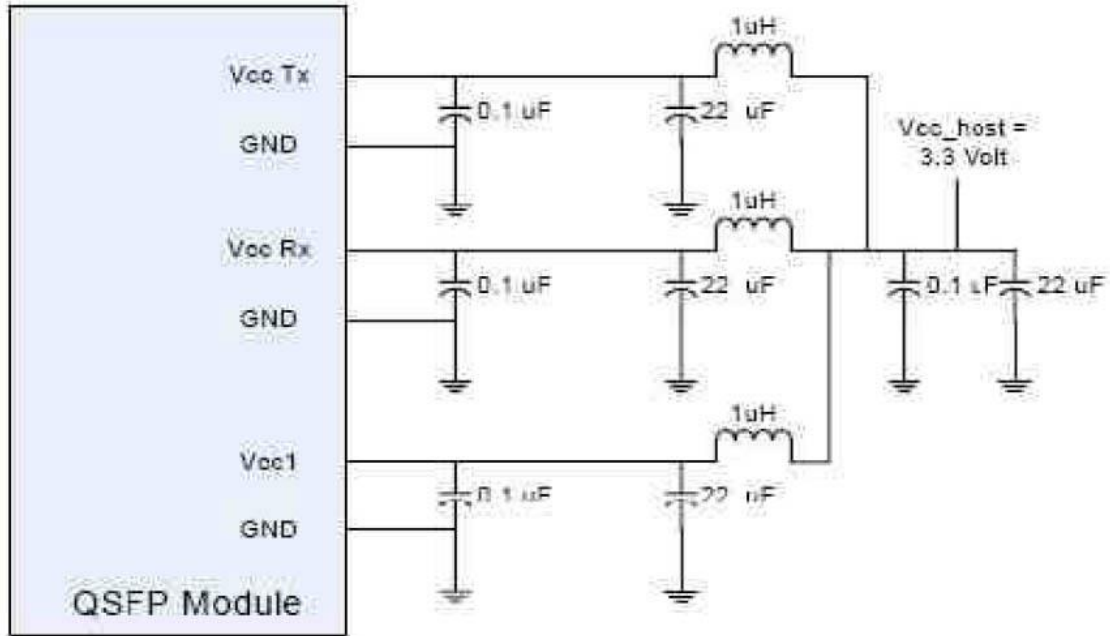

Mechanical Dimensions

