

THIS IS A C.A.D. GENERATED DRAWING
DO NOT MAKE MANUAL REVISIONS TO MASTER.

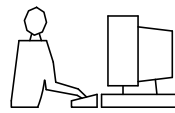

* UNLESS OTHERWISE SPECIFIED TOLERANCES
ON DECIMAL IS: ANGLE ±5°
UNIT: MM X. ±0.38
X.X ±0.25

BACKSHELL KIT INCLUDES:

- (2)BACKSHELL HALVES
- (2)4-40 THUMBSCREWS
- (2)HOUSING SCREWS & (2)NUTS
- (1)SET OF COMPRESSION INSERTS-VARIOUS SIZES
DIAMETERS:4mm(.157"),5mm(.197"),7mm(.276"),9mm(.351")

NOTE: 9 POSITION HAS ONLY 1 THUMBSCREW
(OPPOSITE CABLE ENTRY)

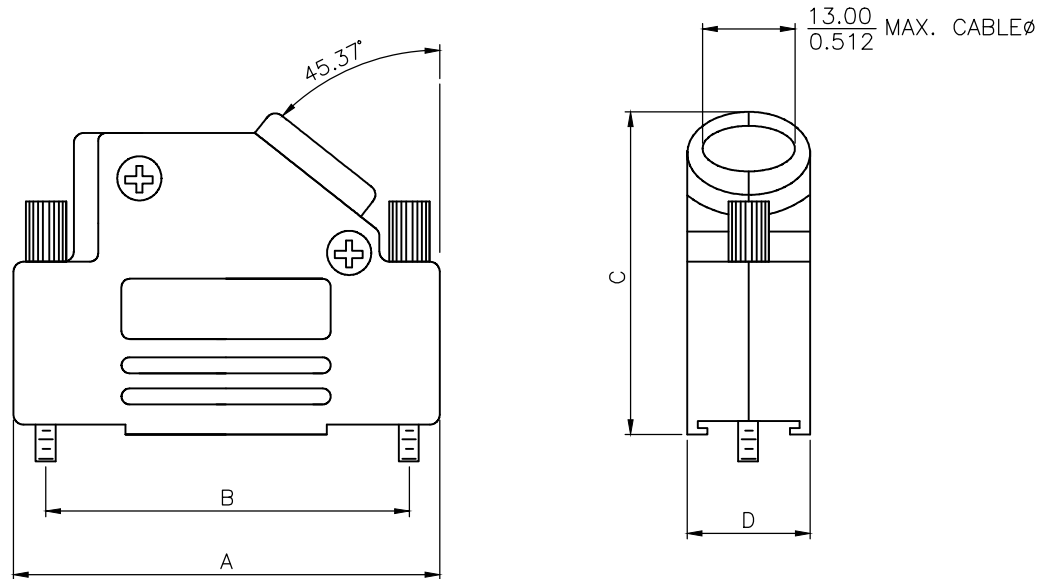

DIMENSIONS(mm/in)				
SIZE	A $\pm 1.70^{(+.067)}$ $\pm .50^{(-.02)}$	B $\pm .25$ $\pm .010$	C $\pm 2.40^{(+.094)}$ $\pm .50^{(-.02)}$	D $\pm .85^{(+.033)}$ $\pm .30^{(-.012)}$
9	31.00	24.99	36.30	15.00
	1.220	0.984	1.429	0.591
15	39.50	33.32	40.30	15.00
	1.555	1.312	1.587	0.591
25	53.20	47.04	40.30	15.00
	2.094	1.852	1.587	0.591
37	69.70	63.50	40.30	15.00
	2.744	2.500	1.587	0.591

ORDERING INFORMATON:

SIZE	P/N - KITTED	PRODUCT CODE
9-WAY	6560-0107-11	MHD45PPK-9-K
15-WAY	6560-0107-12	MHD45PPK-15-K
25-WAY	6560-0107-13	MHD45PPK-25-K
37-WAY	6560-0107-14	MHD45PPK-37-K

SIZE	P/N - BULK	PRODUCT CODE
9-WAY	6561-0107-11	MHD45PPK-9
15-WAY	6561-0107-12	MHD45PPK-15
25-WAY	6561-0107-13	MHD45PPK-25
37-WAY	6561-0107-14	MHD45PPK-37

PLASTIC: ABS UL 94-HB RATED
4-40 THUMBSCREWS: STEEL-BLACK OXIDE FINISH
HOOD SCREWS: STEEL-BLACK OXIDE FINISH
COMPRESSION INSERTS: ABS UL 94-HB RATED
NUTS: STEEL-BLACK OXIDE FINISH
OPERATING TEMP: -55°C TO+110°C

THESE DRAWINGS AND SPECIFICATIONS ARE THE PROPERTY OF MH CONNECTORS AND SHALL NOT BE REPRODUCED, COPIED OR USED AS THE BASIS FOR THE MANUFACTURE OR SALE OF APPARATUS WITHOUT WRITTEN PERMISSION.

DRAWN Johnny	DATE 11-24-15
APPROVED Victor Lin	DATE 11-24-15



THIS SERIES FULLY CONFORMS TO THE EUROPEAN UNION DIRECTIVES 2002/95/EC AND 2002/96/EC FOR RoHS COMPLIANCY.



**MH CONNECTORS ,
DIVISION OF EDAC**

SCALE 1 : 1	SHEET OF 1 OF 1	REV: 2.0
----------------	--------------------	-------------

DRAWING No
MHD45PPK SERIES

THIS IS A C.A.D. GENERATED DRAWING
DO NOT MAKE MANUAL REVISIONS TO MASTER.

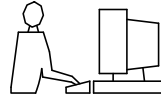

* UNLESS OTHERWISE SPECIFIED TOLERANCES
ON DECIMAL IS: ANGLE $\pm 1^\circ$
.X ± 0.25
.XX ± 0.15

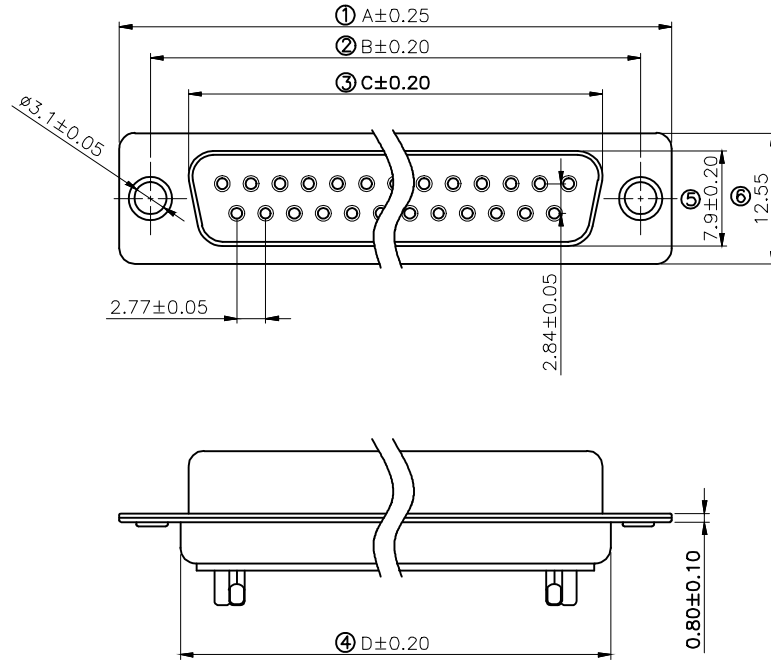

Remark:

1.SPECIFICATION:

Rated voltage:250V
Rates current:5AMP
Contact resistance:20M Ω MAX
Insulation resistance:1000M Ω MIN.at 500V DC
Withstand voltage:500V Per mintute
Temperature range:-55 -105 $^\circ$ C

2.MATERIAL:

Plastic:PBT+30% G.F (UL94V-0) BLACK
Terminal:brass ,tin-gold plated
Spcc shell:Spcc front shell is nickel plated back shell is nickel plated

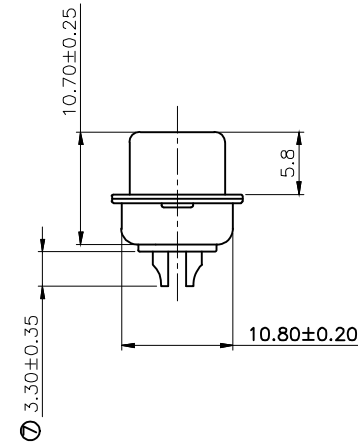

PN	PIN	A	B	C	D
MHDB9SS	09	30.88	24.88	16.17	18.94
MHDB15SS	15	39.20	33.30	24.66	27.50
MHDB25SS	25	53.02	47.04	38.38	41.20
MHDB37SS	37	69.40	63.50	55.20	57.40

THESE DRAWINGS AND SPECIFICATIONS ARE THE PROPERTY OF MH CONNECTORS AND SHALL NOT BE REPRODUCED, COPIED OR USED AS THE BASIS FOR THE MANUFACTURE OR SALE OF APPARATUS WITHOUT WRITTEN PERMISSION.

DRAWN
Iven Ou
DATE
08-31-22

APPROVED
DATE

SCALE
1 : 1
SHEET OF
1 OF 1
REV:
3.0

DRAWING No
MHDB SS



THIS SERIES FULLY CONFORMS TO THE EUROPEAN UNION DIRECTIVES 2002/95/EC AND 2002/96/EC FOR RoHS COMPLIANCY.



MH CONNECTORS ,
DIVISION OF EDAC