

Click [here](#) to ask an associate for production status of specific part numbers.

MAX40263

1.8V, 15MHz, Low-Offset, Low-Power, Rail-to-Rail Dual Op-Amp with Individual Shutdown

General Description

The MAX40263 is a dual-channel operational amplifier with two channels that can be disabled separately with two individual pins.

The MAX40263 offers a unique combination of high-speed, precision, and low-voltage operation, making it ideally suited for a large number of signal-processing functions such as filtering and amplification of signals in portable and industrial equipment.

The MAX40263's rail-to-rail input/outputs and low noise guarantee maximum dynamic range in demanding applications such as 12- to 14-bit SAR ADC drivers. Unlike traditional rail-to-rail input structures, input crossover distortion is absent due to an optimized input stage with an ultra-quiet charge pump. The input offset voltage is as low as 50 μ V due to the autocalibration performed during power-up. The device also includes a fast-power-on shutdown mode for further power savings.

The MAX40263 operates from a wide supply range of 1.8V to 5.5V over the -40°C to +125°C temperature range and consumes only 750 μ A (typ) supply current per channel. It is available in a tiny, 10-pin QFN package.

The MAX40263 is an extension of the MAX44259/60/61/63 and MAX40110/11 families with individual shutdown pins for separate channels.

Applications

- Notebooks
- 3G/4G Handsets
- Portable Medical Instruments
- Battery-Operated Devices
- Analog-to-Digital Converter Buffers
- Transimpedance Amplifiers
- General-Purpose Signal Processing

Benefits and Features

- Wide Supply Range from 1.8V to 5.5V over the -40°C to +125°C Range
- Low 50 μ V (Max) Input Offset Voltage with Power-On Autocalibration at +25°C
- 15 MHz Unity-Gain Bandwidth
- Low 12.7nV/ $\sqrt{\text{Hz}}$ Input Voltage-Noise Density
- 750 μ A Quiescent Current per Channel
- Rail-to-Rail Inputs and Outputs
- <1.5pA Low Input Bias Current at +25°C
- Power-Saving Shutdown Mode
- Separate Shutdown for Each Channel
- Low 105dB Total Harmonic Distortion
- No Phase Reversal in Overdrive Conditions

Typical Application Circuits

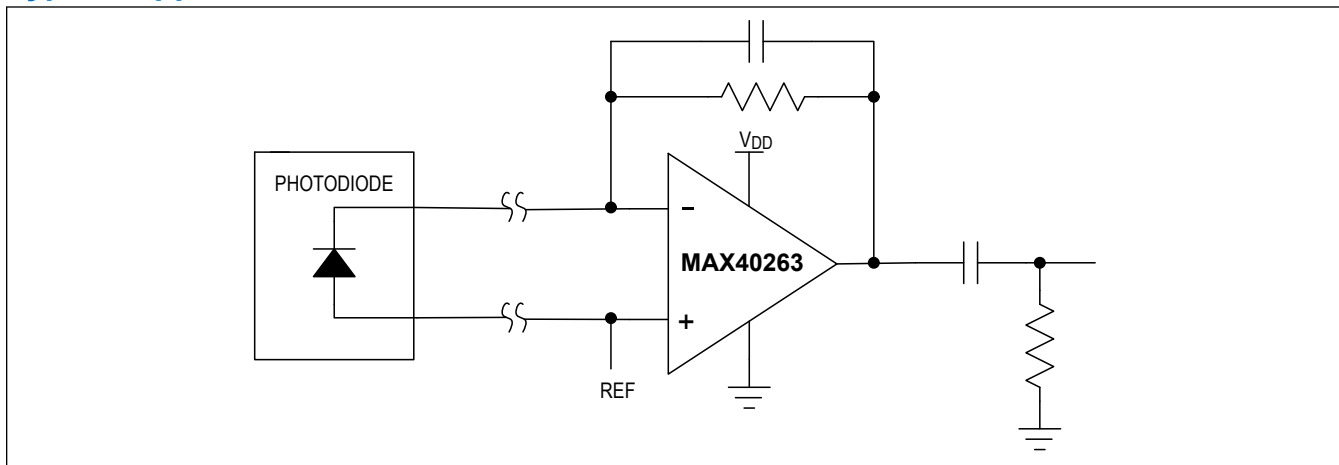

TABLE OF CONTENTS

| | |
|---|----|
| General Description | 1 |
| Applications | 1 |
| Benefits and Features | 1 |
| Typical Application Circuits | 2 |
| Absolute Maximum Ratings | 5 |
| Package Information | 5 |
| 10-Ultra TQFN | 5 |
| Electrical Characteristics | 7 |
| Typical Operating Characteristics | 10 |
| Pin Configuration | 14 |
| Pin Description | 14 |
| Detailed Description | 15 |
| Crossover Distortion | 15 |
| Applications Information | 16 |
| Power-Up Autotrim | 16 |
| Shutdown Operation | 16 |
| Rail-to-Rail Input/Output | 16 |
| Input Bias Current | 17 |
| Typical Application Circuits | 17 |
| Sallen-Key Filter | 17 |
| Ordering Information | 17 |
| Revision History | 18 |

MAX40263 1.8V, 15MHz, Low-Offset, Low-Power, Rail-to-Rail
Dual Op-Amp with Individual Shutdown

LIST OF FIGURES

Figure 1. Comparing the Input Structure of the MAX40263 to Standard Op Amps. 15
Figure 2. Crossover Distortion of Typical Amplifiers 15
Figure 3. Shutdown Input Operation 16

Absolute Maximum Ratings

| | | | |
|---|---------------------------------|---|---|
| Supply Voltage (V_{DD} to V_{SS}) | -0.3V to +6V | Continuous Power Dissipation ($T_A = +70^\circ\text{C}$) | |
| SHDNA, SHDNB to V_{SS} | -0.3V to +6V | (derate 9mW/ $^\circ\text{C}$ above $+70^\circ\text{C}$) | 722 mW |
| INA+, INA-, INB+, INB- to V_{SS} | -0.3V to $V_{DD} + 0.3\text{V}$ | Operating Temperature Range | -40°C to $+125^\circ\text{C}$ |
| OUTA, OUTB to V_{SS} | -0.3V to $V_{DD} + 0.3\text{V}$ | Junction Temperature | $+150^\circ\text{C}$ |
| Output Short-Circuit Duration to V_{DD} or V_{SS} | Continuous | Storage Temperature Range | -65°C to $+150^\circ\text{C}$ |
| Continuous Input Current (any pins) | $\pm 20\text{mA}$ | Soldering Temperature (reflow) | $+300^\circ\text{C}$ |
| Differential Input Voltage | $\pm 6\text{V}$ | | |

Stresses beyond those listed under "Absolute Maximum Ratings" may cause permanent damage to the device. These are stress ratings only, and functional operation of the device at these or any other conditions beyond those indicated in the operational sections of the specifications is not implied. Exposure to absolute maximum rating conditions for extended periods may affect device reliability.

Package Information

10-Ultra TQFN

| | |
|---------------------------------------|---------------------------------|
| Package Code | V101A2CN+1 |
| Outline Number | 21-0610 |
| Land Pattern Number | 90-0386 |
| Thermal Resistance, Four-Layer Board: | |
| Junction to Ambient (θ_{JA}) | 110.8 $^\circ\text{C}/\text{W}$ |
| Junction to Case (θ_{JC}) | 62.1 $^\circ\text{C}/\text{W}$ |

For the latest package outline information and land patterns (footprints), go to www.maximintegrated.com/packages. Note that a "+", "#", or "-" in the package code indicates RoHS status only. Package drawings may show a different suffix character, but the drawing pertains to the package regardless of RoHS status.

Package thermal resistances were obtained using the method described in JEDEC specification JESD51-7, using a four-layer board. For detailed information on package thermal considerations, refer to www.maximintegrated.com/thermal-tutorial.

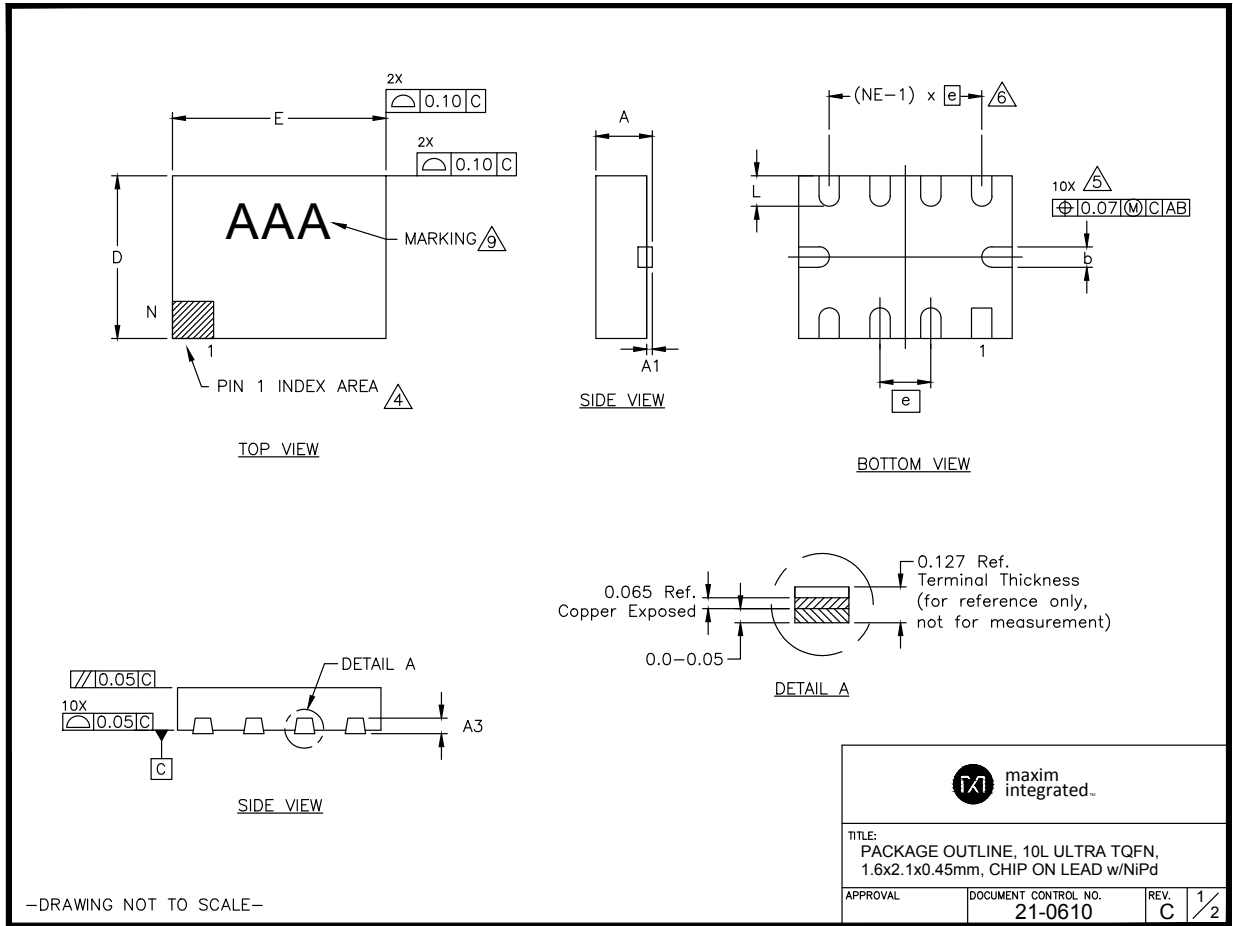

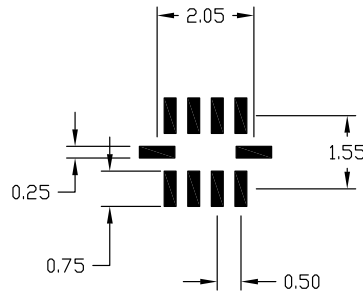

NOTES:

1. REFERENCE PKG. OUTLINE: 21-0610.
2. LAND PATTERN COMPLIES TO: IPC7351A.
3. TOLERANCE: +/- 0.02 mm.
4. ALL DIMENSIONS APPLY TO BOTH LEADED (-) AND PbFREE (+) PKG. CODES.
5. ALL DIMENSIONS IN MM.

-DRAWING NOT TO SCALE-

MAXIM

TITLE:
PACKAGE LAND PATTERN,
[V101A2CN+1]

| | | |
|----------|---------------------------------|------------|
| APPROVAL | DOCUMENT CONTROL NO. 90-0386 | REV. A 1/1 |
|----------|---------------------------------|------------|

This document (including dimensions, notes & specs) is a recommendation based on typical circuit board manufacturing parameters. Since land pattern design depend on many factors unknown to Maxim (eg. user's board manufacturing specs), user must determine suitability for use. This document is subject to change without notice. Contact technical support at <http://www.maxim-ic.com/support> for further questions.

Electrical Characteristics

($V_{DD} = 3.3V$, $V_{SS} = 0V$, $V_{IN+} = V_{IN-} = V_{DD}/2$, $R_{LOAD} = 10k\Omega$ to $V_{DD}/2$, $V_{SHDN} = V_{DD}$, $T_A = -40^{\circ}C$ to $+125^{\circ}C$, unless otherwise noted. Typical values are at $+25^{\circ}C$.) (Note 1)

| PARAMETER | SYMBOL | CONDITIONS | | MIN | TYP | MAX | UNITS |
|------------------------------|------------|---------------------------------|-----------------------------|-----|------|------|---------|
| POWER SUPPLY | | | | | | | |
| Supply Voltage Range | V_{DD} | Guaranteed by PSRR | | 1.8 | | 5.5 | V |
| Power-Supply Rejection Ratio | PSRR | $V_{CM} = V_{DD}/2$ | | 76 | 95 | | dB |
| Quiescent Current | I_{DD} | Only one op-amp channel enabled | $R_{LOAD} = \text{no load}$ | | 750 | 1300 | μA |
| | | Both op-amp channels enabled | $R_{LOAD} = \text{no load}$ | | 1300 | 2200 | |
| Shutdown Supply Current | I_{SHDN} | | | | | 1 | μA |

Electrical Characteristics (continued)

($V_{DD} = 3.3V$, $V_{SS} = 0V$, $V_{IN+} = V_{IN-} = V_{DD}/2$, $R_{LOAD} = 10k\Omega$ to $V_{DD}/2$, $\overline{V_{SHDN}} = V_{DD}$, $T_A = -40^\circ C$ to $+125^\circ C$, unless otherwise noted. Typical values are at $+25^\circ C$.) (Note 1)

| PARAMETER | SYMBOL | CONDITIONS | | MIN | TYP | MAX | UNITS | |
|-------------------------------------|-----------------------|---|---|----------------|-----------|----------------|------------------|------|
| Shutdown Input Low | V_{IL} | | | | | 0.5 | V | |
| Shutdown Input High | V_{IH} | | | 1.3 | | | V | |
| Output Leakage Current in Shutdown | | | | | 100 | | pA | |
| Shutdown Input Bias Current | I_{IL}/I_{IH} | | | | | 1 | μA | |
| Shutdown Turn-On Time | $\overline{t_{SHDN}}$ | $T_A = +25^\circ C$ (Note 2) | One channel recovers after its own shutdown | | | 9 | μs | |
| | | | Both recover after a complete shutdown | | 14.4 | 18.9 | | |
| | | $-40^\circ C < T_A < +125^\circ C$ (Note 2) | One channel recovers after its own shutdown | | | | | 12 |
| | | | Both recover after a complete shutdown | | | | | 26.7 |
| Power-Up Time | t_{ON} | Includes power-on VOS self-calibration | $T_A = +25^\circ C$ (Note 2) | | 9.7 | 15.2 | ms | |
| | | | $-40^\circ C < T_A < +125^\circ C$ (Note 2) | | | 18.4 | | |
| DC CHARACTERISTICS | | | | | | | | |
| Input Common-Mode Range | V_{CM} | Guaranteed by CMRR test | | $V_{SS} - 0.1$ | | $V_{DD} + 0.1$ | V | |
| Common-Mode Rejection Ratio | CMRR | $V_{CM} = V_{SS} - 0.1V$ to $V_{DD} + 0.1V$ | | 75 | 90 | | dB | |
| Input Offset Voltage (Note 2) | V_{OS} | $T_A = +25^\circ C$ (Note 3) | | | 10 | 50 | μV | |
| | | $-40^\circ C \leq T_A \leq +125^\circ C$ (Note 4) | | | | 100 | | |
| | | $-40^\circ C \leq T_A \leq +125^\circ C$ (Note 5) | | | | 600 | | |
| Input Offset Voltage Drift (Note 2) | $TC V_{OS}$ | | | | 1 | 6 | $\mu V/^\circ C$ | |
| Input Bias Current (Note 2) | I_B | $T_A = +25^\circ C$ | | | 0.01 | 1.5 | pA | |
| | | $-40^\circ C < T_A < +85^\circ C$ | | | | 10 | | |
| | | $-40^\circ C < T_A < +125^\circ C$ | | | | 200 | | |
| Input Resistance | R_{IN} | Common-Mode | $V_{CM} = -0.1V$ to $(V_{DD} + 0.1V)$ | | 10^{11} | | Ω | |
| | | Differential | | | 10^{12} | | | |
| Open-Loop Gain | A_{VOL} | $400mV \leq V_{OUT} \leq V_{DD} - 400mV$, $R_{LOAD} = 10k\Omega$ | | 97 | 115 | | dB | |
| | | $400mV \leq V_{OUT} \leq V_{DD} - 400mV$, $R_{LOAD} = 600\Omega$ | | 86 | 100 | | | |
| Output Short-Circuit Current | | To V_{DD} or V_{SS} | | | 50 | | mA | |

Electrical Characteristics (continued)

($V_{DD} = 3.3V$, $V_{SS} = 0V$, $V_{IN+} = V_{IN-} = V_{DD}/2$, $R_{LOAD} = 10k\Omega$ to $V_{DD}/2$, $\overline{V_{SHDN}} = V_{DD}$, $T_A = -40^{\circ}C$ to $+125^{\circ}C$, unless otherwise noted. Typical values are at $+25^{\circ}C$.) (Note 1)

| PARAMETER | SYMBOL | CONDITIONS | | MIN | TYP | MAX | UNITS |
|----------------------------------|------------|---|--------------------------------------|-----|------|-----|----------------|
| Output Voltage Low | V_{OL} | $V_{OUT} - V_{SS}$ | $R_{LOAD} = 10k\Omega$ to $V_{DD}/2$ | | | 20 | mV |
| | | | $R_{LOAD} = 600\Omega$ to $V_{DD}/2$ | | | 50 | |
| Output Voltage High | V_{OH} | $V_{DD} - V_{OUT}$ | $R_{LOAD} = 10k\Omega$ to $V_{DD}/2$ | | | 10 | mV |
| | | | $R_{LOAD} = 600\Omega$ to $V_{DD}/2$ | | | 50 | |
| AC CHARACTERISTICS | | | | | | | |
| Input Voltage Noise Density | e_n | $f = 10kHz$ | | | 12.7 | | nV/\sqrt{Hz} |
| Input Voltage Noise | | $0.1Hz \leq f \leq 10Hz$ | | | 10 | | μV_{P-P} |
| Input Capacitance | C_{IN} | | | | 2.5 | | pF |
| Gain-Bandwidth Product | GBW | | | | 15 | | MHz |
| Slew Rate | SR | $A_V = 1V/V$, $V_{OUT} = 2V_{P-P}$, 10% to 90% | | | 7 | | $V/\mu s$ |
| Capacitive Loading | C_{LOAD} | No sustained oscillation, $A_V = 1V/V$ | | | 300 | | pF |
| Total Harmonic Distortion +Noise | THD+N | $V_{OUT} = 2V_{P-P}$, $A_V = 1V/V$, $R_{LOAD} = 10k\Omega$ | $f = 10kHz$ | | -105 | | dB |
| Settling Time | | T_o 0.01%, $V_{OUT} = 2V_{P-P}$, $A_V = 1V/V$, $C_{LOAD} = 30pF$ | | | 1.7 | | μs |
| Output Transient Recovery Time | | $\Delta V_{OUT} = 0.2V$, $V_{DD} = 3.3V$, $A_V = 1V/V$, $R_S = 20\Omega$, $C_{LOAD} = 1nF$ | | | 1 | | μs |

Note 1: All devices are 100% production tested at $T_A = +25^{\circ}C$. Specifications over temperature are guaranteed by design.

Note 2: Guaranteed by design.

Note 3: At $+25^{\circ}C$, upon power up and after calibration.

Note 4: For any temperature values between $-40^{\circ}C$ to $+125^{\circ}C$, upon power up and after calibration.

Note 5: For any temperature values between $-40^{\circ}C$ and $+125^{\circ}C$, it indicates the maximum drift from the power-up initial calibrated value.

Typical Operating Characteristics

($T_A = +25^\circ\text{C}$, unless otherwise noted.)

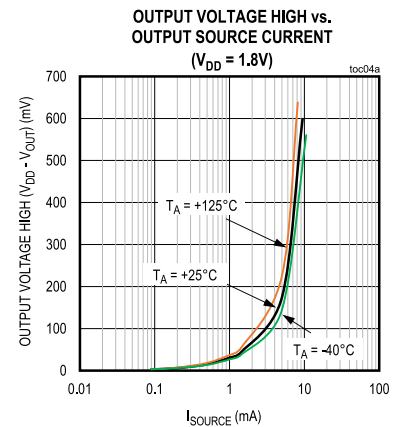
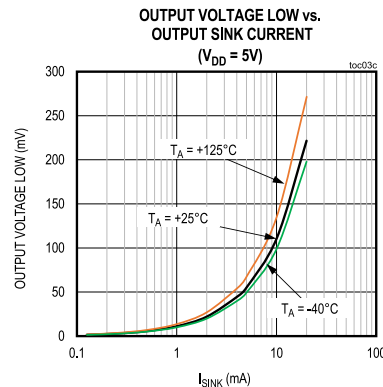
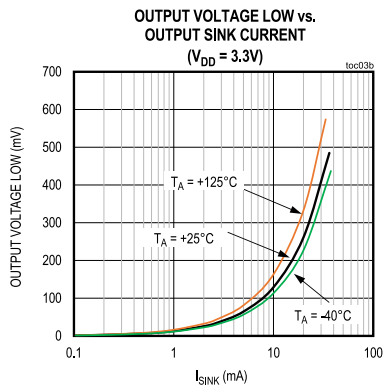
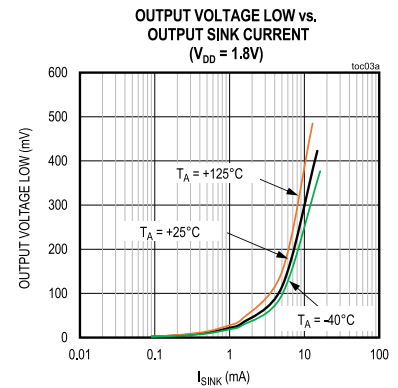
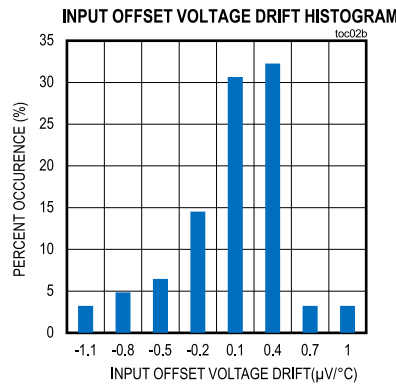
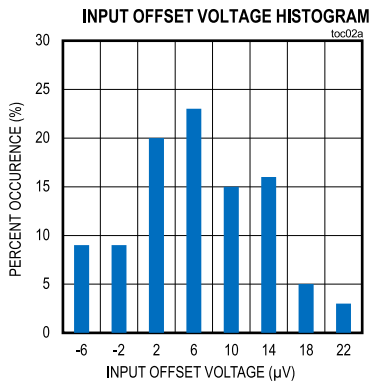
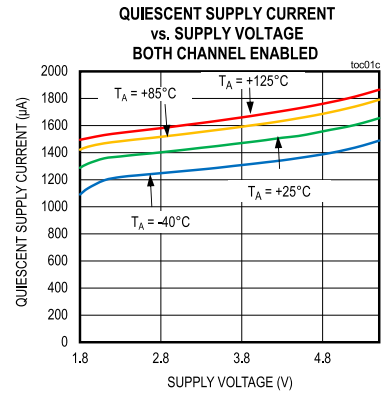
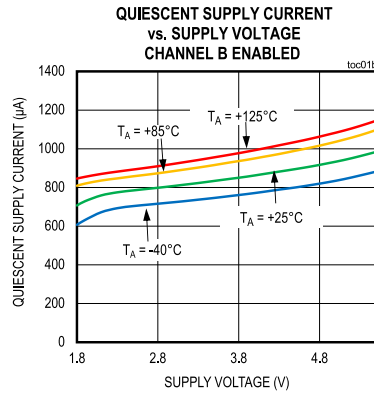
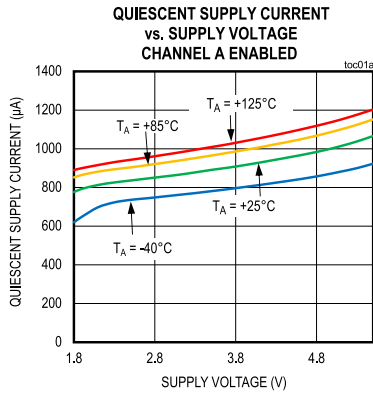

Typical Operating Characteristics (continued)

($T_A = +25^\circ\text{C}$, unless otherwise noted.)

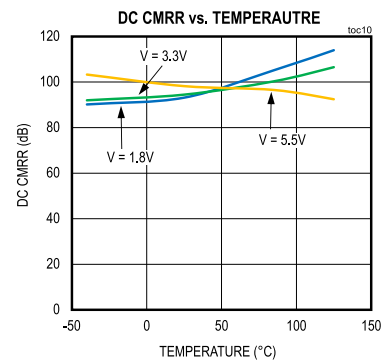
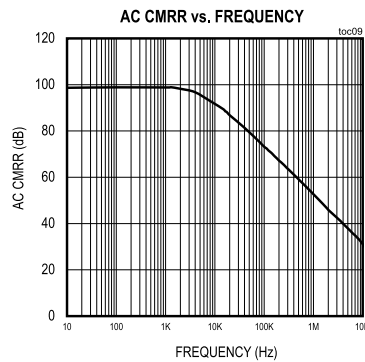
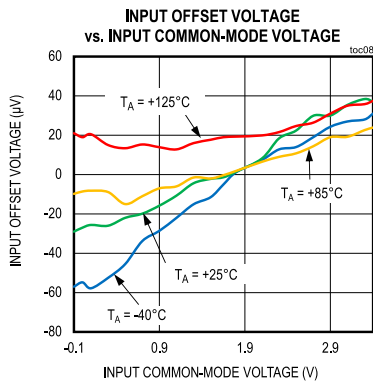
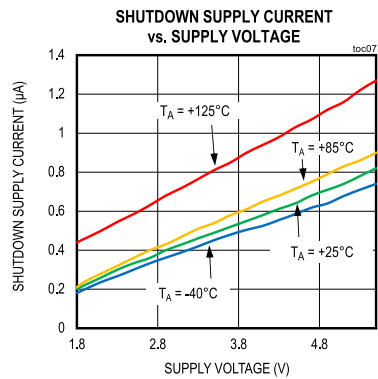
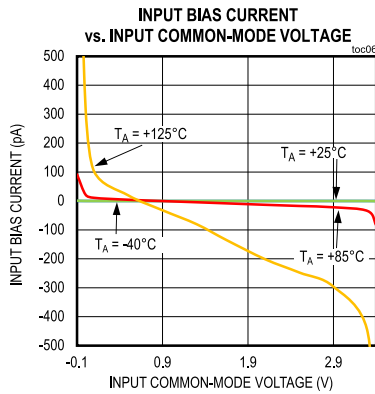
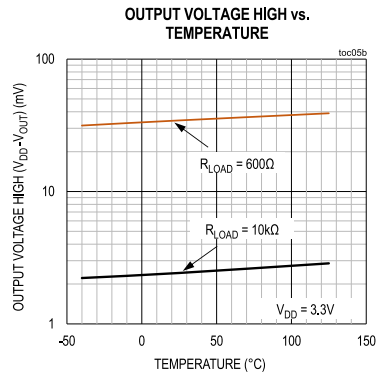
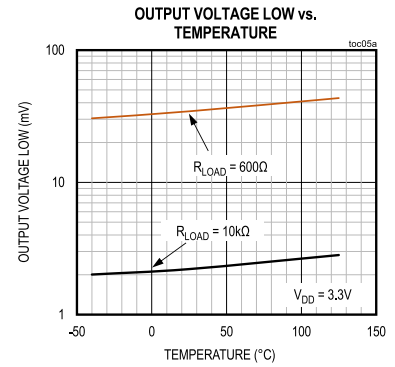
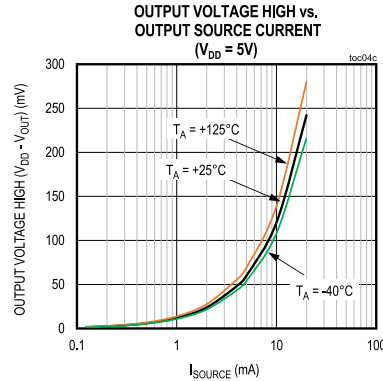
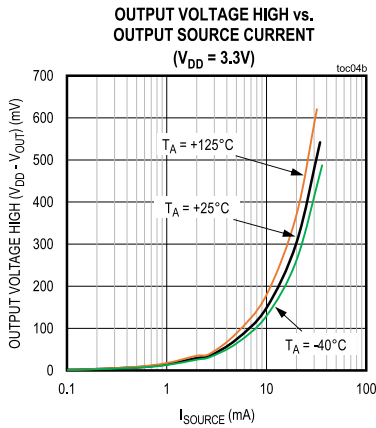

Typical Operating Characteristics (continued)

(T_A = +25°C, unless otherwise noted.)

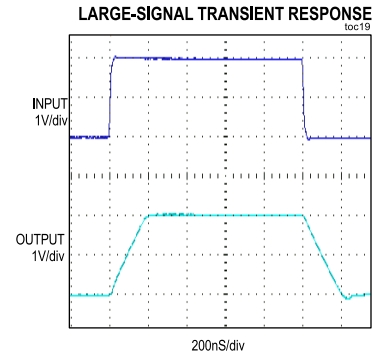
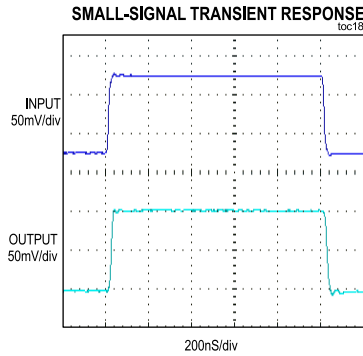
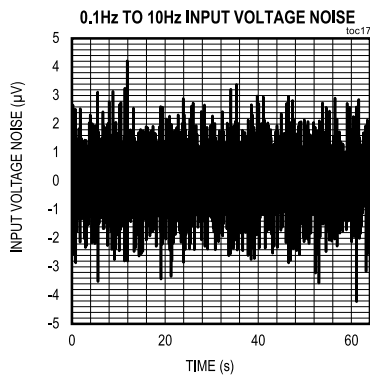
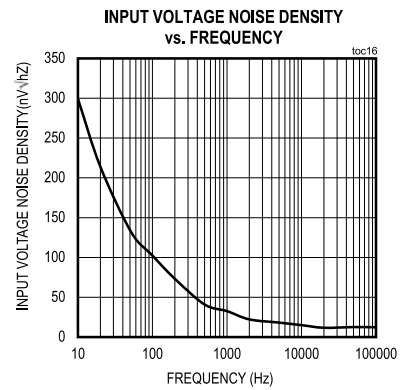
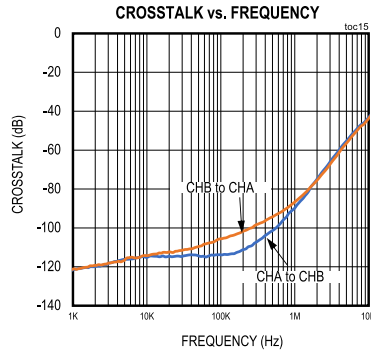
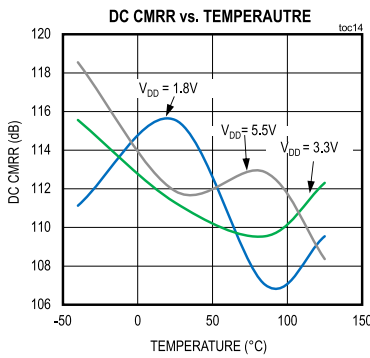
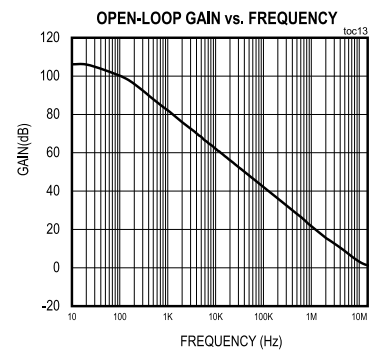
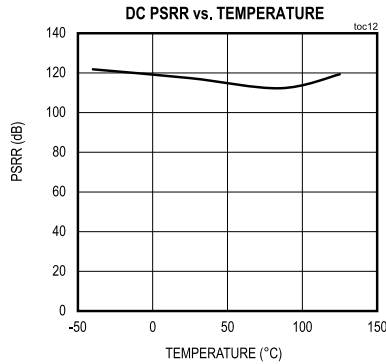
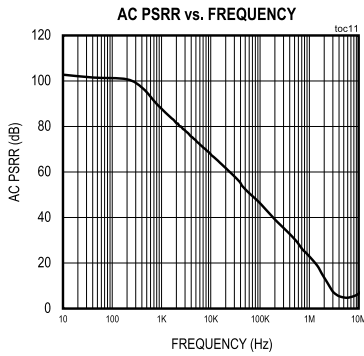

Typical Operating Characteristics (continued)

($T_A = +25^\circ\text{C}$, unless otherwise noted.)

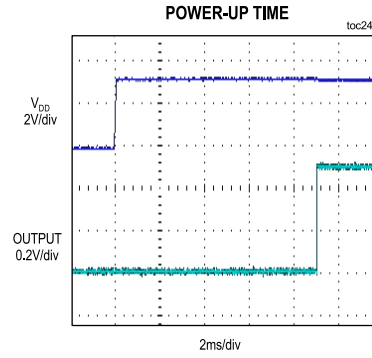
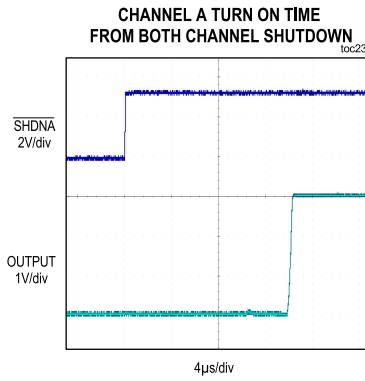
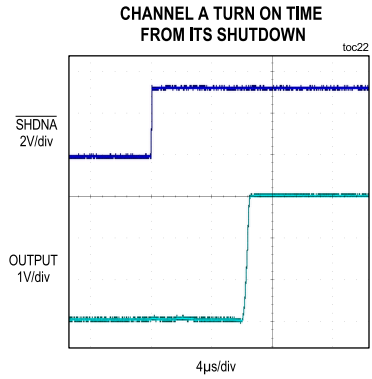
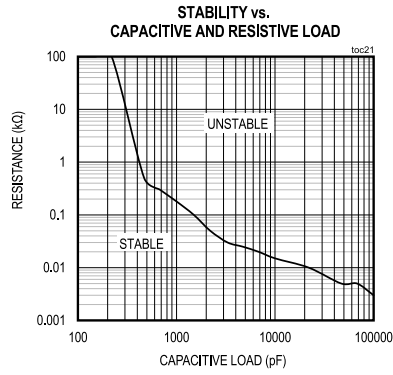
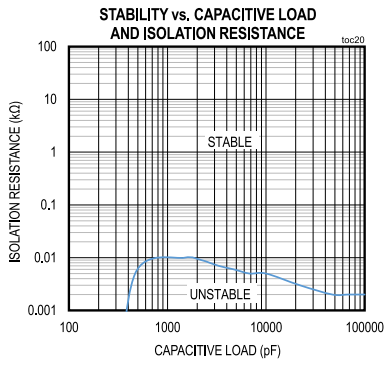

Pin Configuration

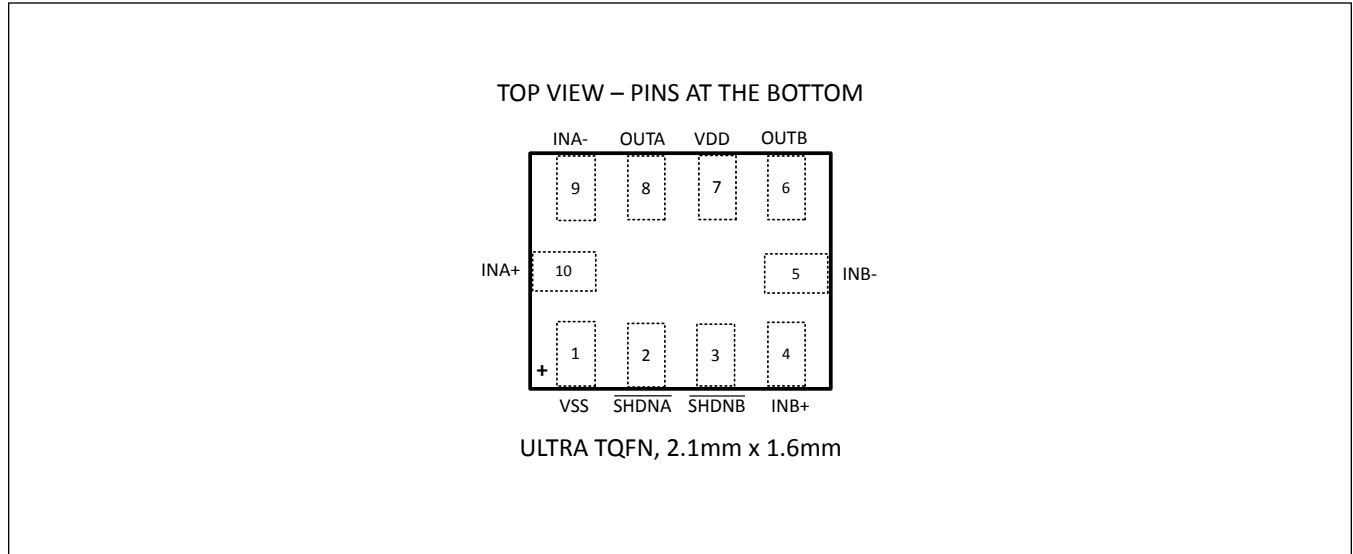

Pin Description

| PIN | NAME | FUNCTION | TYPE |
|-----|---------------------------|--|---------------|
| 1 | VSS | Negative Supply Voltage. Connect to the ground return of the V_{DD} supply. | Power |
| 7 | VDD | Positive Supply Voltage | Power |
| 2 | $\overline{\text{SHDNA}}$ | Active-Low Shutdown Input for Channel A. Connect to V_{DD} for normal operation. | Analog Input |
| 8 | OUTA | Output for Channel A | Analog Output |
| 10 | INA+ | Positive Input for Channel A | Analog Input |
| 9 | INA- | Negative Input for Channel A | Analog Input |
| 3 | $\overline{\text{SHDNB}}$ | Active-Low Shutdown Input for Channel B. Connect to V_{DD} for normal operation. | Analog Input |
| 6 | OUTB | Output for Channel B | Analog Output |
| 4 | INB+ | Positive Input for Channel B | Analog Input |
| 5 | INB- | Negative Input for Channel B | Analog Input |

Detailed Description

The MAX40263 is a high-speed, low-power dual-channel op-amp ideal for signal processing applications due to the device's high precision and low-noise CMOS inputs. The device self-calibrates on power-up to eliminate the effects of temperature and power supply variation. Each channel of MAX40263 can enter into low-power shutdown mode separately and recover in 30µs.

Crossover Distortion

The device features a low-noise integrated charge pump that creates an internal voltage rail 1V above V_{DD} , which powers the input differential pair of PMOS transistors as shown in [Figure 1](#). This unique architecture eliminates crossover distortion common in traditional CMOS input architecture ([Figure 2](#)), especially when used in a noninverting configuration such as Sallen-Key filters.

The charge pump operating frequency lies well above the unity-gain frequency of the amplifier. Because of its high-frequency operation and ultra-quiet circuitry, the charge pump generates little noise, does not require external components, and is entirely transparent to the user.

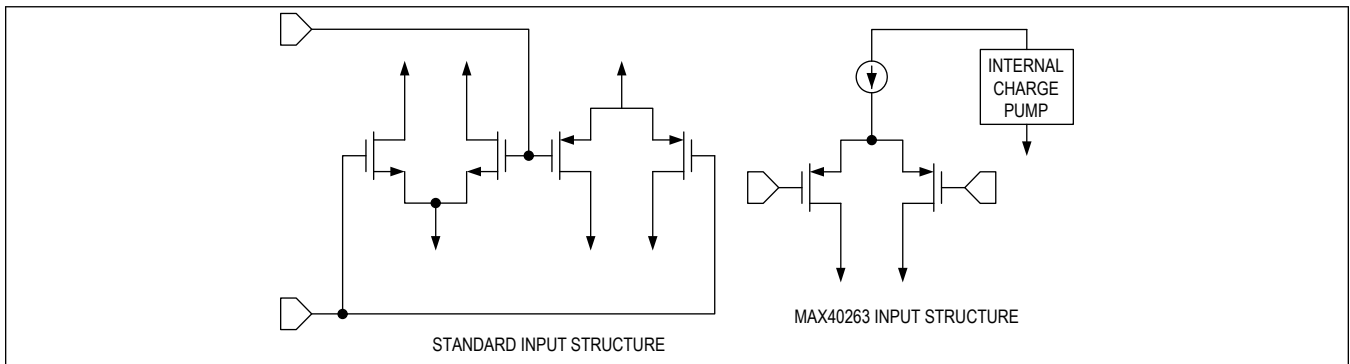

Figure 1. Comparing the Input Structure of the MAX40263 to Standard Op Amps

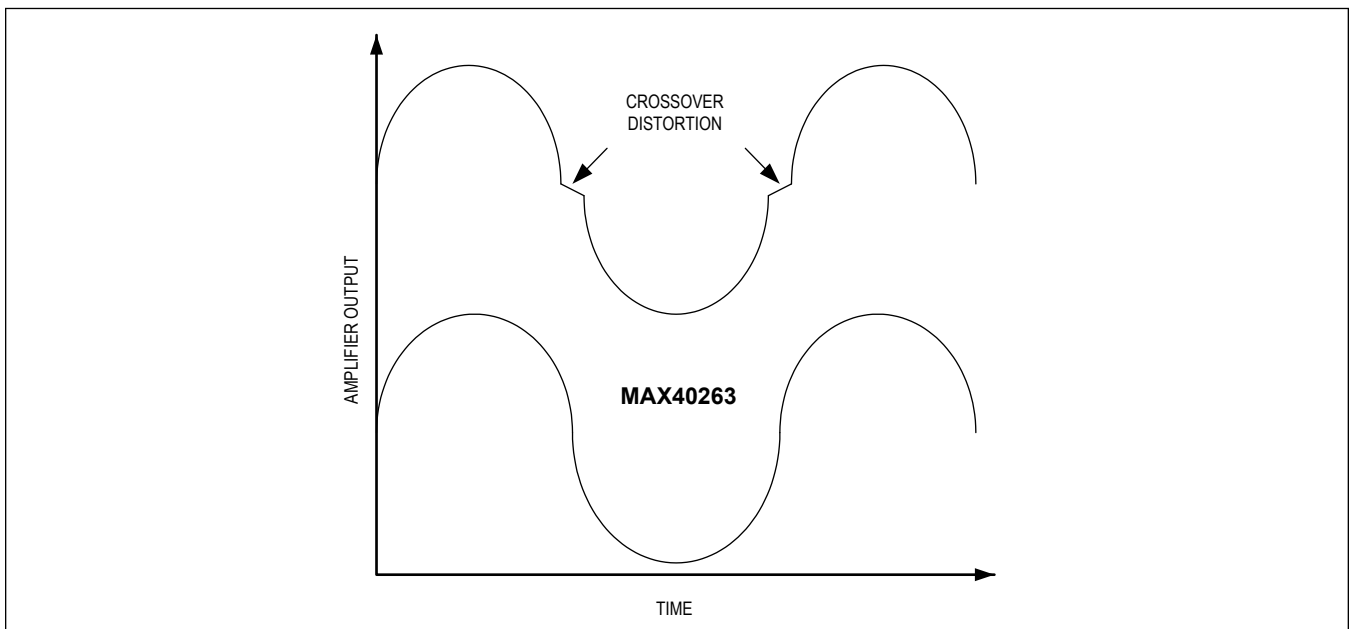

Figure 2. Crossover Distortion of Typical Amplifiers

Applications Information

Power-Up Autotrim

The MAX40263 features an automatic trim that self-calibrates the input offset voltage (V_{OS}) to less than $50\mu\text{V}$ on power-up. This self-calibration feature allows the device to eliminate input offset voltage effects due to power supply and operating temperature variation simply by cycling its power.

The device power-up speed should be fast to avoid the case when the self-calibration is triggered before the supply settles. Such a wrong condition would give an undesired large offset. To achieve targeted low V_{OS} values, it is recommended to either (a) use a power supply with a fast slew rate (power supply settles in $<10\text{ms}$), or (b) power up the chip in the shutdown mode ($\overline{\text{SHDNA}} = \overline{\text{SHDNB}} = \text{low}$) and enable the chip ($\overline{\text{SHDNA}} = \overline{\text{SHDNB}} = \text{high}$) after the supply settles.

Shutdown Operation

The MAX40263 is a dual channel op-amp, and each channel of MAX40263 can enter into low-power shutdown mode separately by pulling down $\overline{\text{SHDNA}}$ or $\overline{\text{SHDNB}}$.

Shutdown mode puts both inputs and outputs into high impedance and substantially lowers the quiescent current. Putting the output into high impedance allows multiple outputs to be multiplexed onto a single output line without the additional external buffers. The device does not self-calibrate when exiting shutdown mode and retains its power-up trim settings. [Figure 3](#) shows how the device recovers from shutdown in less than $30\mu\text{s}$.

The shutdown logic levels of the device are independent of supply, allowing the shutdown feature of the device to operate off a 1.8V or 3.3V microcontroller, regardless of supply voltage.

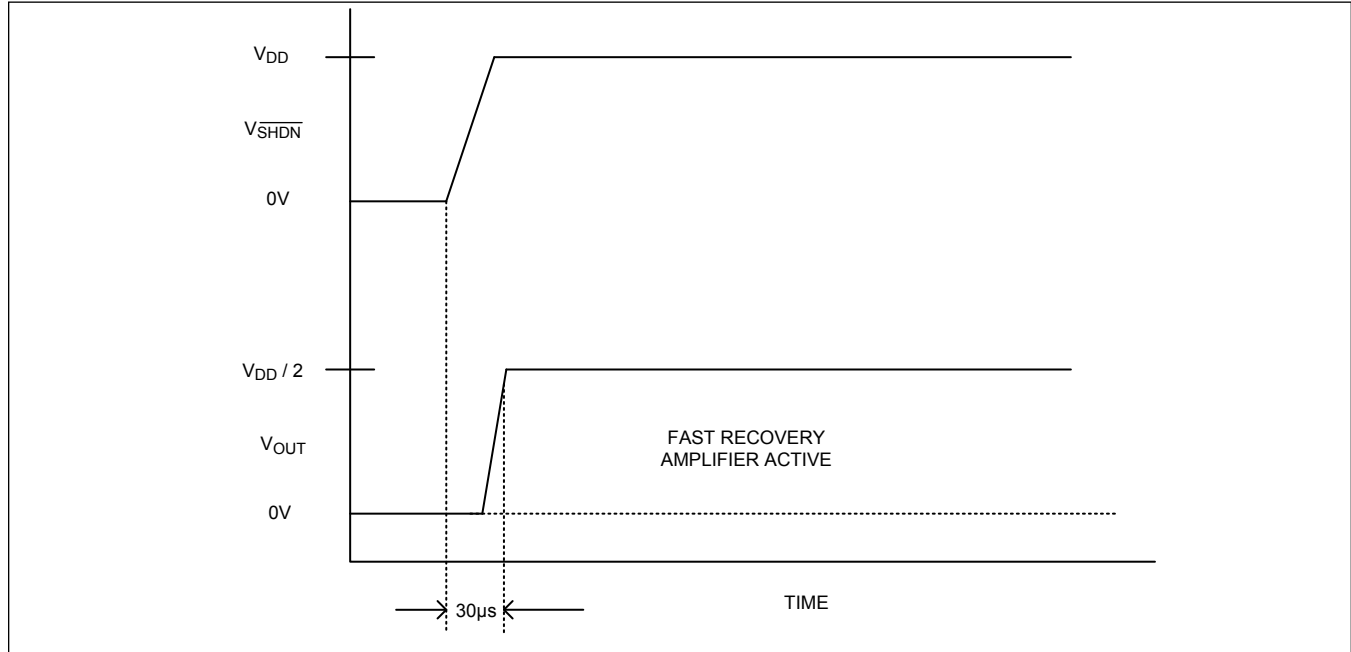

Figure 3. Shutdown Input Operation

Rail-to-Rail Input/Output

The input voltage range of the device extends 100mV above V_{DD} and below V_{SS} . The wide input common mode voltage range allows the op amp to be used as a buffer and as a differential amplifier in a variety of signal processing applications. Output voltage high/low is only 50mV above V_{SS} and below V_{DD} , allowing maximum dynamic range in single-supply

applications. The high output current and capacitance drive capability of the device make it ideal as an ADC driver and a line driver.

Input Bias Current

The MAX40263 features a high-impedance CMOS input stage and a specialized ESD structure that allows low input bias current operation at low-input, common-mode voltages. Low-input bias current is useful when interfacing with high-impedance sensors. It is also beneficial for designing transimpedance amplifiers for photodiode sensors. This makes the device ideal for ground referenced medical and industrial sensor applications.

Typical Application Circuits

Sallen-Key Filter

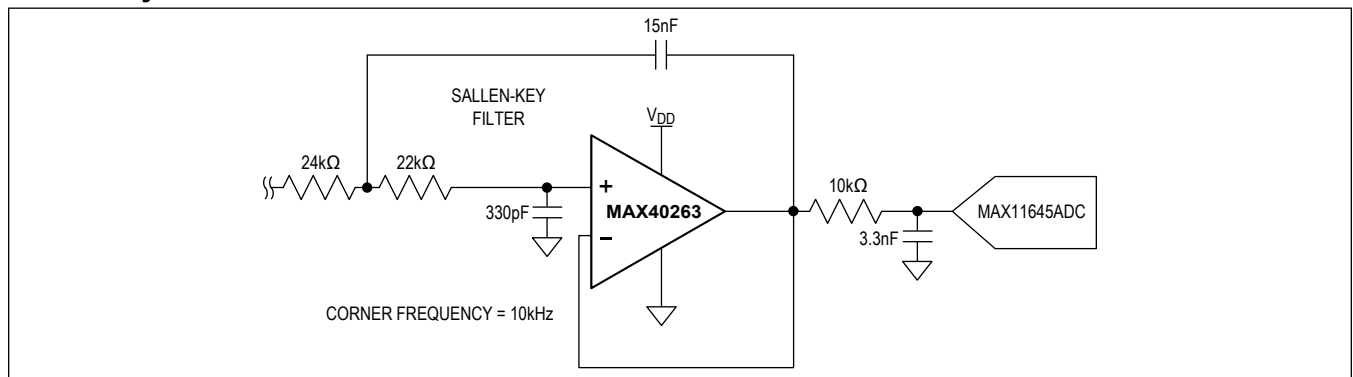

Ordering Information

| PART NUMBER | TEMP RANGE | PIN-PACKAGE | TOP MARK |
|---------------|-----------------|-------------|----------|
| MAX40263AVB+T | -40°C to +125°C | 10-UTQFN | +ABI |

+Denotes a lead(Pb)-free/RoHS-compliant package.

MAX40263

1.8V, 15MHz, Low-Offset, Low-Power, Rail-to-Rail
Dual Op-Amp with Individual Shutdown

Revision History

| REVISION NUMBER | REVISION DATE | DESCRIPTION | PAGES CHANGED |
|-----------------|---------------|--|---------------|
| 0 | 3/22 | Release for Market Intro | — |
| 1 | 4/22 | Updated <i>Benefits and Features</i> section | 1 |