

SAW Filter for Mobile Communication 2140MHz

Model: TA0174A

Part No: MA04452

Rev No: 2

A. MAXIMUM RATING:

Electrostatic Sensitive Device (ESD)

1. Input Power Level: 13dBm
2. DC voltage: 0V
3. Operating Temperature: -30°C to +80°C
4. Storage Temperature: -40°C to +85°C

B. ELECTRICAL CHARACTERISTICS:

Item	Min.	Typ.	Max.
Center frequency Fc (dB)	-	2140	-
Insertion loss within 2110 ~ 2170MHz IL (dB)	-	2.1	3.5
Amplitude ripple (p-p) within 2110 ~ 2170MHz (dB)	-	0.6	2.0
Attenuation (Reference level from 0dB)			
D.C. ~ 500MHz (dB)	21.0	33.0	-
500 ~ 1900MHz (dB)	20.0	28.0	-
1900 ~ 2050MHz (dB)	25.0	30.0	-
2215 ~ 2300MHz (dB)	20.0	32.0	-
2300 ~ 4500MHz (dB)	25.0	32.0	-
VSWR within 2110 ~ 2170MHz	-	1.9	2.2
Source impedance Z _S (Ω)	-	50	-
Load impedance Z _L (Ω)	-	50	-

Note: No matching network required for operation at 50Ω

C. MEASUREMENT CIRCUIT:

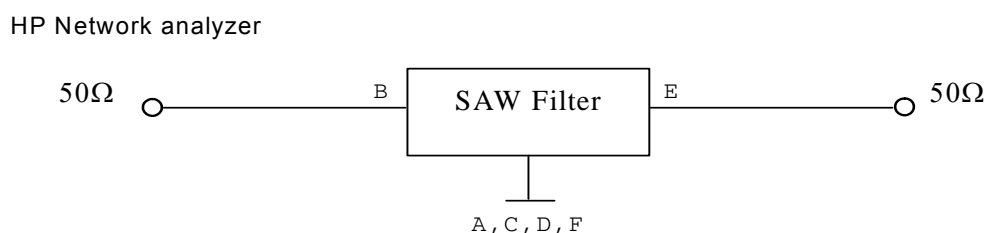

SAW Filter for Mobile Communication 2140MHz
Part No: MA04452

Model: TA0174A
Rev No: 2

D. FREQUENCY CHARACTERISTICS:

1. Transfer functions

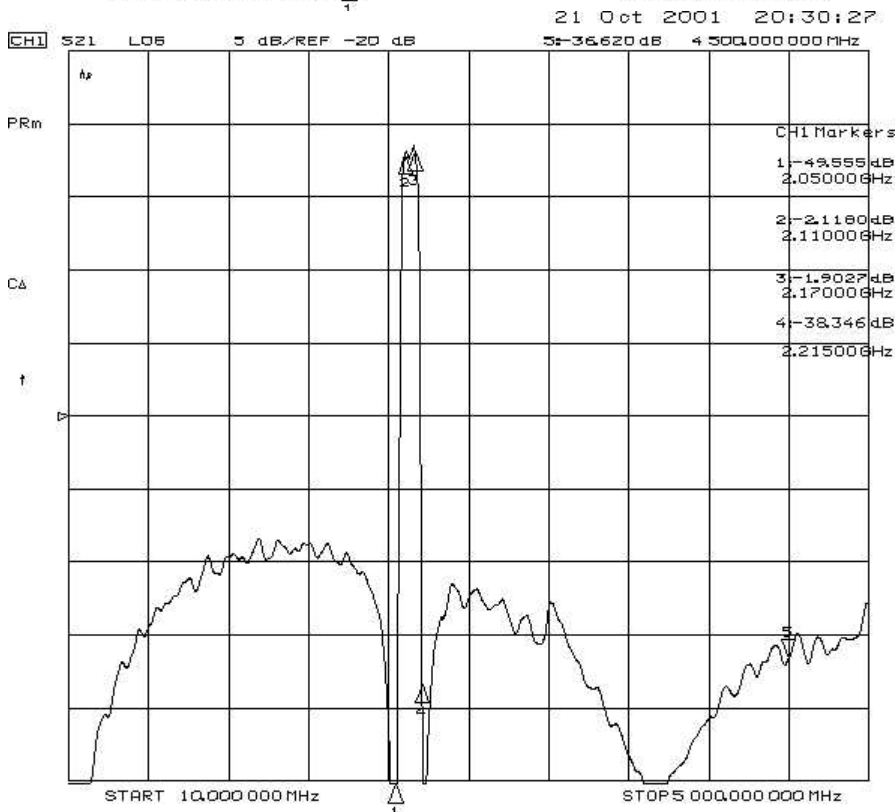
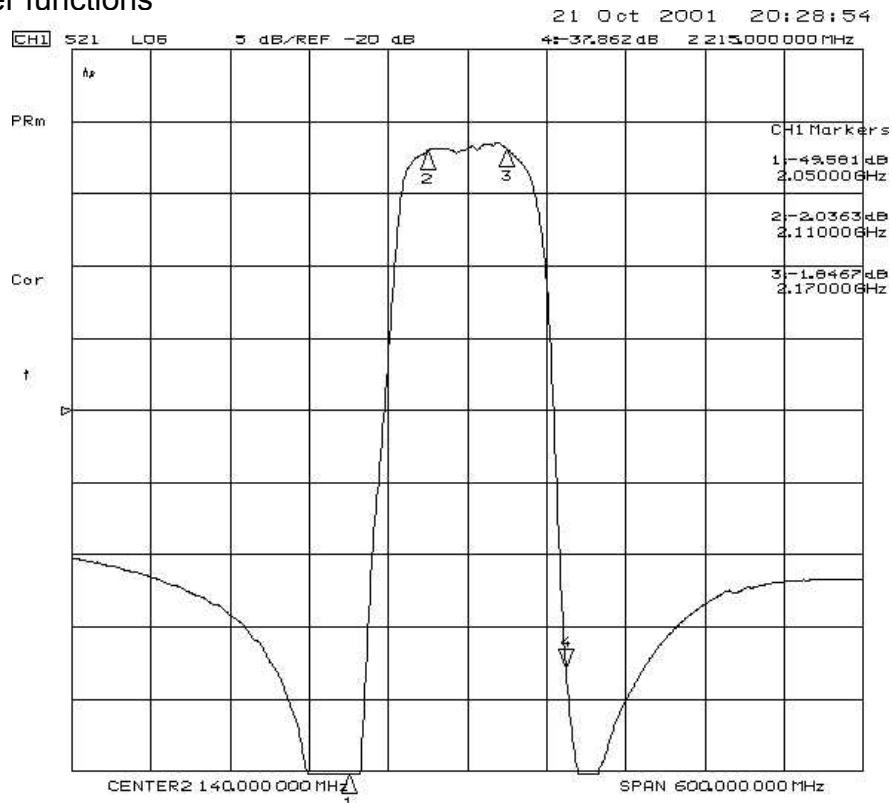

SAW Filter for Mobile Communication 2140MHz
Part No: MA04452

Model: TA0174A
Rev No: 2

2. Reflection Functions:

S11 VSWR

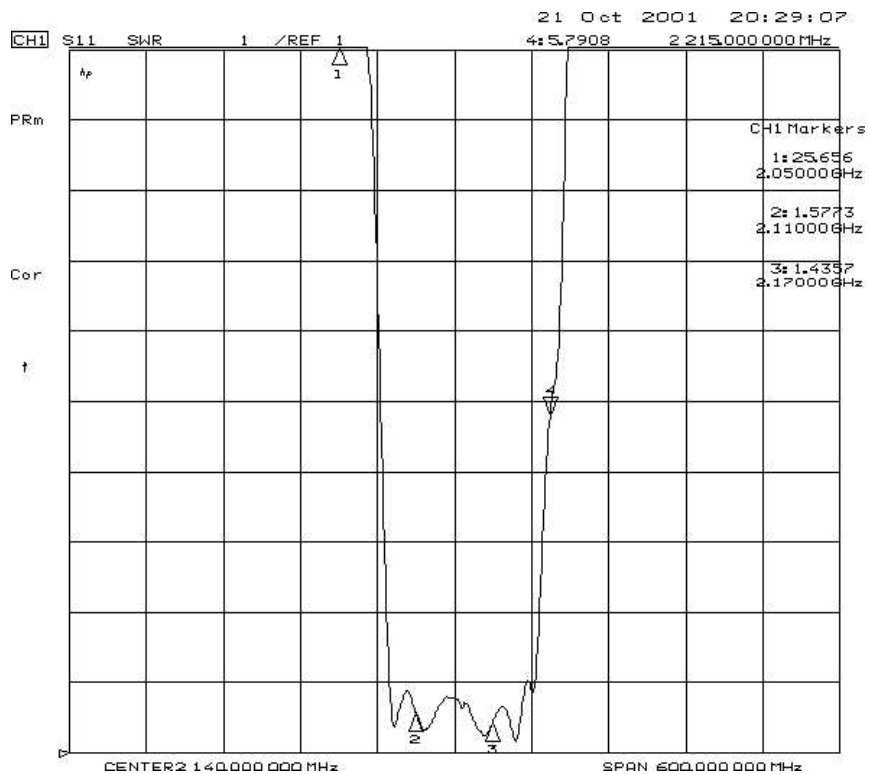
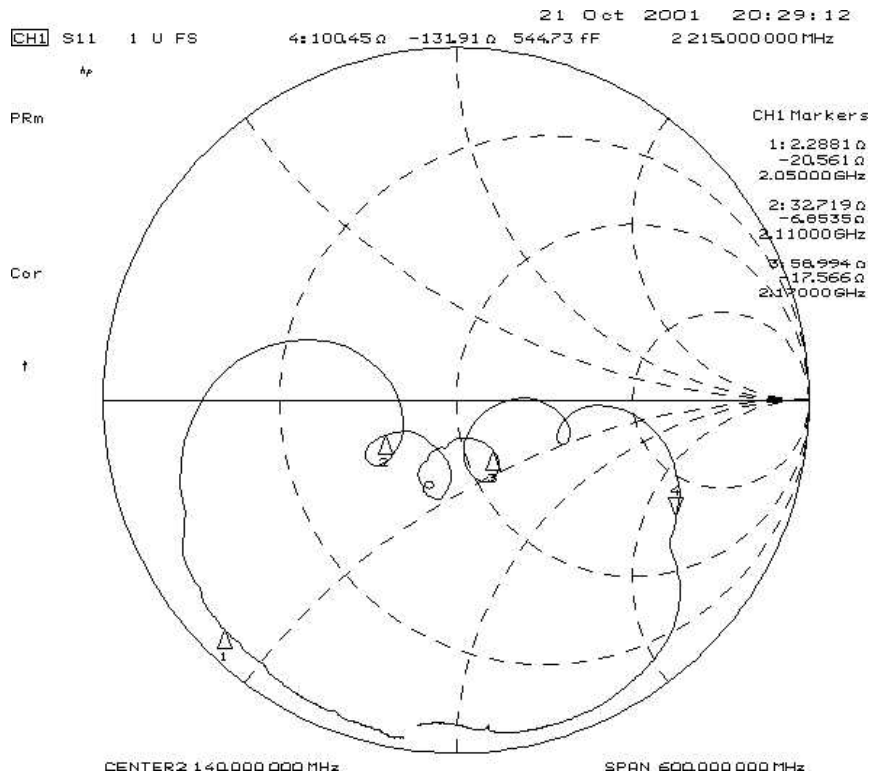

SAW Filter for Mobile Communication 2140MHz
Part No: MA04452

Model: TA0174A
Rev No: 2

S22 VSWR

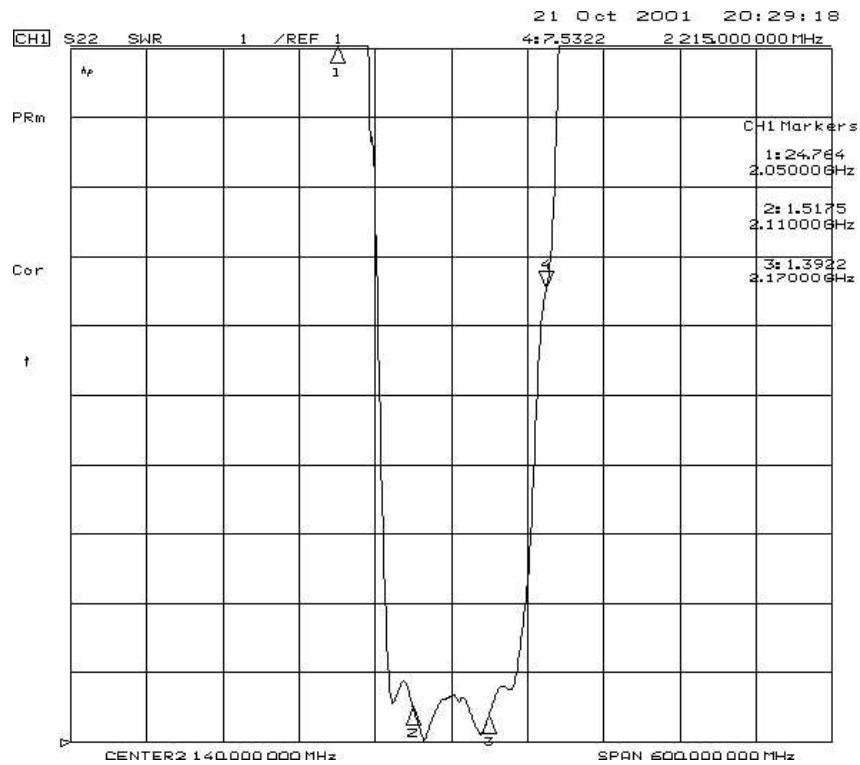
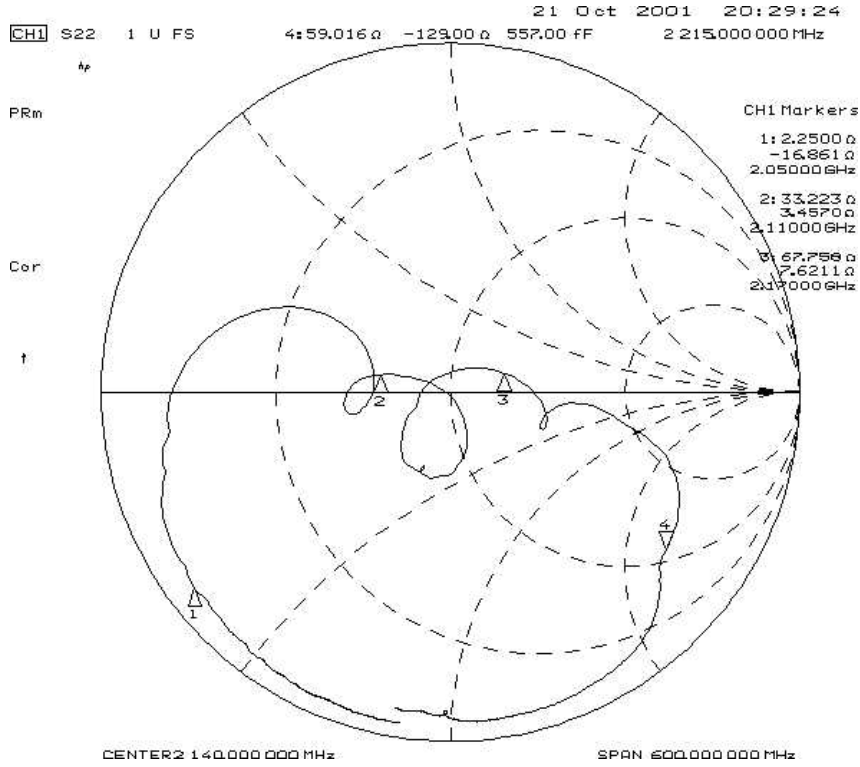

SAW Filter for Mobile Communication 2140MHz
Part No: MA04452

Model: TA0174A
Rev No: 2

E. OUTLINE DRAWING:

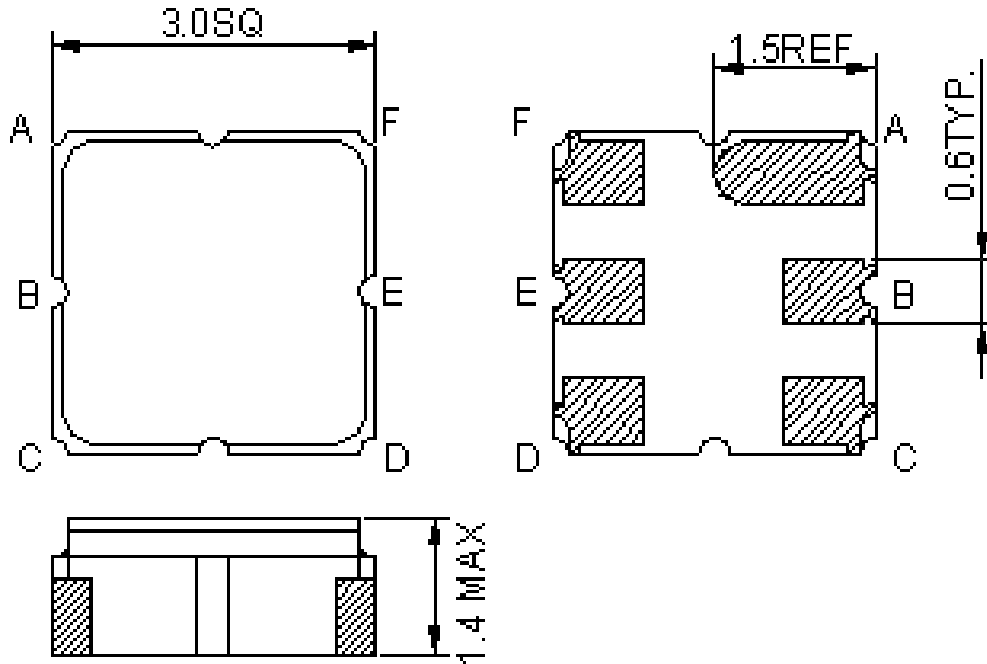

F. PCB FOOTPRINT:

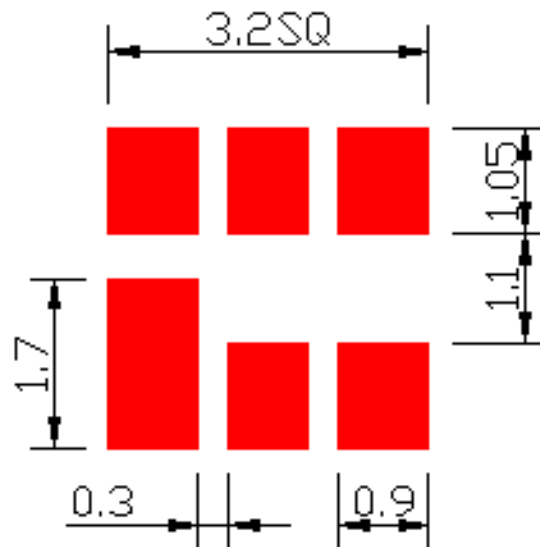

SAW Filter for Mobile Communication 2140MHz
Part No: MA04452

Model: TA0174A
Rev No: 2

G. PACKING:

1. Reel Dimension

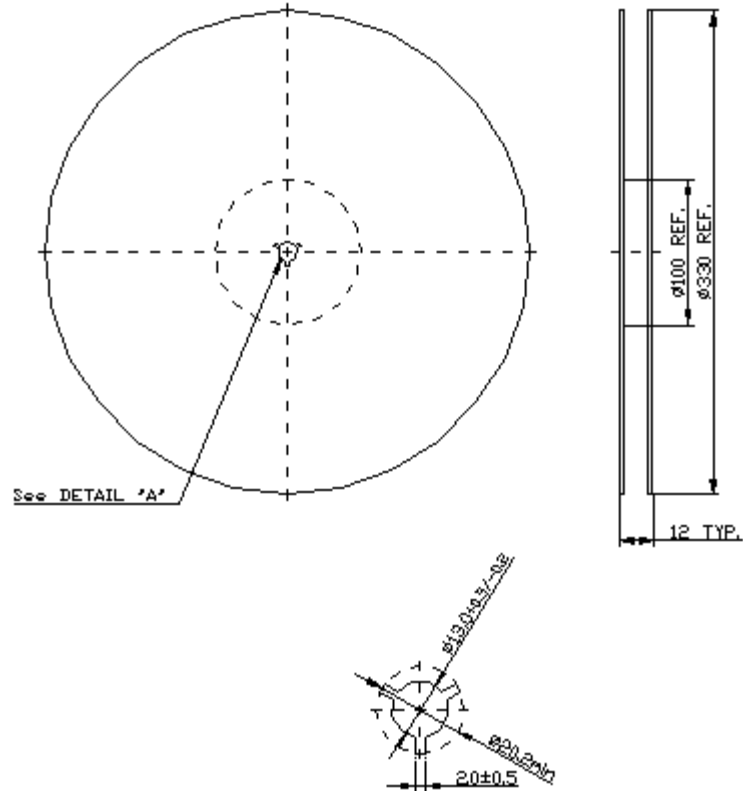

2. Tape Dimension

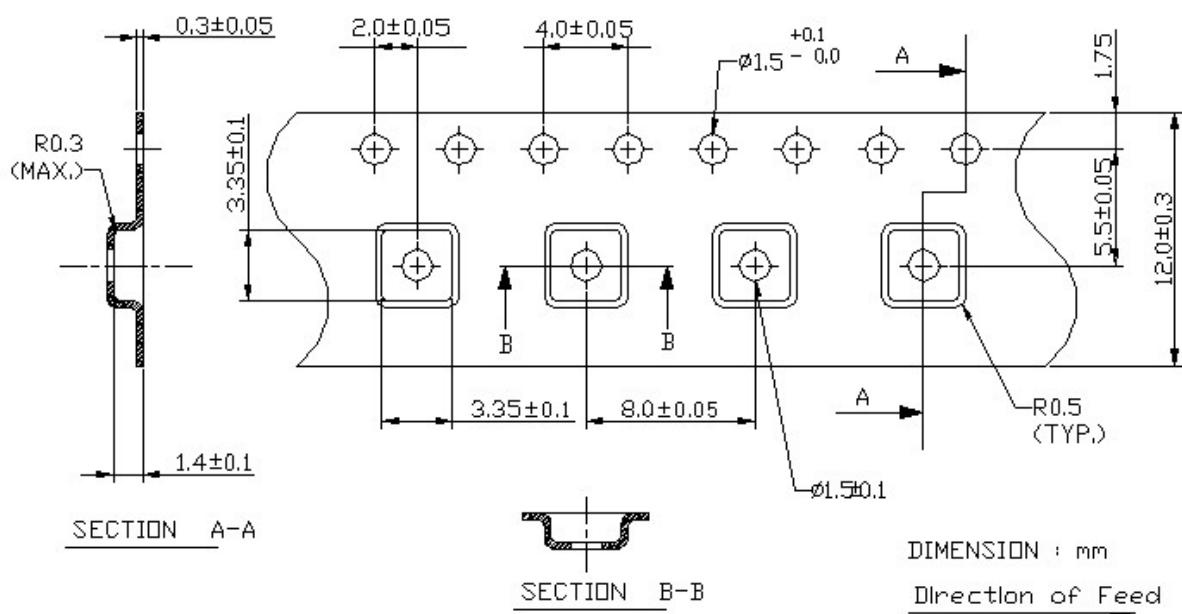

SAW Filter for Mobile Communication 2140MHz
Part No: MA04452

Model: TA0174A
Rev No: 2

H. RECOMMENDED REFLOW PROFILE:

1. Preheating shall be fixed at 150 ~ 180°C for 60 ~ 90 seconds.
2. Ascending time to preheating temperature 150°C shall be 30 seconds min.
3. Heating shall be fixed at 220°C for 50 ~ 80 seconds and at 245 ~ 260°C peak (min. 10 sec).
4. Time: 2 times.

