

REVISION Y

DO NOT SCALE FROM THIS PRINT

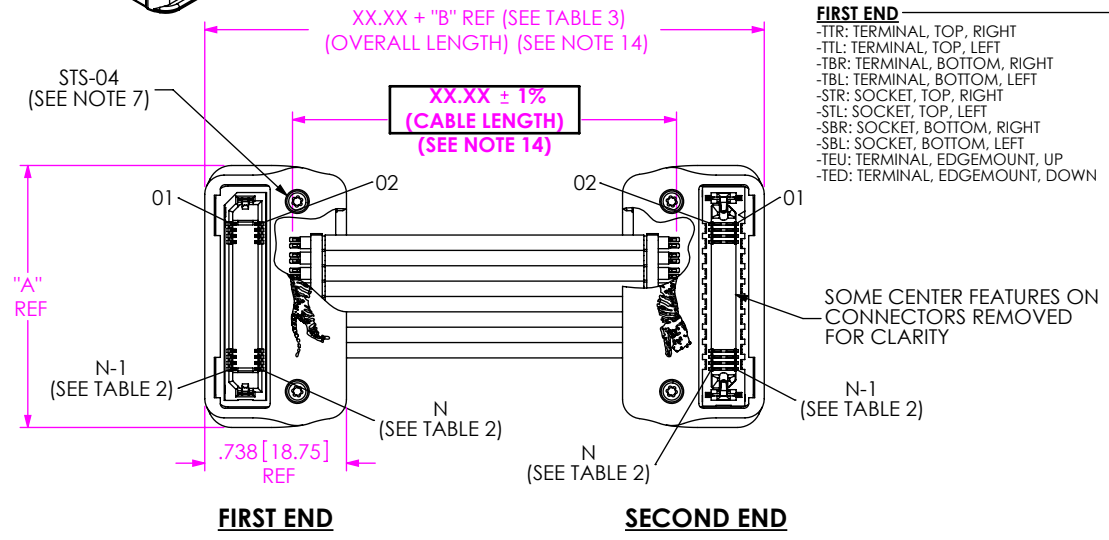
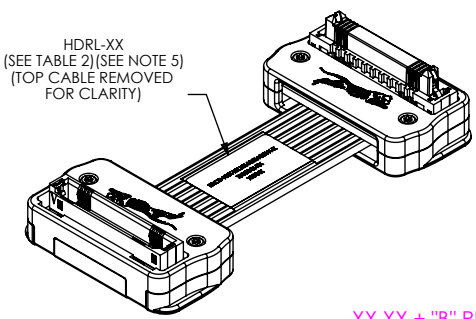

ERDP-XXX-XX.XX-XXX-XXX-X-X

- No OF POSITIONS**
- 013 (8 PAIR)
 - 025 (16 PAIR)
 - 049 (32 PAIR) (PER ROW)
- LENGTH**
- XX.XX (INCHES) (01.72[43.7] MIN) (SEE NOTE 8) (SEE NOTE 9)
- FIRST END**
- TR: TERMINAL, TOP, RIGHT
 - TL: TERMINAL, TOP, LEFT
 - BR: TERMINAL, BOTTOM, RIGHT
 - BL: TERMINAL, BOTTOM, LEFT
 - SR: SOCKET, TOP, RIGHT
 - SL: SOCKET, TOP, LEFT
 - SBR: SOCKET, BOTTOM, RIGHT
 - SBL: SOCKET, BOTTOM, LEFT
 - TEU: TERMINAL, EDGEMOUNT, UP
 - TED: TERMINAL, EDGEMOUNT, DOWN
- LATCH OPTION**** (SEE NOTE 11)
- *L: 1ST END STD LATCH, 2ND END SQUEEZE LATCH
 - *R: 1ST END SQUEEZE LATCH, 2ND END STD LATCH
 - D: BOTH ENDS STD LATCH
 - N: NO CAPS (BOTH ENDS HAVE STD LATCH)
 - *B: BOTH ENDS SQUEEZE LATCH
 - F: 1ST END SCREW OPTION, 2ND END FRICTION LATCH
 - S: 1ST END FRICTION LATCH, 2ND END SCREW OPTION
 - C: BOTH ENDS SCREW OPTION
 - ***G: 1ST END SCREW OPTION, 2ND END SQUEEZE LATCH
 - ***T: 1ST END SQUEEZE LATCH, 2ND END SCREW OPTION
 - *1: BOTH ENDS EXTENDED HOUSING SQUEEZE LATCH
 - *2: FIRST END FRICTION LATCH, 2ND END EXTENDED HOUSING SQUEEZE LATCH
 - *3: FIRST END EXTENDED HOUSING SQUEEZE LATCH, 2ND END, FRICTION LATCH
 - ***4: FIRST END SCREW OPTION, 2ND END EXTENDED HOUSING SQUEEZE LATCH
 - ***5: FIRST END EXTENDED HOUSING SQUEEZE LATCH, 2ND END SCREW OPTION
- WIRING OPTION**
- ****-1: PIN 1 TO PIN 1 -5: PIN 1 TO PIN 1
 - ****-2: PIN 1 TO PIN 2 -6: PIN 1 TO PIN 2
 - ****-3: PIN 1 TO PIN N-1 -7: PIN 1 TO PIN N-1
 - ****-4: PIN 1 TO PIN N -8: PIN 1 TO PIN N
- (SEE NOTE 12)
- SECOND END**
- TR: TERMINAL, TOP, RIGHT
 - TL: TERMINAL, TOP, LEFT
 - BR: TERMINAL, BOTTOM, RIGHT
 - BL: TERMINAL, BOTTOM, LEFT
 - SR: SOCKET, TOP, RIGHT
 - SL: SOCKET, TOP, LEFT
 - SBR: SOCKET, BOTTOM, RIGHT
 - SBL: SOCKET, BOTTOM, LEFT
 - TEU: TERMINAL, EDGEMOUNT, UP
 - TED: TERMINAL, EDGEMOUNT, DOWN

*OPTION ONLY AVAILABLE WITH -TEX OPTIONS (SEE NOTE 10)

**LATCH OPTION REQUIRED, PART NUMBER MUST BE COMPLETE TO BE VALID

***SQUEEZE LATCH TEX OPTIONS ONLY

****: AVAILABLE TO EXISTING CUSTOMERS ONLY

THIS PRODUCT MANUFACTURED WITH LEAD-FREE PROCESSING

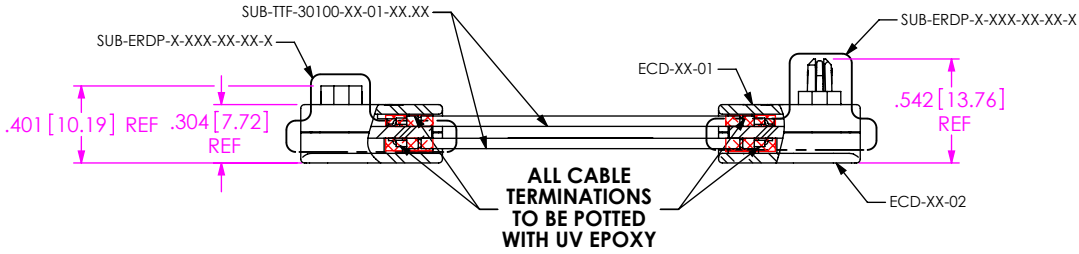

FIG 1
(ERDP-025-XX.XX-STL-TTR-1-D SHOWN)

- NOTES:
1. REPRESENTS A CRITICAL DIMENSION.
 2. PARTS TO BE PROCESSED PER SAMTEC ACCEPTABILITY REQUIREMENTS: HDR-PI-01 "CABLE ASSEMBLY WORKMANSHIP STANDARDS".
 3. ALL ASSEMBLIES TO BE 100% ELECTRICALLY TESTED.
 4. ALL ASSEMBLIES TO BE 100% HI-POT TESTED AT 300V.
 5. LABEL TO BE CENTERED ON LOWER CABLE AS SHOWN. LABEL TO CONTAIN:
LINE 1 - PART NUMBER "ERDP-XXX-XX.XX-XXX-XXX-X-X"
LINE 2 - SHOP ORDER NUMBER "XXXXXX"
LINE 3 - DATE CODE "XXXXX"
 6. FOR PACKAGING REQUIREMENTS REFERENCE PACKAGING STANDARDS.
 7. TIGHTEN STS-04 FASTENERS TO 1.4-1.7 IN-LBS (4 PLCS).
 8. SUB-TCF LENGTH IS EQUAL TO ERCD LENGTH.
 9. CABLE LENGTHS LONGER THAN 40.00 INCHES ARE NOT SUPPORTED BY S.I. TEST DATA.
 10. -B & -1 OPTION ONLY AVAILABLE WITH -TEX ON BOTH ENDS. -L, -2, -G & -4 OPTIONS ONLY AVAILABLE WITH -TEX ON 2ND END. -R, -3, -T & -5 OPTION ONLY AVAILABLE WITH -TEX ON FIRST END.
 11. THE RECOMMENDED MATING CONNECTOR IS THE ERF8 OR ERM8 WITH -L LATCHING OPTION.
 12. WIRING OPTION -5 THROUGH -8 USE 30100CU.
 13. REFER TO PREP-SPEC DRAWING FOR CABLE PREP DIMENSIONS. ASSEMBLY USES STANDARD PCB PREP.
 14. FOR CABLE LENGTHS LESS THAN 5 INCHES, CABLE LENGTH AND OVERALL LENGTH TOLERANCE IS ±0.05 INCHES. FOR CABLE LENGTHS GREATER THAN 5 INCHES, USE ±1% FOR BOTH.

# OF POSITIONS	N	N-1	HDRL-XX
-013	26	25	HDRL-11
-025	50	49	HDRL-11
-049	98	97	HDRL-13

END TO END	"B"
DV TO DV	.924[23.47]
DV TO EM (-TXX)	1.051[26.69]
EM (-TXX) TO EM (-TXX)	1.178[29.92]

# OF POSITIONS	"A"	XCD-XX-01	XCD-XX-02	CABLE CALLOUT		QTY	SUB-ERDP-X-XXX-XX-XX-X (SEE TABLE 7)
				WIRING OPTION			
-013	1.018[25.86]	ECD-13-01	ECD-13-02	SUB-TTF-30100-04-01-XX.XX	SUB-TTF-30100CU-04-01-XX.XX	2	SUB-ERDP-X-013-XX-XX-X
-025	1.3645[34.66]	ECD-25-01	ECD-25-02	SUB-TTF-30100-08-01-XX.XX	SUB-TTF-30100CU-08-01-XX.XX	2	SUB-ERDP-X-025-XX-XX-X
-049	2.120[53.85]	ECD-49-01	ECD-49-02	SUB-TTF-30100-16-01-XX.XX	SUB-TTF-30100CU-16-01-XX.XX	2	SUB-ERDP-X-049-XX-XX-X

SEE TABLE 8 (SHEET 6)
F:\DWG\MISC\MKTG\ERDP-XXX-XX.XX-XXX-XXX-X-X-MKT.SLDDRW

TOLERANCES DO NOT APPLY TO REFERENCE DIMENSIONS. UNLESS OTHERWISE SPECIFIED, DIMENSIONS ARE IN INCHES. TOLERANCES ARE:
DECIMALS .XX: ±0.1[3]
.XXX: ±0.005[.13]
.XXXX: ±0.002[.051]

PROPRIETARY NOTE
THIS DOCUMENT CONTAINS CONFIDENTIAL AND PROPRIETARY INFORMATION AND ALL DESIGN, MANUFACTURING, REPRODUCTION, USE, PATENT RIGHTS AND SALES RIGHTS ARE EXPRESSLY RESERVED BY SAMTEC, INC. THIS DOCUMENT SHALL NOT BE DISCLOSED, IN WHOLE OR PART, TO ANY UNAUTHORIZED PERSON OR ENTITY NOR REPRODUCED, TRANSFERRED OR INCORPORATED IN ANY OTHER PROJECT IN ANY MANNER WITHOUT THE EXPRESS WRITTEN CONSENT OF SAMTEC, INC.



520 PARK EAST BLVD, NEW ALBANY, IN 47150
PHONE: 812-944-6733 FAX: 812-948-5047
e-Mail info@SAMTEC.com code 55322

MATERIAL: PLATING: -S GOLD: 30µ" CONTACT	DO NOT SCALE DRAWING	SHEET SCALE: 1:1	DESCRIPTION: 0.8MM EDGE RATE TWIN-AX CABLE ASSEMBLY
DWG. NO.			ERDP-XXX-XX.XX-XXX-XXX-X-X
BY: J. BORGELT 1/21/2008		SHEET 1 OF 6	

REVISION Y

FIRST END

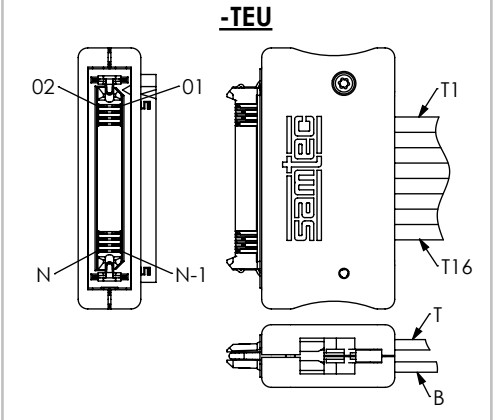
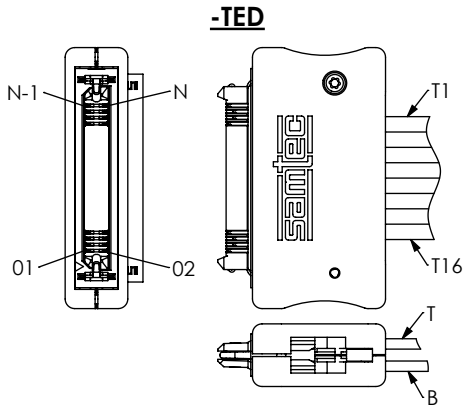
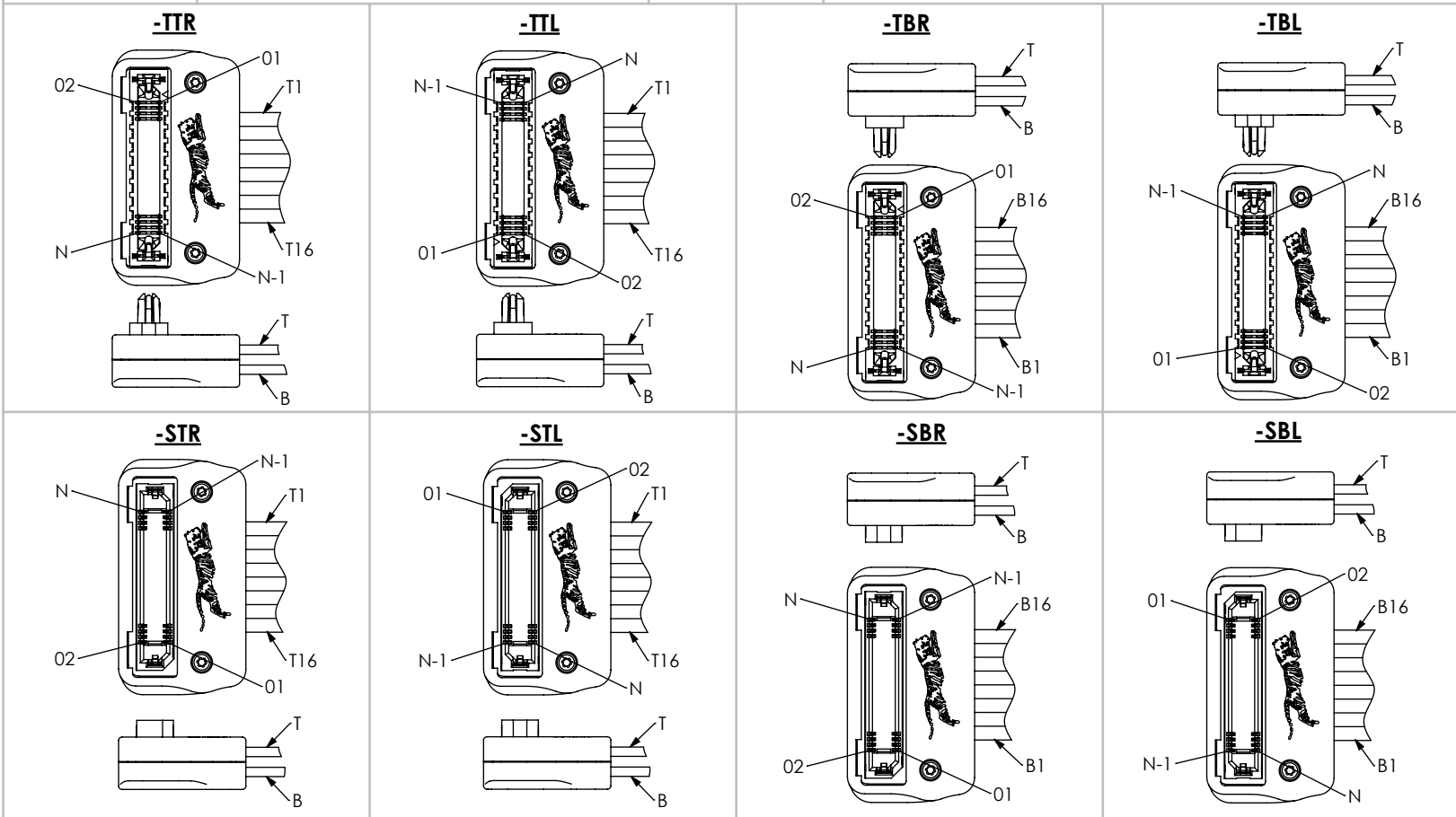

PROPRIETARY NOTE
 THIS DOCUMENT CONTAINS CONFIDENTIAL AND PROPRIETARY INFORMATION AND ALL DESIGN, MANUFACTURING, REPRODUCTION, USE, PATENT RIGHTS AND SALES RIGHTS ARE EXPRESSLY RESERVED BY SAMTEC, INC. THIS DOCUMENT SHALL NOT BE DISCLOSED, IN WHOLE OR PART, TO ANY UNAUTHORIZED PERSON OR ENTITY NOR REPRODUCED, TRANSFERRED OR INCORPORATED IN ANY OTHER PROJECT IN ANY MANNER WITHOUT THE EXPRESS WRITTEN CONSENT OF SAMTEC, INC.

DO NOT SCALE DRAWING



520 PARK EAST BLVD, NEW ALBANY, IN 47150
 PHONE: 812-944-6733 FAX: 812-948-5047
 e-Mail info@SAMTEC.com code 55322

DESCRIPTION:
 CUSTOM HDR CABLE ASSEMBLY

DWG. NO.
ERDP-XXX-XX.XX-XXX-XXX-X-X

BY: J. BORGELT 1/21/2008 SHEET 2 OF 6

SECOND END

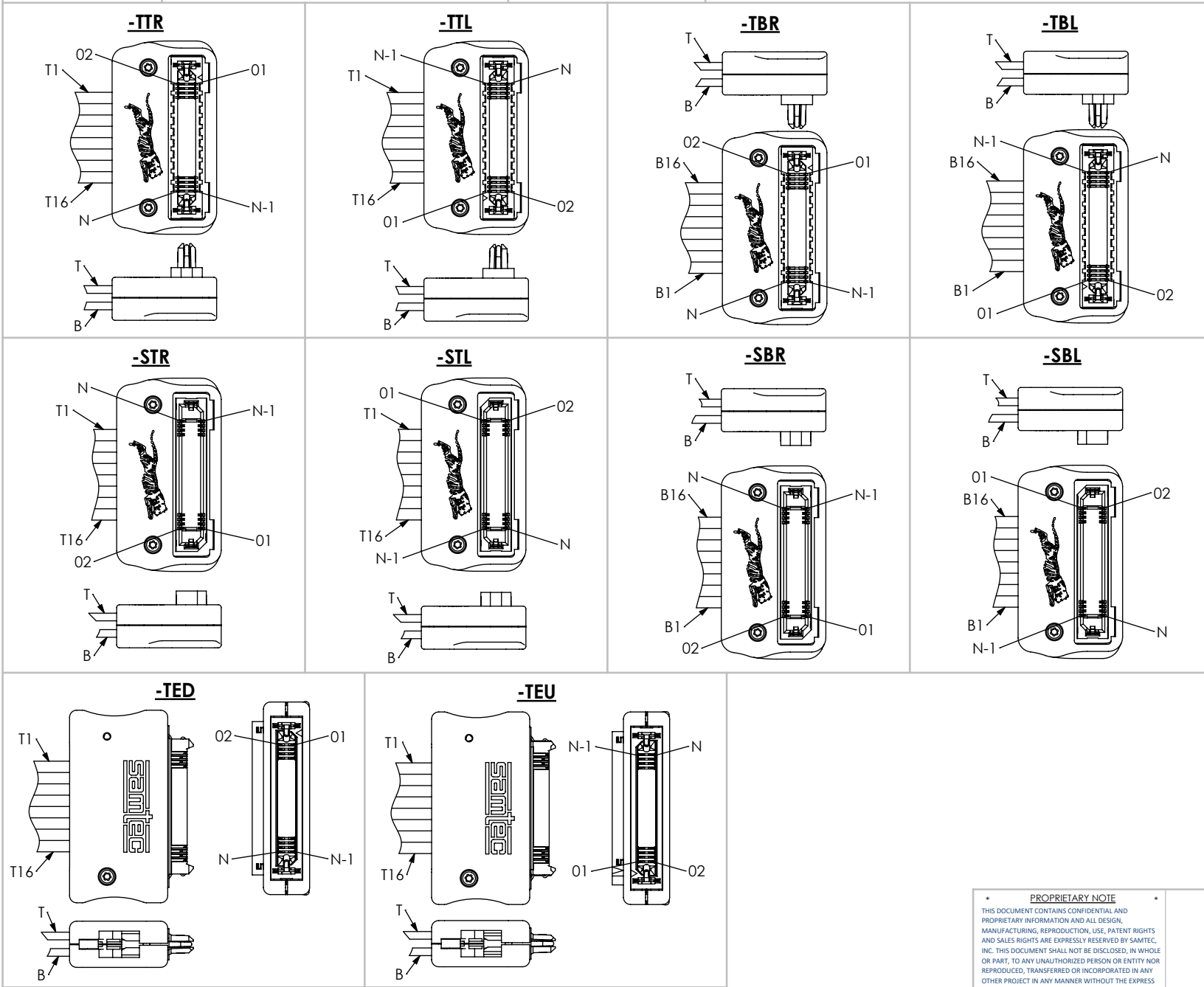

PROPRIETARY NOTE
 THIS DOCUMENT CONTAINS CONFIDENTIAL AND PROPRIETARY INFORMATION AND ALL DESIGN, MANUFACTURING, REPRODUCTION, USE, PATENT RIGHTS AND SALES RIGHTS ARE EXPRESSLY RESERVED BY SAMTEC, INC. THIS DOCUMENT SHALL NOT BE DISCLOSED, IN WHOLE OR PART, TO ANY UNAUTHORIZED PERSON OR ENTITY NOR REPRODUCED, TRANSFERRED OR INCORPORATED IN ANY OTHER PROJECT IN ANY MANNER WITHOUT THE EXPRESS WRITTEN CONSENT OF SAMTEC, INC.



520 PARK EAST BLVD, NEW ALBANY, IN 47150
 PHONE: 812-944-6733 FAX: 812-948-5047
 e-Mail info@SAMTEC.com code 55322

DO NOT SCALE DRAWING

DESCRIPTION: CUSTOM HDR CABLE ASSEMBLY

SHEET SCALE: 1:1

DWG. NO. ERDP-XXX-XX.XX-XXX-XXX-X-X

BY: J. BORGELT 1/21/2008 SHEET 3 OF 6

REVISION Y

FIG 2
(ERDP-025-XX.XX-TED-TEU-2-R SHOWN)

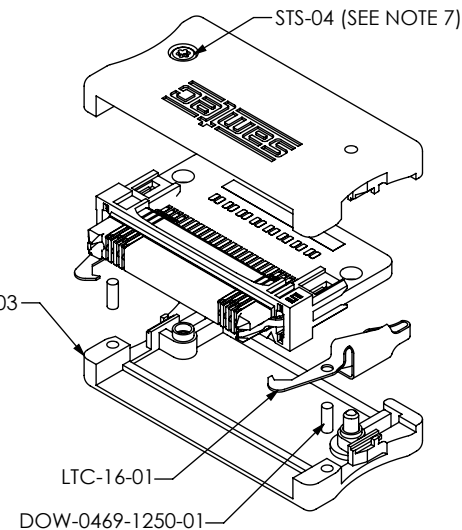
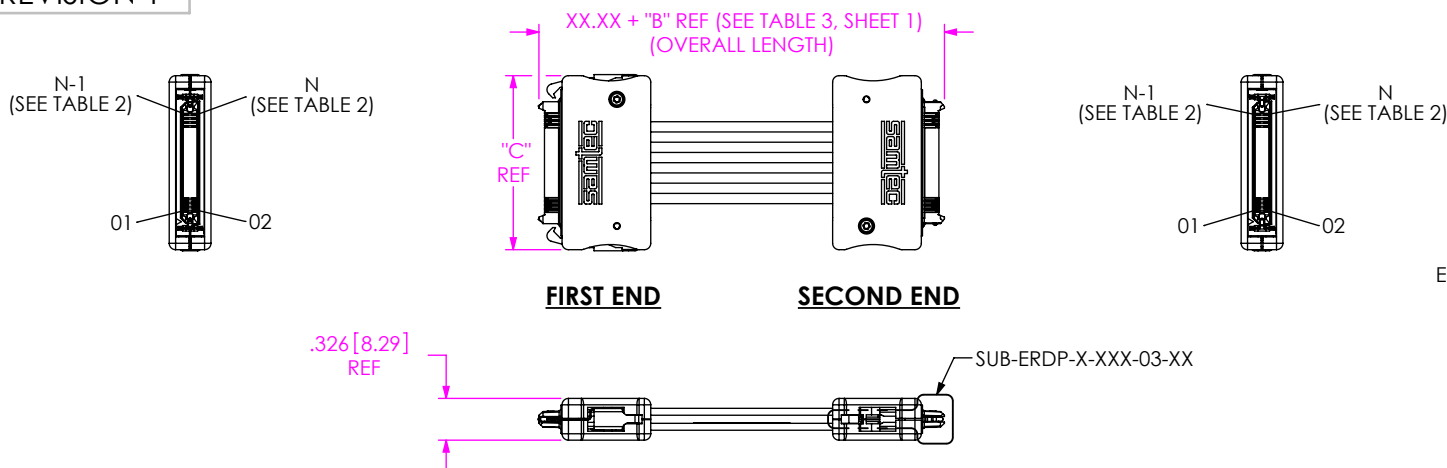

TABLE 9					
SUB-ERDP-T-XXX-03-XX-XXX			DOW-0469-1250-01	LCT-16-01	CPS-4-40-11-X
END OPTION	END 1	END 2	QTY	QTY	QTY
-L	-03-XX-DSL	-03-XX-DSB	2	2	0
-R	-03-XX-DSB	-03-XX-DSL	2	2	0
-D	-03-XX-DSL	-03-XX-DSL	0	0	0
-B	-03-XX-DSB	-03-XX-DSB	4	4	0
-N	-03-XX-DSL	-03-XX-DSL	0	0	0
-F	-03-XX-DSB	-03-XX-DSL	0	0	2
-S	-03-XX-DSL	-03-XX-DSB	0	0	2
-C	-03-XX-DSB	-03-XX-DSB	0	0	4
-G	-03-XX-DSB	-03-XX-DSB	2	2	2
-T	-03-XX-DSB	-03-XX-DSB	2	2	2

TABLE 4					
# OF POSITIONS	"C"	XCD-XX-03	SUB-ERDP-X-XXX-03-XX-X (SEE TABLE 7 FOR FINOUT AVAIL.) (SEE TABLE 9 FOR LATCH CONFIG.)		
			WIRING OPTION		
-013	.977[24.82]	ECD-13-03	SUB-ERDP-X-013-03-XX-X	-1, -2, -3, -4	-5, -6, -7, -8
-025	1.324[33.63]	ECD-25-03	SUB-ERDP-X-025-03-XX-X	30100XX-XX-01	30100CU-XX-
-049	2.080[52.83]	ECD-49-03	SUB-ERDP-X-049-03-XX-X	XX.XX	01-XX.XX

FIG 3
(ERDP-025-XX.XX-STL-TTR-1-N SHOWN)

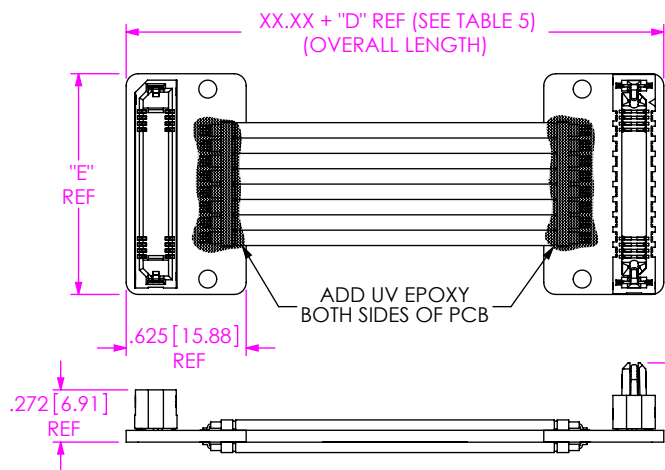

TABLE 5	
END TO END	"D"
DV TO DV	.810[20.57]
DV TO EM (-TXX)	.994[25.24]
EM (-TXX) TO EM (-TXX)	1.178[29.92]

TABLE 6		
# OF POSITIONS	"E"	"F"
-013	.803[20.40]	.764[19.39]
-025	1.150[29.20]	1.142[28.99]
-049	1.906[48.40]	1.898[48.20]

FIG 4
(ERDP-025-XX.XX-XXX-TEU-1-N SHOWN)

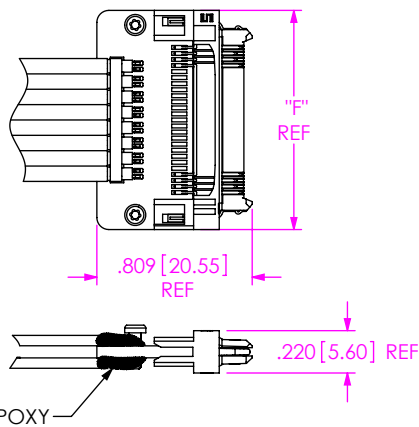

FIG 5
(ERDP-025-XX.XX-XXX-TEU-1-S SHOWN)

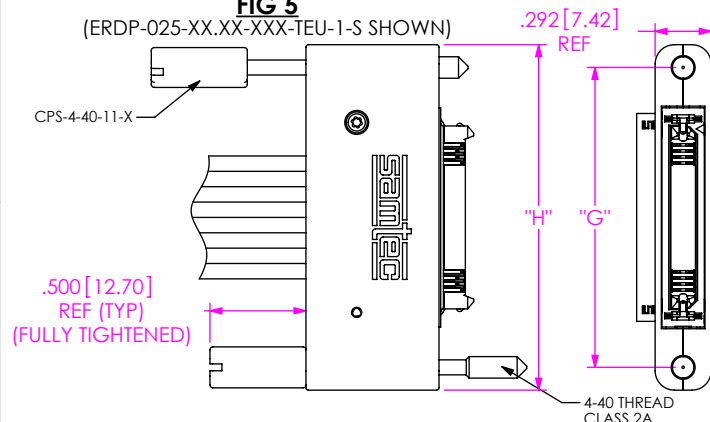

TABLE 10					
# OF POSITIONS	"G"	"H"	XCD-XX-03-CPS	WIRING OPTION	
				-1, -2, -3, -4	-5, -6, -7, -8
-013	1.184 [30.0736]	1.420 [36.0680]	ECD-13-03-CPS	SUB-TTF-	SUB-TTF-
-025	1.562 [39.6748]	1.798 [45.6692]	ECD-25-03-CPS	30100XX-XX-	30100CU-XX-
-049	2.318 [58.8772]	2.554 [64.8716]	ECD-49-03-CPS	01-XX.XX	01-XX.XX

PROPRIETARY NOTE
THIS DOCUMENT CONTAINS CONFIDENTIAL AND PROPRIETARY INFORMATION AND ALL DESIGN, MANUFACTURING, REPRODUCTION, USE, PATENT RIGHTS AND SALES RIGHTS ARE EXPRESSLY RESERVED BY SAMTEC, INC. THIS DOCUMENT SHALL NOT BE DISCLOSED, IN WHOLE OR PART, TO ANY UNAUTHORIZED PERSON OR ENTITY NOR REPRODUCED, TRANSFERRED OR INCORPORATED IN ANY OTHER PROJECT IN ANY MANNER WITHOUT THE EXPRESS WRITTEN CONSENT OF SAMTEC, INC.



520 PARK EAST BLVD, NEW ALBANY, IN 47150
PHONE: 812-944-6733 FAX: 812-948-5047
e-Mail info@SAMTEC.com code 55322

DO NOT SCALE DRAWING

DESCRIPTION: CUSTOM HDR CABLE ASSEMBLY

SHEET SCALE: 1:1

DWG. NO. ERDP-XXX-XX.XX-XXX-XXX-X-X

BY: J. BORGELT 1/21/2008 SHEET 4 OF 6

FIG 6
ERDP-025-XX.XX-TED-TEU-2-1 SHOWN

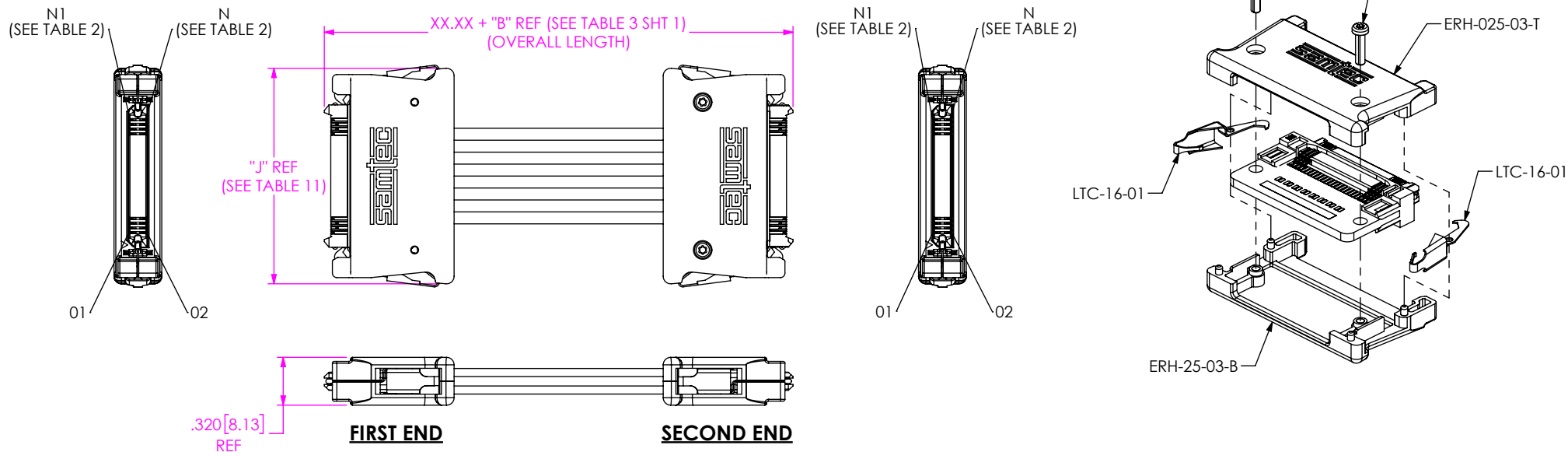
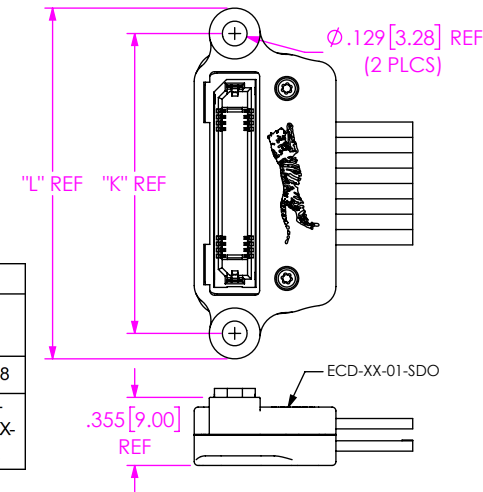

FIG 7
(ERDP-025-XX.XX-STL-XXX-1-F SHOWN)
(DIFFERENT AS SHOWN, OTHERWISE SAME AS FIG 1)



# OF POSITIONS	"J"	TOP HOUSING (PIN 1 SIDE)	BOTTOM HOUSING	SUB-ERDP-X-XXX-03-XX-X (SEE TABLE 7 FOR PINOUT AVAILABILITY) (SEE TABLE 12 FOR LATCH CONFIG)	WIRING OPTION	
					-1, -2, -3, -4	-5, -6, -7, -8
-013	1.064[27.03]	ERH-13-03-T	ERH-13-03-B	SUB-ERDP-X-013-03-XX-X	SUB-TTF-30100XX-XX-01-XX-XX	SUB-TTF-30100CU-XX-01-XX-XX
-025	1.442[36.64]	ERH-25-03-T	ERH-25-03-B	SUB-ERDP-X-025-03-XX-X		
-049	2.197[55.83]	ERH-49-03-T	ERH-49-03-B	SUB-ERDP-X-049-03-XX-X		

No OF POSITIONS	"K"	"L"	TOP HOUSING	WIRING OPTION	
				-1, -2, -3, -4	-5, -6, -7, -8
-013	1.1840 [30.074]	1.449 [36.80]	ECD-13-01-SDO	SUB-TTF-30100XX-XX-01-XX-XX	SUB-TTF-30100CU-XX-01-XX-XX
-025	1.5620 [39.675]	1.827 [46.41]	ECD-25-01-SDO		
-049	2.3180 [58.877]	2.583 [65.61]	ECD-49-01-SDO		

LATCH OPTION	SUB-XRDP-X-XXX-03-XX-X		LTC-16-01	CPS-4-40-11-X
	END 1	END 2	QUANTITY	QUANTITY
-1	-03-XX-DSB	-03-XX-DSB	4	0
-2	-03-XX-DSL	-03-XX-DSB	2	0
-3	-03-XX-DSB	-03-XX-DSL	2	0
-4	-03-XX-DSB	-03-XX-DSB	2	2
-5	-03-XX-DSB	-03-XX-DSB	2	2

PROPRIETARY NOTE
THIS DOCUMENT CONTAINS CONFIDENTIAL AND PROPRIETARY INFORMATION AND ALL DESIGN, MANUFACTURING, REPRODUCTION, USE, PATENT RIGHTS AND SALES RIGHTS ARE EXPRESSLY RESERVED BY SAMTEC, INC. THIS DOCUMENT SHALL NOT BE DISCLOSED, IN WHOLE OR PART, TO ANY UNAUTHORIZED PERSON OR ENTITY NOR REPRODUCED, TRANSFERRED OR INCORPORATED IN ANY OTHER PROJECT IN ANY MANNER WITHOUT THE EXPRESS WRITTEN CONSENT OF SAMTEC, INC.

DO NOT SCALE DRAWING

SHEET SCALE: 1:1

samtec
520 PARK EAST BLVD, NEW ALBANY, IN 47150
PHONE: 812-944-6733 FAX: 812-948-5047
e-Mail info@SAMTEC.com code 53322

DESCRIPTION:
0.8MM EDGE RATE TWIN-AX CABLE ASSEMBLY
DWG. NO.
ERDP-XXX-XX.XX-XXX-XXX-X-X
BY: J. BORGELT 1/21/2008 SHEET 5 OF 6

		TABLE 7															
FIRST END OPTION	FIRST END SUB-ERDP-X-XXX-XX-01-XXX	WIRING OPTION	FIRST END PIN #	SECOND END PIN #	WIRE #	SECOND END OPTION (SUB-ERDP-X-XXX-XX-XXX)										-TEU	-TED
						-TTR	-TTL	-TBR	-TBL	-STR	-STL	-SBR	-SBL				
-TTR	-T-XXX-01-01-XXX	-1/-5	1	1	T1	-T-XXX-02-02-XXX	N/A	N/A	-T-XXX-01-02-XXX	N/A	-S-XXX-01-01-L	-S-XXX-02-01-L	N/A	N/A	-T-XXX-03-02-XXX		
		-2/-6	1	2	T1	-T-XXX-02-01-XXX	N/A	N/A	-T-XXX-01-01-XXX	N/A	-S-XXX-01-02-L	-S-XXX-02-02-L	N/A	N/A	-T-XXX-03-01-XXX		
		-3/-7	1	N-1	T1	N/A	-T-XXX-01-01-XXX	-T-XXX-02-01-XXX	N/A	-S-XXX-02-02-L	N/A	N/A	-S-XXX-01-02-L	-T-XXX-03-01-XXX	N/A		
		-4/-8	1	N	T1	N/A	-T-XXX-01-02-XXX	-T-XXX-02-02-XXX	N/A	-S-XXX-02-01-L	N/A	N/A	-S-XXX-01-01-L	-T-XXX-03-02-XXX	N/A		
-TTL	-T-XXX-02-01-XXX	-1/-5	1	1	B20	N/A	-T-XXX-01-01-XXX	-T-XXX-02-01-XXX	N/A	-S-XXX-02-01-L	N/A	N/A	-S-XXX-01-01-L	-T-XXX-03-02-XXX	N/A		
		-2/-6	1	2	B20	N/A	-T-XXX-01-01-XXX	-T-XXX-02-01-XXX	N/A	-S-XXX-02-02-L	N/A	N/A	-S-XXX-01-02-L	-T-XXX-03-01-XXX	N/A		
		-3/-7	1	N-1	B20	-T-XXX-02-01-XXX	N/A	N/A	-T-XXX-01-01-XXX	N/A	-S-XXX-01-02-L	-S-XXX-02-02-L	N/A	N/A	-T-XXX-03-01-XXX		
		-4/-8	1	N	B20	-T-XXX-02-02-XXX	N/A	N/A	-T-XXX-01-02-XXX	N/A	-S-XXX-01-01-L	-S-XXX-02-01-L	N/A	N/A	-T-XXX-03-02-XXX		
-TBR	-T-XXX-01-01-XXX	-1/-5	1	1	B20	N/A	-T-XXX-01-02-XXX	-T-XXX-02-02-XXX	N/A	-S-XXX-02-01-L	N/A	N/A	-S-XXX-01-01-L	-T-XXX-03-02-XXX	N/A		
		-2/-6	1	2	B20	N/A	-T-XXX-01-01-XXX	-T-XXX-02-01-XXX	N/A	-S-XXX-02-02-L	N/A	N/A	-S-XXX-01-02-L	-T-XXX-03-01-XXX	N/A		
		-3/-7	1	N-1	B20	-T-XXX-02-01-XXX	N/A	N/A	-T-XXX-01-01-XXX	N/A	-S-XXX-01-02-L	-S-XXX-02-02-L	N/A	N/A	-T-XXX-03-01-XXX		
		-4/-8	1	N	B20	-T-XXX-02-02-XXX	N/A	N/A	-T-XXX-01-02-XXX	N/A	-S-XXX-01-01-L	-S-XXX-02-01-L	N/A	N/A	-T-XXX-03-02-XXX		
-TBL	-T-XXX-02-01-XXX	-1/-5	1	1	T1	-T-XXX-02-02-XXX	N/A	N/A	-T-XXX-01-02-XXX	N/A	-S-XXX-01-01-L	-S-XXX-02-01-L	N/A	N/A	-T-XXX-03-02-XXX		
		-2/-6	1	2	T1	-T-XXX-02-01-XXX	N/A	N/A	-T-XXX-01-01-XXX	N/A	-S-XXX-01-02-L	-S-XXX-02-02-L	N/A	N/A	-T-XXX-03-01-XXX		
		-3/-7	1	N-1	T1	N/A	-T-XXX-01-01-XXX	-T-XXX-02-01-XXX	N/A	-S-XXX-02-02-L	N/A	N/A	-S-XXX-01-02-L	-T-XXX-03-01-XXX	N/A		
		-4/-8	1	N	T1	N/A	-T-XXX-01-02-XXX	-T-XXX-02-02-XXX	N/A	-S-XXX-02-01-L	N/A	N/A	-S-XXX-01-01-L	-T-XXX-03-02-XXX	N/A		
-STR	-S-XXX-01-01-L	-1/-5	1	1	T20	N/A	-T-XXX-01-01-XXX	-T-XXX-02-01-XXX	N/A	-S-XXX-02-02-L	N/A	N/A	-S-XXX-01-02-L	-T-XXX-03-01-XXX	N/A		
		-2/-6	1	2	T20	N/A	-T-XXX-01-02-XXX	-T-XXX-02-02-XXX	N/A	-S-XXX-02-01-L	N/A	N/A	-S-XXX-01-01-L	-T-XXX-03-02-XXX	N/A		
		-3/-7	1	N-1	T20	-T-XXX-02-02-XXX	N/A	N/A	-T-XXX-01-02-XXX	N/A	-S-XXX-01-01-L	-S-XXX-02-01-L	N/A	N/A	-T-XXX-03-02-XXX		
		-4/-8	1	N	T20	-T-XXX-02-01-XXX	N/A	N/A	-T-XXX-01-01-XXX	N/A	-S-XXX-01-02-L	-S-XXX-02-02-L	N/A	N/A	-T-XXX-03-01-XXX		
-STL	-S-XXX-02-01-L	-1/-5	1	1	B1	-T-XXX-02-01-XXX	N/A	N/A	-T-XXX-01-01-XXX	N/A	-S-XXX-01-02-L	-S-XXX-02-02-L	N/A	N/A	-T-XXX-03-01-XXX		
		-2/-6	1	2	B1	-T-XXX-02-02-XXX	N/A	N/A	-T-XXX-01-02-XXX	N/A	-S-XXX-01-01-L	-S-XXX-02-01-L	N/A	N/A	-T-XXX-03-02-XXX		
		-3/-7	1	N-1	B1	N/A	-T-XXX-01-02-XXX	-T-XXX-02-02-XXX	N/A	-S-XXX-02-01-L	N/A	N/A	-S-XXX-01-01-L	-T-XXX-03-02-XXX	N/A		
		-4/-8	1	N	B1	N/A	-T-XXX-01-01-XXX	-T-XXX-02-01-XXX	N/A	-S-XXX-02-02-L	N/A	N/A	-S-XXX-01-02-L	-T-XXX-03-01-XXX	N/A		
-SBR	-S-XXX-01-01-L	-1/-5	1	1	B1	-T-XXX-02-01-XXX	N/A	N/A	-T-XXX-01-01-XXX	N/A	-S-XXX-01-02-L	-S-XXX-02-02-L	N/A	N/A	-T-XXX-03-01-XXX		
		-2/-6	1	2	B1	-T-XXX-02-02-XXX	N/A	N/A	-T-XXX-01-02-XXX	N/A	-S-XXX-01-01-L	-S-XXX-02-01-L	N/A	N/A	-T-XXX-03-02-XXX		
		-3/-7	1	N-1	B1	N/A	-T-XXX-01-02-XXX	-T-XXX-02-02-XXX	N/A	-S-XXX-02-01-L	N/A	N/A	-S-XXX-01-01-L	-T-XXX-03-02-XXX	N/A		
		-4/-8	1	N	B1	N/A	-T-XXX-01-01-XXX	-T-XXX-02-01-XXX	N/A	-S-XXX-02-02-L	N/A	N/A	-S-XXX-01-02-L	-T-XXX-03-01-XXX	N/A		
-SBL	-S-XXX-02-01-L	-1/-5	1	1	T20	N/A	-T-XXX-01-01-XXX	-T-XXX-02-01-XXX	N/A	-S-XXX-02-01-L	N/A	N/A	-S-XXX-01-02-L	-T-XXX-03-01-XXX	N/A		
		-2/-6	1	2	T20	N/A	-T-XXX-01-02-XXX	-T-XXX-02-02-XXX	N/A	-S-XXX-02-01-L	N/A	N/A	-S-XXX-01-01-L	-T-XXX-03-02-XXX	N/A		
		-3/-7	1	N-1	T20	-T-XXX-02-02-XXX	N/A	N/A	-T-XXX-01-02-XXX	N/A	-S-XXX-01-01-L	-S-XXX-02-01-L	N/A	N/A	-T-XXX-03-02-XXX		
		-4/-8	1	N	T20	-T-XXX-02-01-XXX	N/A	N/A	-T-XXX-01-01-XXX	N/A	-S-XXX-01-02-L	-S-XXX-02-02-L	N/A	N/A	-T-XXX-03-01-XXX		
-TEU	-T-XXX-03-01-XXX	-1/-5	1	1	T1	-T-XXX-02-02-XXX	N/A	N/A	-T-XXX-01-02-XXX	N/A	-S-XXX-01-01-L	-S-XXX-02-01-L	N/A	N/A	-T-XXX-03-02-XXX		
		-2/-6	1	2	T1	-T-XXX-02-01-XXX	N/A	N/A	-T-XXX-01-01-XXX	N/A	-S-XXX-01-02-L	-S-XXX-02-02-L	N/A	N/A	-T-XXX-03-01-XXX		
		-3/-7	1	N-1	T1	N/A	-T-XXX-01-01-XXX	-T-XXX-02-01-XXX	N/A	-S-XXX-02-02-L	N/A	N/A	-S-XXX-01-02-L	-T-XXX-03-01-XXX	N/A		
		-4/-8	1	N	T1	N/A	-T-XXX-01-02-XXX	-T-XXX-02-02-XXX	N/A	-S-XXX-02-01-L	N/A	N/A	-S-XXX-01-01-L	-T-XXX-03-02-XXX	N/A		
-TED	-T-XXX-03-01-XXX	-1/-5	1	1	B20	N/A	-T-XXX-01-02-XXX	-T-XXX-02-02-XXX	N/A	-S-XXX-02-01-L	N/A	N/A	-S-XXX-01-01-L	-T-XXX-03-02-XXX	N/A		
		-2/-6	1	2	B20	N/A	-T-XXX-01-01-XXX	-T-XXX-02-01-XXX	N/A	-S-XXX-02-02-L	N/A	N/A	-S-XXX-01-02-L	-T-XXX-03-01-XXX	N/A		
		-3/-7	1	N-1	B20	-T-XXX-02-01-XXX	N/A	N/A	-T-XXX-01-01-XXX	N/A	-S-XXX-01-02-L	-S-XXX-02-02-L	N/A	N/A	-T-XXX-03-01-XXX		
		-4/-8	1	N	B20	-T-XXX-02-02-XXX	N/A	N/A	-T-XXX-01-02-XXX	N/A	-S-XXX-01-01-L	-S-XXX-02-01-L	N/A	N/A	-T-XXX-03-02-XXX		

TABLE 8											
DIFFERENTIAL PAIR PINOUT (DOES NOT ACCOUNT FOR CABLE WIRING OPTION)											
1	3	5	7	9	11	13	...	N-7	N-5	N-3	N-1
GND	DIFF PAIR		GND	DIFF PAIR		GND	...	GND	DIFF PAIR		GND
GND	DIFF PAIR		GND	DIFF PAIR		GND	...	GND	DIFF PAIR		GND
2	4	6	8	10	12	14	...	N-6	N-4	N-2	N

NOTE: CONNECTOR LATCHES ARE TIED TO GROUND
SQUEEZE LATCHES ARE NOT GROUND

<p>PROPRIETARY NOTE</p> <p>THIS DOCUMENT CONTAINS CONFIDENTIAL AND PROPRIETARY INFORMATION AND ALL DESIGN, MANUFACTURING, REPRODUCTION, USE, PATENT RIGHTS AND SALES RIGHTS ARE EXPRESSLY RESERVED BY SAMTEC, INC. THIS DOCUMENT SHALL NOT BE DISCLOSED, IN WHOLE OR PART, TO ANY UNAUTHORIZED PERSON OR ENTITY NOR REPRODUCED, TRANSFERRED OR INCORPORATED IN ANY OTHER PROJECT IN ANY MANNER WITHOUT THE EXPRESS WRITTEN CONSENT OF SAMTEC, INC.</p>	 <p>520 PARK EAST BLVD. NEW ALBANY, IN 47150 PHONE: 812-944-6733 FAX: 812-948-5047 e-Mail: info@SAMTEC.com code 55322</p>	
	<p>DO NOT SCALE DRAWING</p>	<p>DESCRIPTION: CUSTOM HDR CABLE ASSEMBLY</p>
	<p>SHEET SCALE: 1:1</p>	<p>DWG. NO. ERDP-XXX-XX.XX-XXX-XXX-X-X</p>
		<p>BY: J. BORGELT 1/21/2008 SHEET 6 OF 6</p>