

## Low voltage 0.5 $\Omega$ single SPDT switch with break-before-make feature and 15 kV contact ESD protection

Datasheet - production data

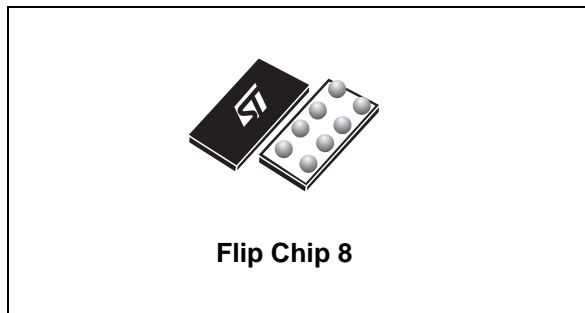

### Features

- Wide operating voltage range:  
 $V_{CC}$  (opr.) = 1.65 to 4.8 V
- Low power dissipation:  
 $I_{CC}$  = 0.2  $\mu$ A (max.) at  $T_A$  = 85 °C
- Low on-resistance:
  - $R_{ON}$  = 0.75  $\Omega$  ( $T_A$  = 25 °C) at  $V_{CC}$  = 2.25 V
  - $R_{ON}$  = 0.50  $\Omega$  ( $T_A$  = 25 °C) at  $V_{CC}$  = 3.0 V
  - $R_{ON}$  = 0.40  $\Omega$  ( $T_A$  = 25 °C) at  $V_{CC}$  = 4.3 V
- Separate supply voltage for switch and control pins
- Latch-up performance exceeds 100 mA per JESD 78, Class II
- ESD performance tested on common pin (D pin):
  - 15 kV IEC 61000-4-2 ESD, contact discharge
  - 8 kV HBM JESD22 A114-B Class II
- ESD performance tested on S1 and S2 pin: 8 kV IEC 61000-4-2 ESD, contact discharge
- ESD performance test on all other pins:
  - 4 kV HBM (JESD22 A114-B Class II)
  - 400 V machine model (JESD22 A115-A)
  - 1500 V charged-device model (JESD22 C101)

### Applications

- Mobile phones

### Description

The STG4160 device is a high-speed CMOS low voltage single analog SPDT (single pole dual throw) switch or 2:1 multiplexer/demultiplexer switch fabricated in silicon gate C<sup>2</sup>MOS technology. It is designed to operate from 1.65 to 4.8 V, making this device ideal for portable applications. It offers low on-resistance (0.40  $\Omega$  typ.) at  $V_{CC}$  = 4.3 V. The SEL inputs are provided to control the switches.

The switch S1 is ON (connected to the common port D) when the SEL input is held high and OFF (high impedance state exists between the two ports) when the SEL is held low. The switch S2 is ON (connected to the common port D) when the SEL input is held low and OFF (high impedance state exist between the two ports) when the SEL is held high.

Additional key features are fast switching speed, break-before-make delay time and ultra power consumption. All inputs and outputs are equipped with protection circuits against static discharge, giving them ESD immunity and transient excess voltage.

**Table 1. Device summary**

Order code	Package	Packing
STG4160BJR	Flip Chip 8	Tape and reel

# Contents

<b>1</b>	<b>Pin settings</b> .....	<b>3</b>
	1.1 Pin connections .....	3
	1.2 Pin description .....	3
<b>2</b>	<b>Logic diagram</b> .....	<b>4</b>
<b>3</b>	<b>Maximum ratings</b> .....	<b>5</b>
<b>4</b>	<b>Electrical characteristics</b> .....	<b>6</b>
<b>5</b>	<b>Test circuits</b> .....	<b>9</b>
<b>6</b>	<b>Package information</b> .....	<b>13</b>
<b>7</b>	<b>Package marking information</b> .....	<b>17</b>
<b>8</b>	<b>Revision history</b> .....	<b>18</b>



# 1 Pin settings

## 1.1 Pin connections

Figure 1. Pin connections

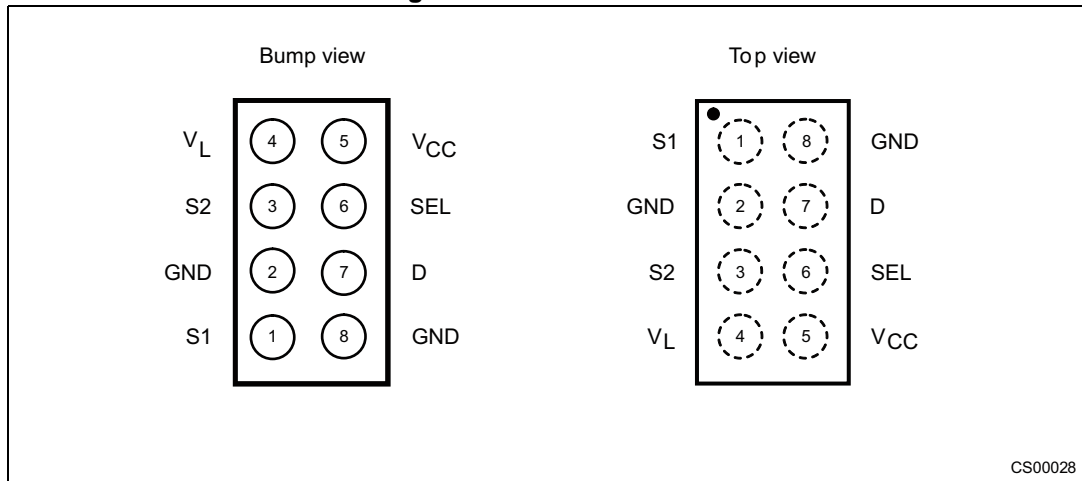

CS00028

## 1.2 Pin description

Table 2. Pin assignment

Pin number	Ball number	Symbol	Name and function
1	B1	S1	Independent channel
2	B2	GND	Ground (0 V)
3	B3	S2	Independent channel
4	B4	V <sub>L</sub>	Logic supply voltage
5	A4	V <sub>CC</sub>	Positive supply voltage
6	A3	SEL	Control
7	A2	D	Common channel
8	A1	GND	Ground (0 V)

## 2 Logic diagram

Figure 2. Functional diagram

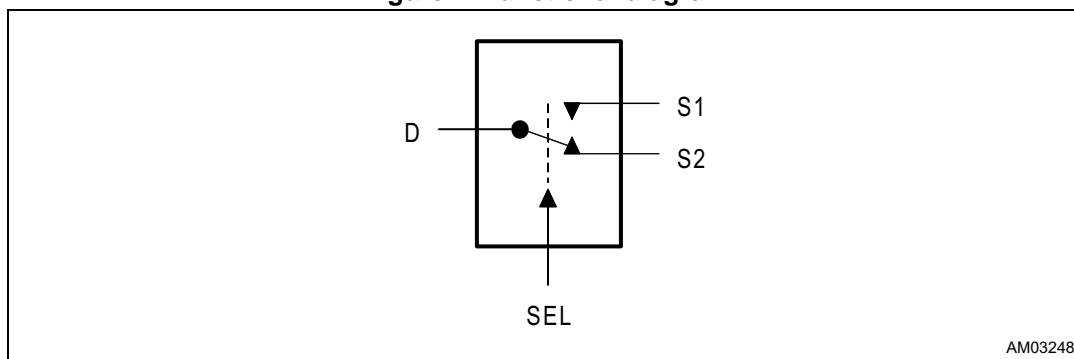

AM03248

Figure 3. Circuit equivalent logic

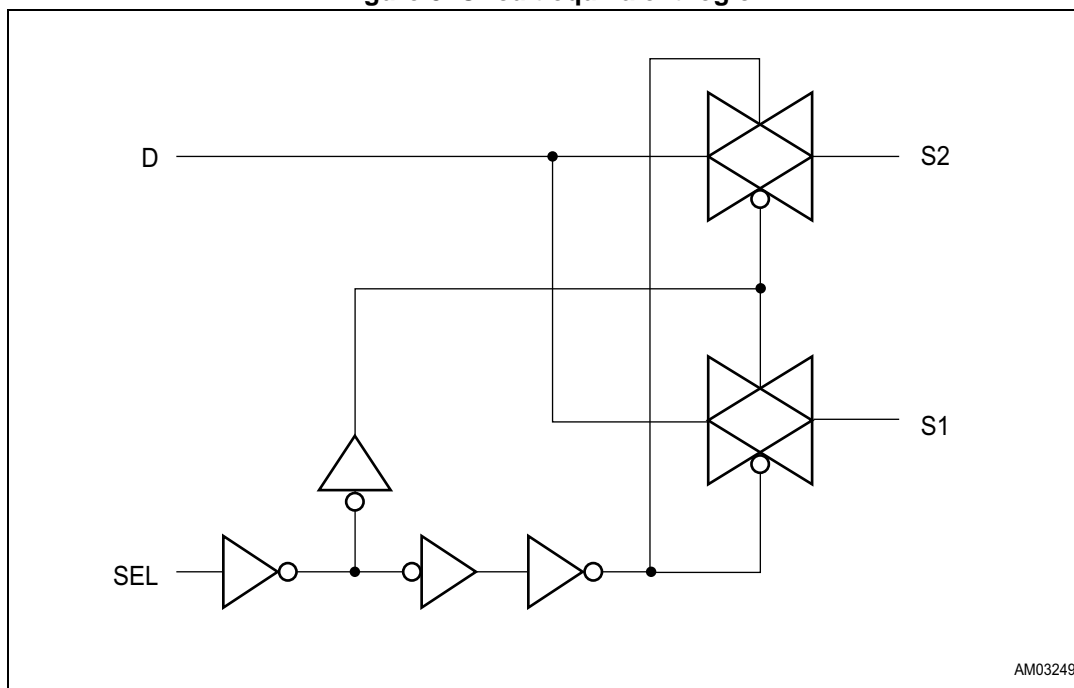

AM03249

Table 3. Truth table

SEL	Switch S1	Switch S2
H	ON	OFF <sup>(1)</sup>
L	OFF <sup>(1)</sup>	ON

1. High impedance.

### 3 Maximum ratings

Stressing the device above the rating listed in [Table 4: Absolute maximum ratings](#) may cause permanent damage to the device. These are stress ratings only and operation of the device at these or any other conditions above those indicated in [Table 5: Recommended operating conditions](#) of this specification is not implied. Exposure to absolute maximum rating conditions for extended periods may affect device reliability. Refer also to the STMicroelectronics® SURE program and other relevant quality documents.

**Table 4. Absolute maximum ratings**

Symbol	Parameter	Value	Unit
$V_{CC}$	Supply voltage	-0.5 to 5.5	V
$V_L$	Logic supply voltage	-0.5 to 5.5	V
$V_I$	DC input voltage	-0.5 to $V_{CC} + 0.5$	V
$V_{IC}$	DC control input voltage	-0.5 to $V_L + 5.5$	V
$V_O$	DC output voltage	-0.5 to $V_{CC} + 0.5$	V
$I_{IKC}$	DC input diode current on control pin ( $V_{SEL} < 0$ V)	- 50	mA
$I_{IK}$	DC input diode current ( $V_{SEL} < 0$ V)	$\pm 50$	mA
$I_{OK}$	DC output diode current	$\pm 20$	mA
$I_O$	DC output current	$\pm 300$	mA
$I_{OP}$	DC output current peak (pulse at 1 ms, 10% duty cycle)	$\pm 500$	mA
$I_{CC}$ or $I_{GND}$	DC $V_{CC}$ or ground current	$\pm 100$	mA
$P_D$	Power dissipation at $T_A = 70$ °C <sup>(1)</sup>	500	mW
$T_{stg}$	Storage temperature	-65 to 150	°C
$T_L$	Lead temperature (10 sec.)	260	°C

1. Derate above 70 °C by 18.5 mW/C.

**Table 5. Recommended operating conditions**

Symbol	Parameter	Value	Unit	
$V_{CC}$	Supply voltage	1.65 to 4.8	V	
$V_L$	Logic supply voltage <sup>(1)</sup>	1.65 to $V_{CC}$	V	
$V_I$	Input voltage	0 to $V_{CC}$	V	
$V_{IC}$	Control input voltage	0 to $V_L$	V	
$V_O$	Output voltage	0 to $V_{CC}$	V	
$T_{op}$	Operating temperature	-40 to 85	°C	
dt/dv	Input rise and fall time control input	$V_L = 1.65$ to $2.7$ V	0 to 20	ns/V
		$V_L = 3.0$ to $4.8$ V	0 to 10	

1.  $V_L$  pin should not be left floating.

## 4 Electrical characteristics

Table 6. DC specifications

Symbol	Parameter	V <sub>CC</sub> (V)	V <sub>L</sub> (V)	Test conditions	Value					Unit
					T <sub>A</sub> = 25 °C			-40 to 85 °C		
					Min.	Typ.	Max.	Min.	Max.	
V <sub>IH</sub>	High level input voltage	1.65 – 4.3	1.65 – 1.95		1.25			1.25		V
			2.3 – 2.7		1.75			1.75		
			3.0 – 3.6		2.34			2.34		
			4.3		2.80			2.80		
V <sub>IL</sub>	Low level input voltage	1.65 – 4.3	1.65 – 1.95				0.6		0.6	V
			2.3 – 2.7				0.8		0.8	
			3.0 – 3.6				1.05		1.05	
			4.3				1.5		1.5	
R <sub>ON</sub>	On-resistance	1.8	1.65 – 4.3	V <sub>S</sub> = 0 V to V <sub>CC</sub> I <sub>S</sub> = 100 mA		1.5	2.5		3.7	Ω
		2.25				0.75	1.0		1.3	
		3				0.50	0.65		0.8	
		3.7				0.45	0.55		0.7	
		4.3				0.40	0.5		0.65	
ΔR <sub>ON</sub>	On-resistance match between channels <sup>(1)</sup>	1.8	1.65 – 4.3	V <sub>S</sub> = 0 V to V <sub>CC</sub> I <sub>S</sub> = 100 mA		40				mΩ
		2.25				20				
		3				10				
		3.7				10				
		4.3				10				
R <sub>FLAT</sub>	On-resistance flatness <sup>(2)</sup>	1.8	1.65 – 4.3	V <sub>S</sub> = 0 V to V <sub>CC</sub> I <sub>S</sub> = 100 mA		1.0	1.7		2.0	mΩ
		2.25				300	430		550	
		3				150	190		270	
		3.7				140	180		230	
		4.3				140	180		220	
I <sub>OFF</sub>	Sn OFF state leakage current	4.3	4.3	V <sub>S</sub> = 0.3 to 4.0 V <sub>D</sub> = 0.3 to 4.0	-30		30	-300	300	nA
I <sub>ON</sub>	Sn ON state leakage current	4.3	4.3	V <sub>S</sub> = 0.3 to 4.0 V <sub>D</sub> = open	-30		30	-300	300	nA
I <sub>D</sub>	D ON state leakage current	4.3	4.3	V <sub>S</sub> = open V <sub>D</sub> = 0 to 4.0	-30		30	-300	300	nA

Table 6. DC specifications (continued)

Symbol	Parameter	V <sub>CC</sub> (V)	V <sub>L</sub> (V)	Test conditions	Value					Unit
					T <sub>A</sub> = 25 °C			-40 to 85 °C		
					Min.	Typ.	Max.	Min.	Max.	
I <sub>CC</sub>	Quiescent supply current	1.65 – 4.3	1.65 – 4.3	V <sub>SEL</sub> = V <sub>CC</sub> or GND	-0.05		0.05	-0.2	0.2	μA
I <sub>SEL</sub>	SEL leakage current	1.65 – 4.3	1.65 – 4.3	V <sub>SEL</sub> = 4.3V or GND	-0.2		0.2	-2	2	μA

1.  $\Delta R_{ON} = R_{ON(Max)} - R_{ON(Min)}$

2. Flatness is defined as the difference between the maximum and minimum value of on-resistance as measured over the specified analog signal ranges.

Table 7. AC electrical characteristics (C<sub>L</sub> = 35 pF, R<sub>L</sub> = 50 Ω, t<sub>r</sub> = t<sub>f</sub> ≤ 5 ns)

Symbol	Parameter	Test conditions			Value					Unit
		V <sub>CC</sub> (V)	V <sub>L</sub> (V)		T <sub>A</sub> = 25 °C			-40 to 85 °C		
					Min.	Typ.	Max.	Min.	Max.	
t <sub>PLH</sub> , t <sub>PHL</sub>	Propagation delay	1.65 – 1.95	1.65 – 4.3			0.18				ns
		2.3 – 2.7				0.14				
		3.0 – 3.3				0.12				
		3.6 – 4.3				0.12				
t <sub>ON</sub>	Turn-on time	1.65 – 1.95	1.65 – 4.3	V <sub>S</sub> = V <sub>CC</sub> R <sub>L</sub> = 50 Ω C <sub>L</sub> = 30 pF		70	123		160	ns
		2.3 – 2.7				48	62		80	
		3 – 3.6				33	43		56	
		4.3				29	38		49	
t <sub>OFF</sub>	Turn-off time	1.65 – 1.95	1.65 – 4.3	V <sub>S</sub> = V <sub>CC</sub> R <sub>L</sub> = 50 Ω C <sub>L</sub> = 30 pF		36	45		60	ns
		2.3 – 2.7				35	47		62	
		3 – 3.6				30	40		51	
		4.3				29	38		50	
t <sub>D</sub>	Break-before-make time delay	1.65 – 1.95	1.65 – 4.3	C <sub>L</sub> = 35 pF R <sub>L</sub> = 50 Ω V <sub>S</sub> = V <sub>CC</sub> /2	10	42				ns
		2.3 – 2.7			10	22				
		3 – 3.6			5	15				
		4.3			5	12				
Q	Charge injection	1.65 – 1.95	1.65 – 4.3	C <sub>L</sub> = 1 nF V <sub>GEN</sub> = 0 V		75				pC
		2.3 – 2.7				98				
		3.0 – 3.3				133				
		3.6 – 4.3				162				

**Table 7. AC electrical characteristics ( $C_L = 35 \text{ pF}$ ,  $R_L = 50 \text{ } \Omega$ ,  $t_r = t_f \leq 5 \text{ ns}$ ) (continued)**

Symbol	Parameter	Test conditions			Value					Unit
		$V_{CC}$ (V)	$V_L$ (V)		$T_A = 25 \text{ } ^\circ\text{C}$			$-40 \text{ to } 85 \text{ } ^\circ\text{C}$		
					Min.	Typ.	Max.	Min.	Max.	
OIRR	OFF-isolation <sup>(1)</sup>	1.65 – 4.3	4.3	$V_S = 1 V_{RMS}$ $f = 100 \text{ kHz}$		77				dB
				$V_S = 1 V_{RMS}$ $f = 1 \text{ MHz}$		67				
				$V_S = 1 V_{RMS}$ $f = 5 \text{ MHz}$		50				
Xtalk	Crosstalk	1.65 – 4.3	4.3	$V_S = 1 V_{RMS}$ $f = 100 \text{ kHz}$		80				dB
				$V_S = 1 V_{RMS}$ $f = 1 \text{ MHz}$		67				
				$V_S = 1 V_{RMS}$ $f = 5 \text{ MHz}$		50				
THD	Total harmonic distortion	2.3 – 4.3	4.3	$R_L = 600 \text{ } \Omega$ $C_L = 50 \text{ pF}$ $V_S = V_{CC}$ $f = 600 \text{ Hz to } 20 \text{ kHz}$		0.01				%
BW	-3 dB Bandwidth (switch ON)	1.65 – 4.3	4.3	$R_L = 50 \text{ } \Omega$		50				MHz

1. OFF-isolation =  $20 \log_{10} (V_D/V_S)$ ,  $V_D$  = output,  $V_S$  = input to off switch.

**Table 8. Capacitive characteristics**

Symbol	Parameter	Test conditions			Value					Unit
		$V_{CC}$ (V)	$V_L$ (V)		$T_A = 25 \text{ } ^\circ\text{C}$			$-40 \text{ to } 85 \text{ } ^\circ\text{C}$		
					Min.	Typ.	Max.	Min.	Max.	
$C_{SEL}$	Control pin input capacitance	1.8 – 4.3	1.8 – 4.3	$V_L = V_{CC}$		30				pF
$C_{SN}$	Sn port capacitance	1.8 – 4.3	1.8 – 4.3	$V_L = V_{CC}$		94				pF
$C_D$	D port capacitance when the switch is enabled	1.8 – 4.3	1.8 – 4.3	$V_L = V_{CC}$		227				pF



# 5 Test circuits

Figure 4. On-resistance

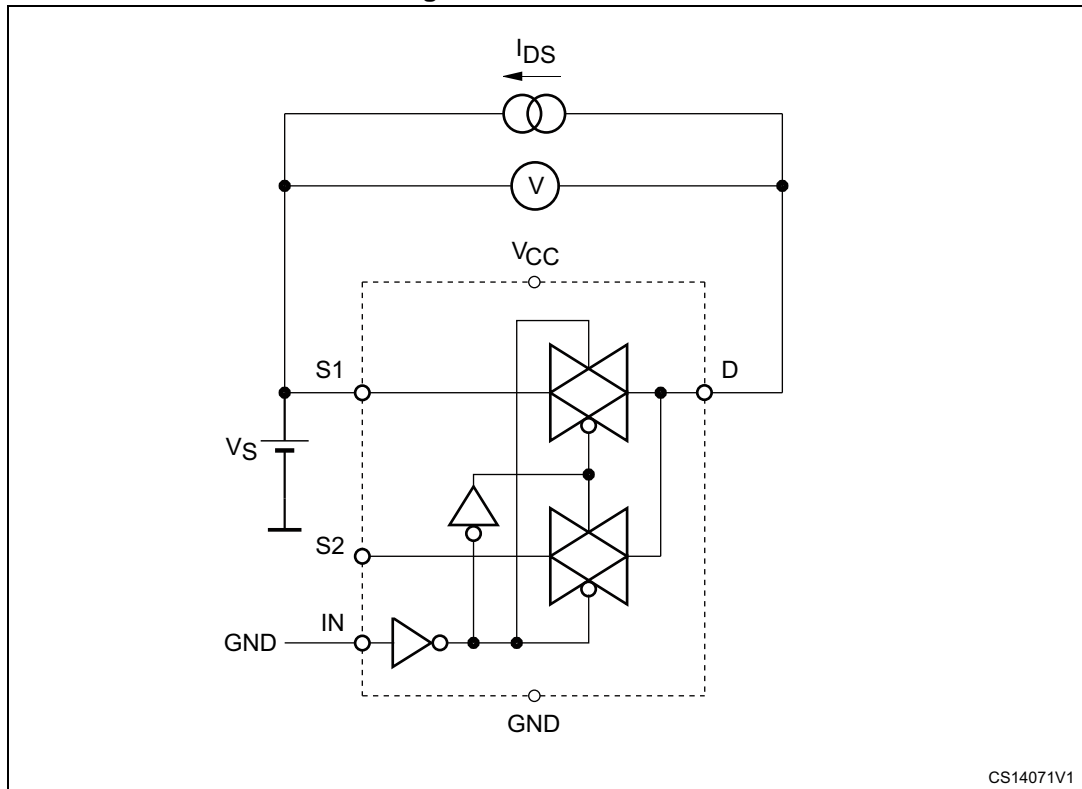

Figure 5. Bandwidth

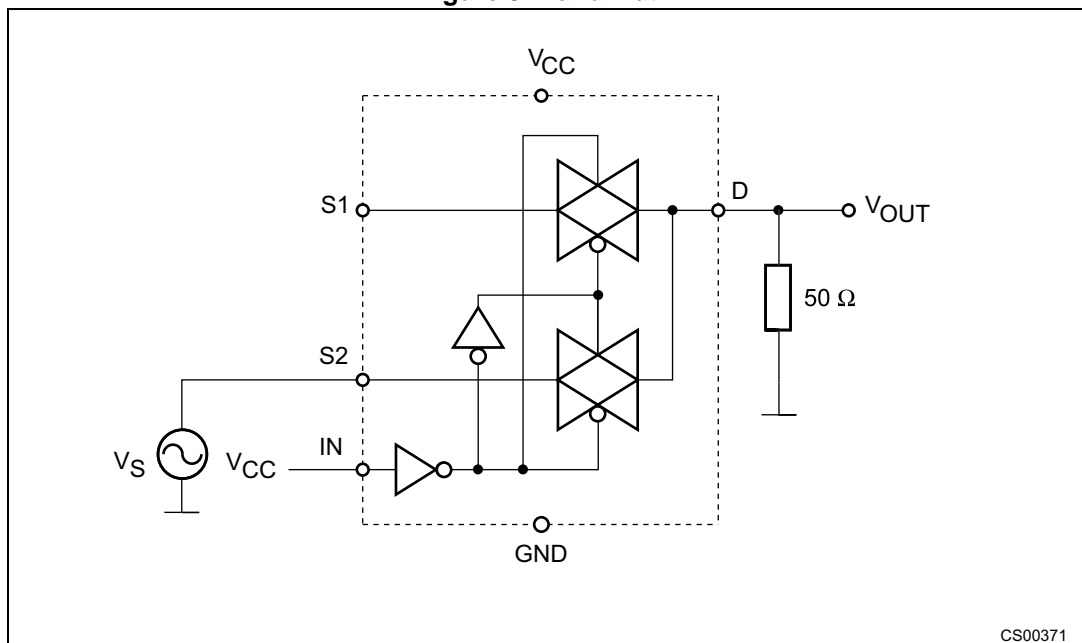

Figure 6. OFF-leakage

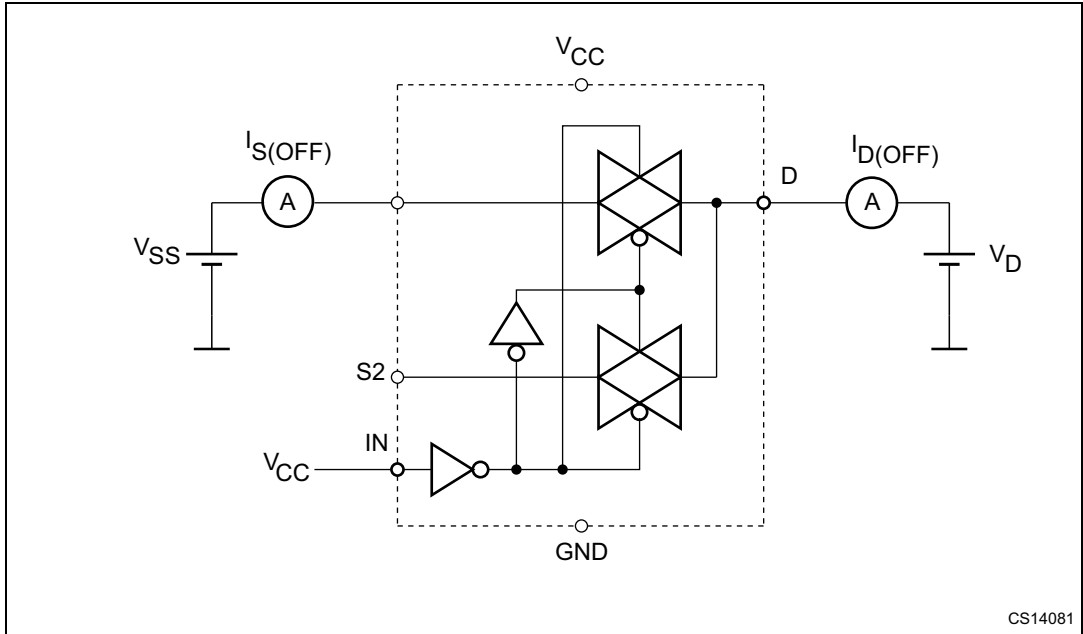

Figure 7. Channel-to-channel crosstalk

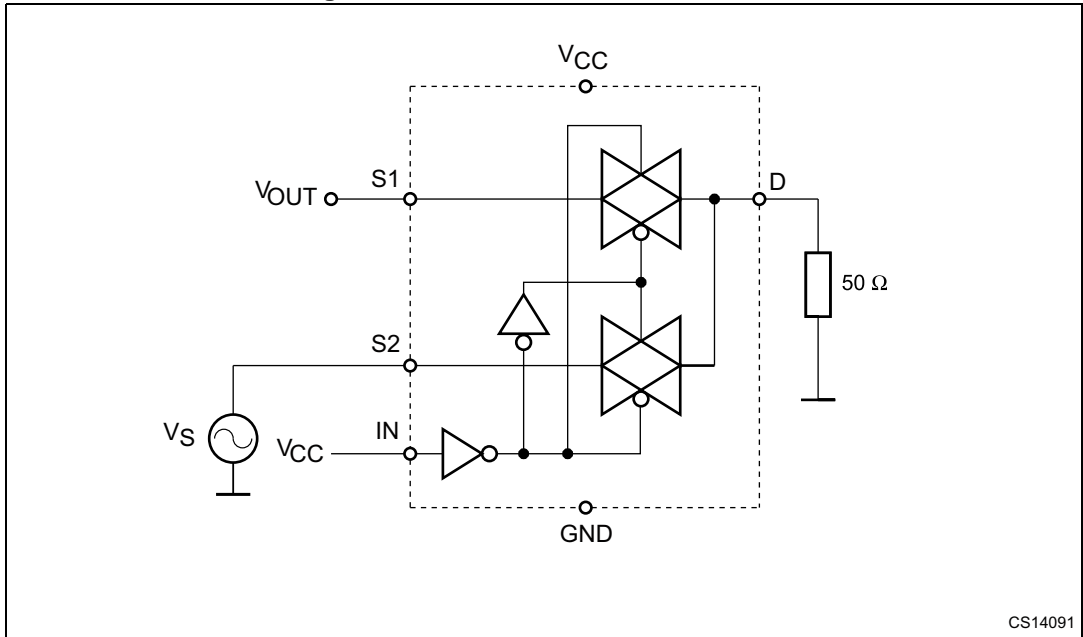
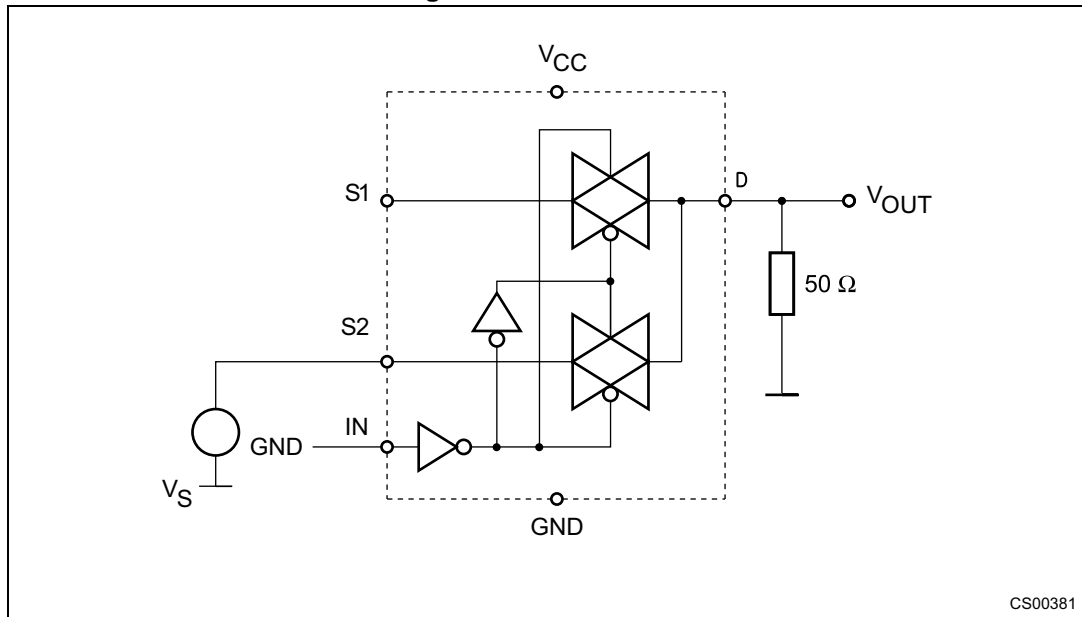
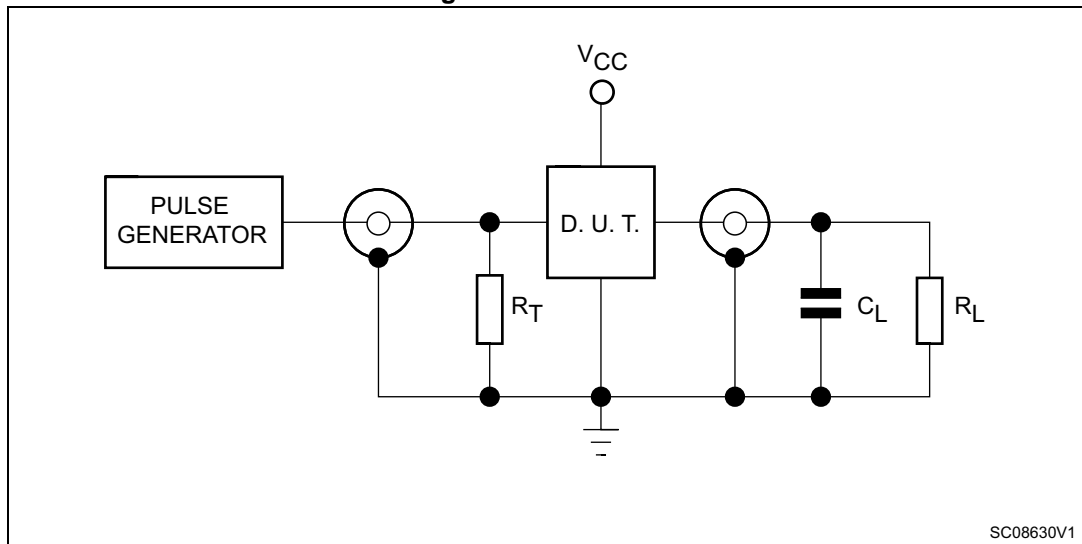

Figure 8. OFF-isolation



CS00381

Figure 9. Test circuit



SC08630V1

1.  $C_L = 5/35\ \text{pF}$  or equivalent (includes jig capacitance).
2.  $R_L = 50\ \Omega$  or equivalent.
3.  $R_T = Z_{OUT}$  of pulse generator (typically  $50\ \Omega$ ).

Figure 10. Break-before-make time delay

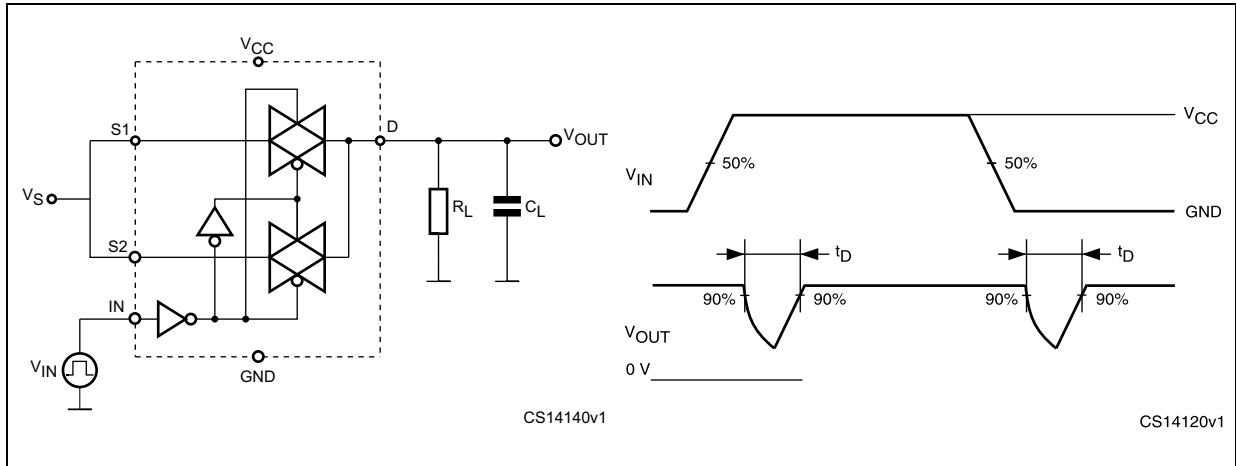

Figure 11. Switching time and charge injection (V<sub>GEN</sub> = 0 V, R<sub>GEN</sub> = 0 Ω, R<sub>L</sub> = 1 MΩ, C<sub>L</sub> = 100 pF)

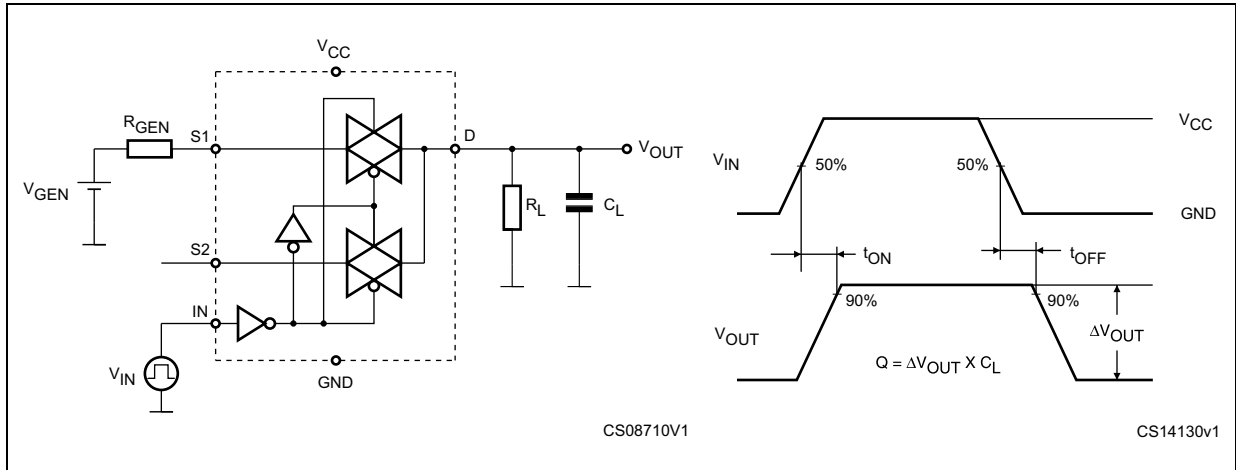
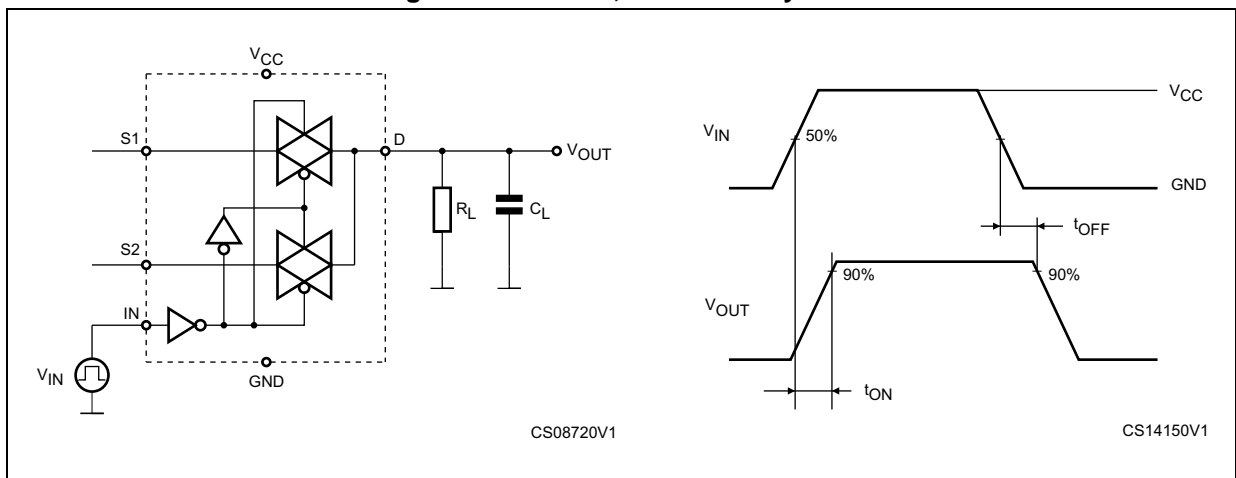

Figure 12. Turn-on, turn-off delay time



## 6 Package information

In order to meet environmental requirements, ST offers these devices in different grades of ECOPACK packages, depending on their level of environmental compliance. ECOPACK specifications, grade definitions and product status are available at: [www.st.com](http://www.st.com). ECOPACK is an ST trademark.

Figure 13. Flip Chip 8 package outline

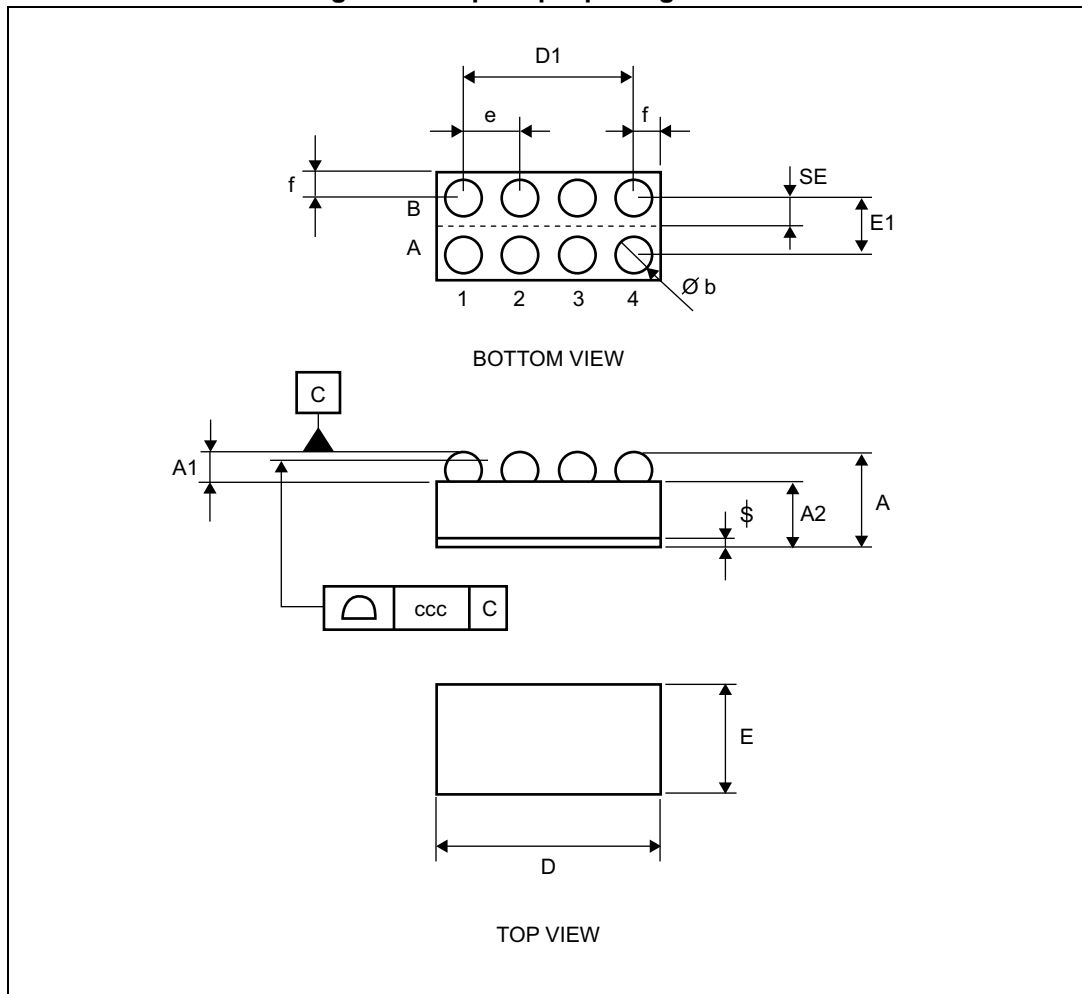

1. Drawing is not to scale.

Table 9. Flip Chip 8 mechanical data

Symbol	Dimensions (mm)		
	Min.	Typ.	Max.
A	0.535	0.58	0.625
A1	0.18	0.205	0.23
A2	0.355	0.375	0.395
b	0.215	0.255	0.295
D	1.85	1.9	1.95
D1		1.5	
e	0.45	0.5	0.55
E	0.85	0.9	0.95
E1	0.45	0.5	0.55
SE		0.25	
f	0.19	0.2	0.21
ccc		0.08	

Figure 14. Flip Chip 8 footprint

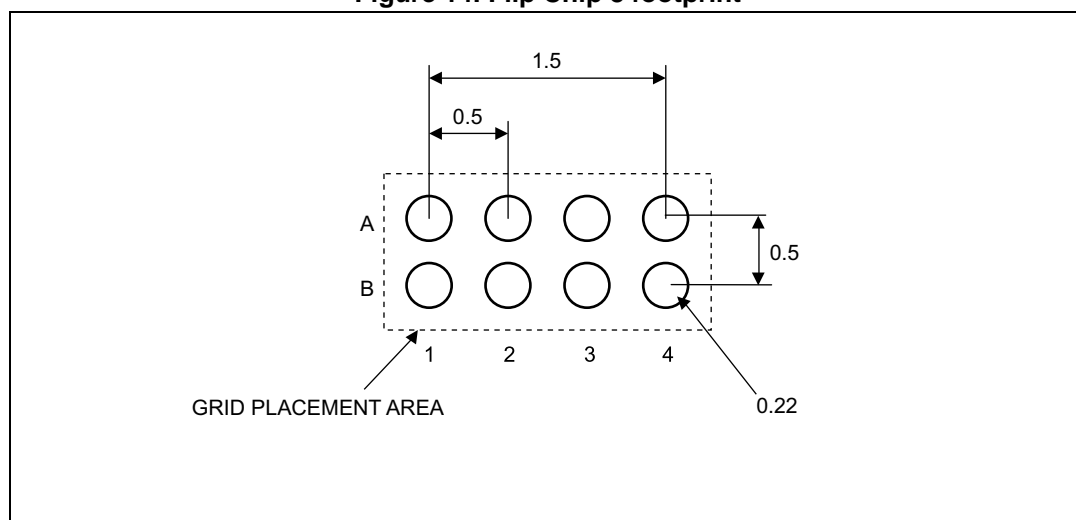

Figure 15. Flip Chip 8 tape and reel

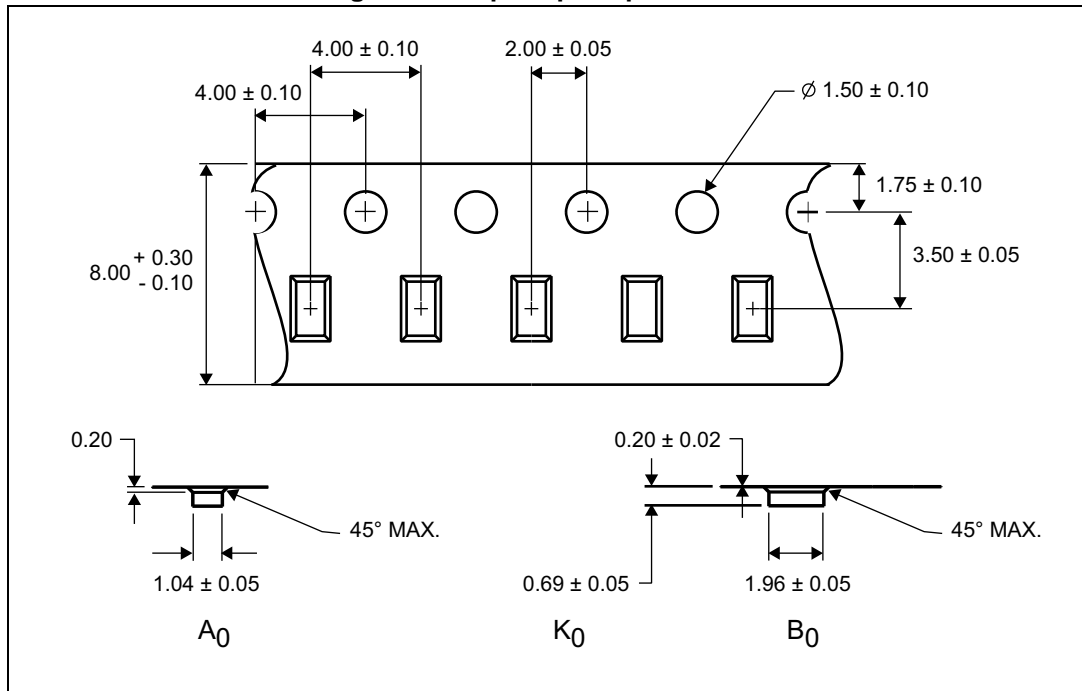

Figure 16. Tape orientation

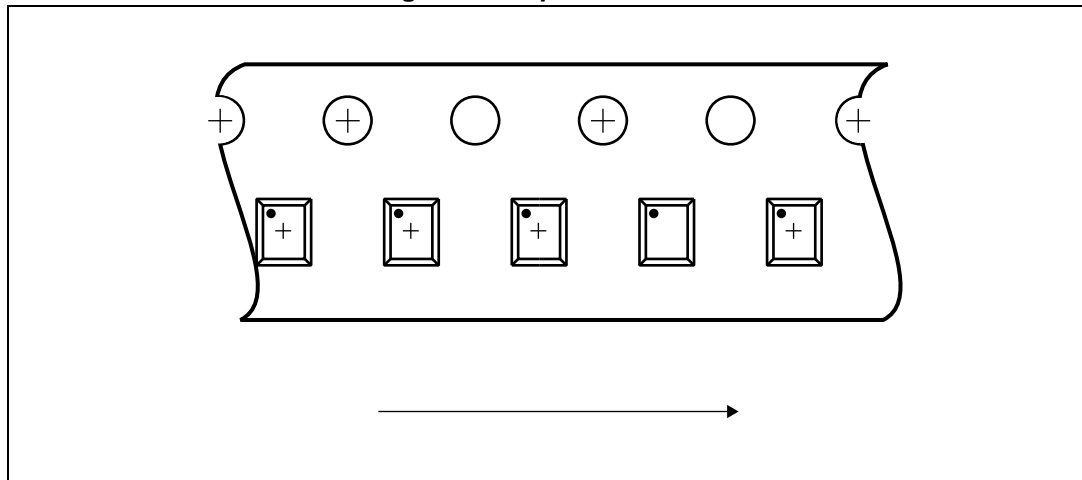
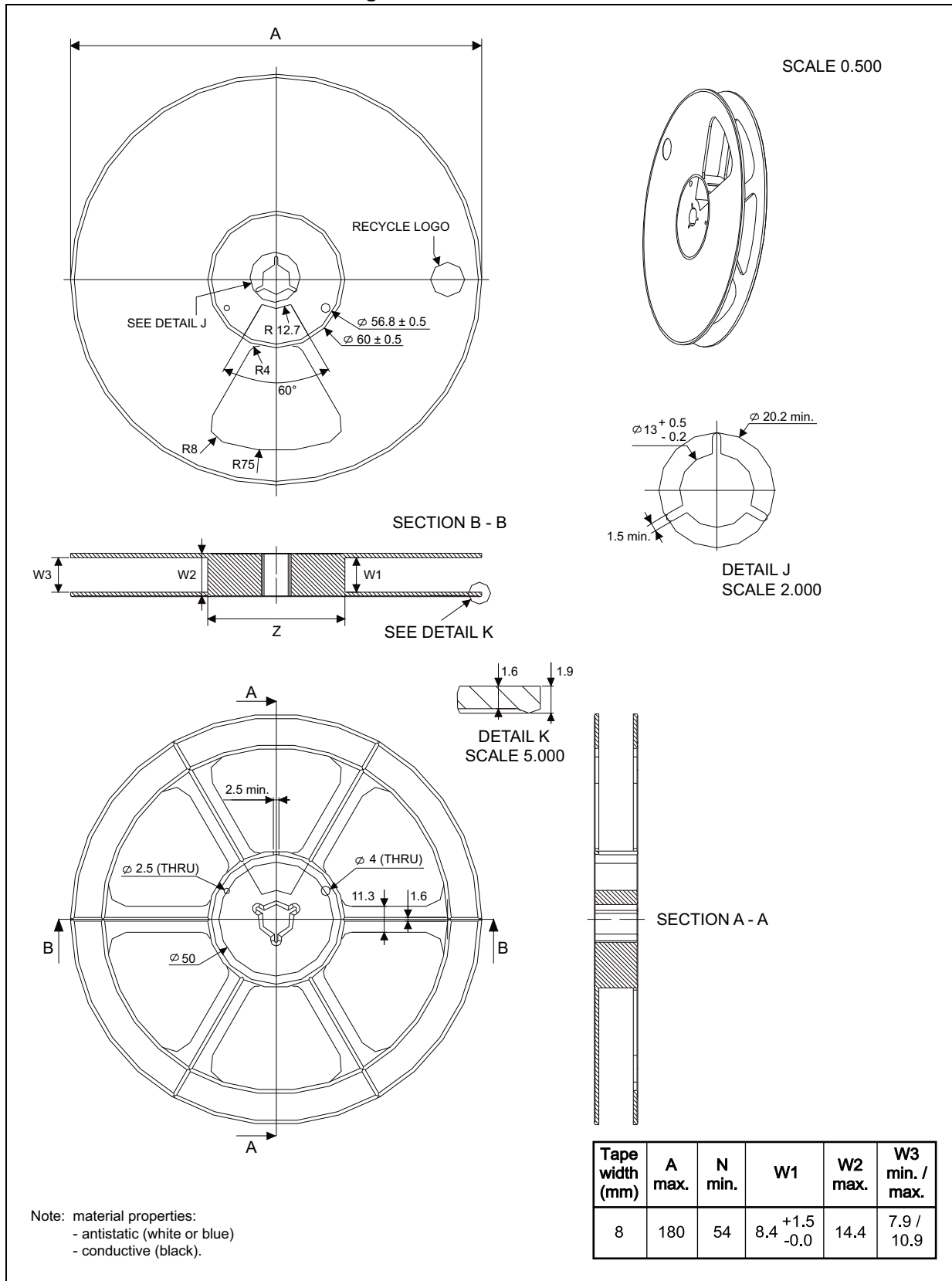

Figure 17. Reel information





## 7 Package marking information

Table 10. Device topside marking information

Marking composition: Flip Chip 8	
Package face: top	Legend
	<p> <span style="display: inline-block; width: 10px; height: 10px; background-color: black; margin-right: 5px;"></span> Unmarkable surface  <span style="display: inline-block; width: 10px; height: 10px; border: 1px solid black; margin-right: 5px;"></span> Marking composition field                 </p> <p>                     A - 53312 - dot                      B - 53313 - standard ST logo (000093)                      C - 53323 - ECO level                      D - 53314 - marking area                      E - 53318 - additional information (max. char. allowed = 1)                      F - 53319 - Assembly year (Y)                      G - 53322 - Assembly week (WW)                 </p>

## 8 Revision history

**Table 11. Document revision history**

Date	Revision	Changes
11-Sep-2008	1	Initial release.
19-Feb-2009	2	Updated: I <sub>ON</sub> values in <a href="#">Table 6: DC specifications</a> .
15-May-2013	3	Slightly redrawn <a href="#">Figure 3</a> to <a href="#">Figure 15</a> and <a href="#">Figure 17</a> . Updated <a href="#">Figure 16</a> (added "Dot identifying bump A1 location"). Updated <a href="#">Section 3: Maximum ratings</a> (added cross-references). Corrected units in <a href="#">Table 8</a> . Updated <a href="#">Section 6: Package mechanical data</a> (updated ECOPACK text). Added <a href="#">Section 7: Package marking information</a> . Minor corrections throughout document.
18-Jul-2022	4	Updated <a href="#">Table 2: Pin assignment</a>

**IMPORTANT NOTICE – PLEASE READ CAREFULLY**

STMicroelectronics NV and its subsidiaries (“ST”) reserve the right to make changes, corrections, enhancements, modifications, and improvements to ST products and/or to this document at any time without notice. Purchasers should obtain the latest relevant information on ST products before placing orders. ST products are sold pursuant to ST’s terms and conditions of sale in place at the time of order acknowledgement.

Purchasers are solely responsible for the choice, selection, and use of ST products and ST assumes no liability for application assistance or the design of Purchasers’ products.

No license, express or implied, to any intellectual property right is granted by ST herein.

Resale of ST products with provisions different from the information set forth herein shall void any warranty granted by ST for such product.

ST and the ST logo are trademarks of ST. For additional information about ST trademarks, please refer to [www.st.com/trademarks](http://www.st.com/trademarks). All other product or service names are the property of their respective owners.

Information in this document supersedes and replaces information previously supplied in any prior versions of this document.

© 2022 STMicroelectronics – All rights reserved