

14 A Active EMI Filter SIP for 48 Vdc Bus

Description:

The QPI-6 active EMI filter attenuates conducted common-mode (CM) and differential-mode (DM) noise over the CISPR22 frequency range of 150 kHz to 30 MHz. The product is designed for use on 48 Vdc bus (36 – 76 Vdc) systems, with 100 Vdc surge capability. The QPI-6's 14 A rating supports multiple DC-DC converter loads up to an ambient temperature of 65°C without de-rating. Designed for the telecom and ITE bus range, the QPI-6 supports the PICMG® 3.0 specification for filtering system boards to the EN55022 Class B limits.

In comparison to passive solutions, the use of active filtering reduces the volume of the common-mode choke, providing a low profile, surface mount device. Smaller size saves valuable board real estate and the reduced height enhances airflow in blade applications.

The QPI-6 is available as a lidded or an open-frame SiP (System-in-Package) with LGA mounting. Evaluation boards are available to allow for quick in-circuit testing of the QPI-6LZ within an existing system design.



Figure 1 - QPI-6LZ (~1 in² area)

Features:

- 40 dB CM attenuation at 250 KHz (50Ω)
- 80 dB DM attenuation at 250 KHz (50Ω)
- 80 Vdc (max input)
- 100 Vdc surge 100 ms
- 1,500 Vdc hipot hold off to shield plane
- 14 A rating
- 25.3 x 25.3 x 5.0 mm Lidded SiP (System-in-Package)
- 24.9 x 24.9 x 4.4 mm Open-frame SiP
- Low profile LGA package
- -40° to +125°C Ambient temperature (see Figure 12)
- Efficiency >99%
- Connect in series for higher attenuation
- TÜV Certified

Applications

- ATCA blades
- Telecom base stations
- IBA & distributed power
- Network switches and routers
- Optical line-cards
- TD-SCMA wireless infrastructure

Typical Application:

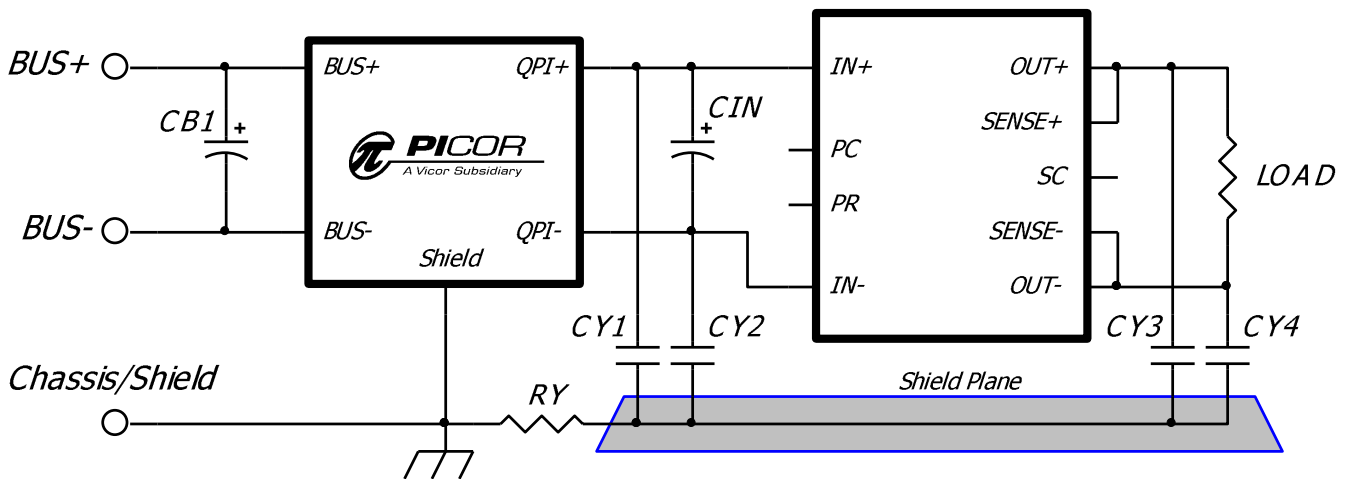

Figure 2 – Typical QPI-6 application schematic with a Vicor brick converter. ⁽¹⁾

Note 1: CB1 capacitor, referenced in all schematics, is a 47μF electrolytic; United Chemi-Con EMVE101ARA470MKE0S or equivalent.
CY1 to CY4, referenced in all schematics, are 4.7nF hi-voltage safety capacitors; Vishay VY1472M63YSUQ63V0 or equivalent.
CIN is the manufacturer's recommended value for input capacitor.

Absolute Maximum Ratings – Exceeding these parameters may result in permanent damage to the product.

Input Voltage, BUS+ to BUS-, continuous	-80 to 80 Vdc
Input Voltage, BUS+ to BUS-, 100ms transient	-100 to 100 Vdc
BUS+/ BUS- to Shield pads, hi-pot	-1500 to 1500 Vdc
Input to output current, continuous @ 25°C T _A	14 Adc
Input to output current, 10 seconds @ 25°C T _A	20 Adc
Power dissipation, @ 65°C T _A , 14 A ⁽²⁾	2.3 W
Operating temperature - T _A	-40 to 125 °C
Thermal resistance ⁽²⁾ - R _{θ-Av} using PCB layout in Figure 24	20 °C/W
Thermal resistance ⁽²⁾ - R _{θ-PCB}	8 °C/W
Storage temperature, JEDEC Standard J-STD-033B	-55 to 125 °C
Reflow temperature, 20 s exposure	245 °C
ESD, Human body model (HBM)	-2000 to 2000 V

Electrical Characteristics – Parameter limits apply over the operating temp. range, unless otherwise noted.

Parameter	Notes	Min	Typ	Max	Units
BUS+ to BUS- input range	Measured at 14 A, 65°C ambient temperature ⁽²⁾	30		80	Vdc
BUS+ to QPI+ voltage drop	Measured at 14 A, 65°C ambient temperature ⁽²⁾			135	mVdc
BUS- to QPI- voltage drop	Measured at 14 A, 65°C ambient temperature ⁽²⁾			29	mVdc
Common mode attenuation	VBUS = 48 V, Frequency = 250 KHz, line impedance = 50Ω		40		dB
Differential mode attenuation	VBUS = 48 V, Frequency = 250 KHz, line impedance = 50Ω		80		dB
Input bias current at 80 V	Input current from BUS+ to BUS-		8		mA

Note 2: See Figure 12 for the current de-rating curve.

Pad Descriptions

Pad Number	Name	Description	LGA Pattern (Top View)
12, 13, 14	BUS+	Positive bus potential	
1, 15, 16	BUS-	Negative bus potential	
7, 8, 9	QPI+	Positive input to the converter	
2, 3, 4	QPI-	Negative input to the converter	
5, 6	Shield	Shield connects to the system chassis or to a safety ground.	
10	THERM1	These pads are electrically isolated from the internal circuitry of the QPI-6. Either connecting THERM1 to QPI+ and THERM2 to BUS+, or to copper region(s) not connected to Shield, is recommended to help with thermal management.	
11	THERM2		

Ordering Information

Part Number	Description
QPI-6LZ ⁽³⁾	QPI-6 LGA Package, RoHS Compliant
QPI-6LZ-01	QPI-6 LGA Package, RoHS Compliant, Open Frame Package

Note 3: QPI-6LZ is a non-hermetically sealed package. Please read the "Post Solder Cleaning" section on page 12.

QPI-6 Evaluation Boards

Part #	Description:
QPI-6-EVAL1	A QPI-6LZ mounted on a small evaluation board with screw terminal blocks to allow for easy connection into an existing system.
QPI-6-CB1	A QPI-6LZ mounted on a carrier board designed for use with DOSA compliant footprint dc-dc converters. Screw terminal blocks to allow for easy connection into an existing system.

Applications Information

EMI Sources

Many of the components in today's power conversion modules are sources of high-frequency EMI noise generation. Diodes, high-frequency switching devices, transformers and inductors, and circuit layouts passing high dv/dt or di/dt signals are all potential sources of EMI.

EMI is propagated either by radiated or conductive means. Radiated EMI can be sourced from these components as well as by circuit loops that act like antennas and broadcast the noise signals to neighboring circuit paths. This also means that these loops can act as receivers of a broadcasted signal. This radiated EMI noise can be reduced by proper circuit layout and by shielding potential sources of EMI transmission.

There are two basic forms of conducted EMI that typically need to be filtered; namely common-mode (CM) and differential-mode (DM) EMI. Differential-mode resides in the normal power loop of a power source and its load; where the signal travels from the source to the load and then returns to the source. Common-mode is a signal that travels through both leads of the source and is returned to earth via parasitic pathways, either capacitively or inductively coupled.

Figure 8 to Figure 11 are the resulting EMI plots, after filtering by the QPI-6, of the total noise, both common and differential mode, of a Vicor Brick and a DOSA (Distributed-power Open Standards Alliance) compliant converter. These converters are mounted on a QPI-6 evaluation board and tested under various loads. The red and blue traces represent the positive and negative branches of total noise, as measured using an industry standard LISN setup, as is shown in Figures 6 and 7.

Differential-mode EMI is typically larger in magnitude than common-mode, since common-mode is produced by the physical imbalances in the differential loop path. Reducing differential EMI will cause a reduction in common-mode EMI.

Passive EMI Filtering

The basic premise of filtering EMI is to insert a high-impedance, at the EMI's base frequency, in both the differential and common-mode paths as it returns to the power source.

Passive filters use common-mode chokes and "Y" capacitors to filter out common-mode EMI. These chokes are designed to present a high-impedance at the EMI frequency in series with the return path, and a low impedance path to the earth signal via the "Y" caps. This network will force the EMI signals to re-circulate within a confined area and not to propagate to the outside world. Often two common-mode networks are required to filter EMI within the frequency span required to

pass the EN55022 class B limits.

The other component of the passive filter is the differential LC network. Again, the inductor is chosen such that it will present a high-impedance in the differential EMI loop at the EMI's base frequency. The differential capacitor will then shunt the EMI back to its source. The QPI-6 was specifically designed to work with conventional switching frequency converters like Vicor's Brick products; Micro, Mini and Maxi modules; as well as converters from various vendors.

Active EMI Filtering

PICOR's QPI-6 active EMI filter uses the same basic principles for filtering as the passive approach, but its active common-mode filter can perform as well as a passive filter, when filtering lower frequencies, in much less board area.

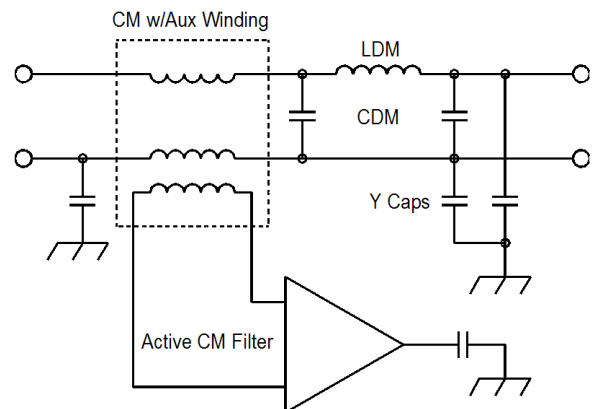

Figure 3 – Simplified Active EMI filter circuit.

Typically, the lower the frequency the greater the needed inductance would be to properly filter the EMI signal. This means either a larger core or a greater number of turns on a smaller core. A larger core requires more board space, where a smaller core with more turns has a greater amount of unwanted parasitics that can affect the filters ability to attenuate EMI signals.

Figure 3 is a simplified schematic of the QPI-6's active and passive circuitry used for EMI filtering. The QPI-6's active filter uses a small high-frequency common-mode transformer to filter the higher frequencies and adds a sensing element to it so that the lower frequency common mode signal can be sensed and a correction signal can be generated and inserted into the shield connection. By this means, the QPI-6 is capable of providing EMI filtering of converters in far less space than standard passive filters and can provide filtering over the entire EN55022 class B range.

EMI Management

The more effectively EMI is managed at the source, namely the power converter, the less EMI attenuation the filter will have to do. The addition of “Y” capacitors to the input and output power nodes of the converter will help to limit the amount of EMI that will propagate to the input source.

favor one topology versus another. The EMI generated by the “base-plate” configuration is much greater than that generated by the “open-frame”. Selecting the right topology will greatly reduce the amount of EMI signal that needs to be filtered.

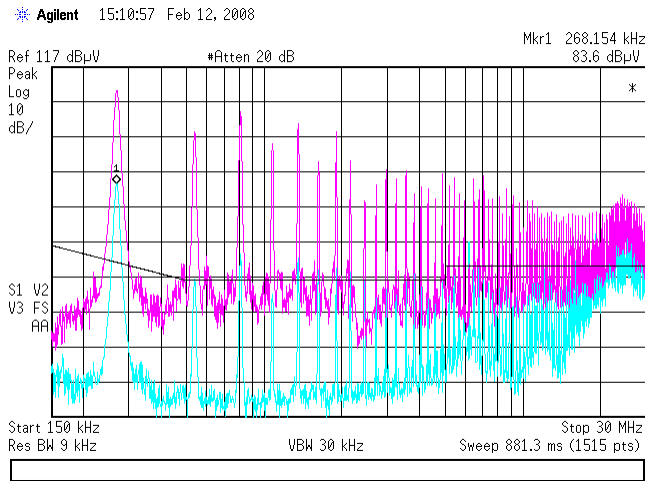

Figure 4 – An unfiltered converter’s response to “open-frame” (light blue) and “base-plate” (purple) EMI configurations.

There are two basic topologies for the connection of the re-circulating “Y” capacitors, referred to as “open-frame” and “base-plate”. Figure 4 illustrates how a converter can

Figure 2 shows the base-plate topology of re-circulating “Y” caps. Here, CY1 to CY4 are connected to each power node of the dc-dc converter, and then are commoned together on a copper shield plane created under the converter. The addition of the copper shield plane helps in the containment of the radiated EMI, converting it back to conducted EMI and shunting it back to its source.

The RY resistor, connected between the shield plane and the QPI’s shield pin, provides an impedance that makes the QPI’s common mode noise cancellation signal more effective at removing the common mode noise that would normally return to the shield/earth connection. It is important when laying out the QPI that the RY resistor connects to the QPI’s shield pin before making the connection to earth ground.

In Figure 5, the open-frame topology is shown where the “Y” capacitors (CY1 and CY2) re-circulate the EMI signals between the positive input and output, and the negative input and output nodes of the power conversion stage.

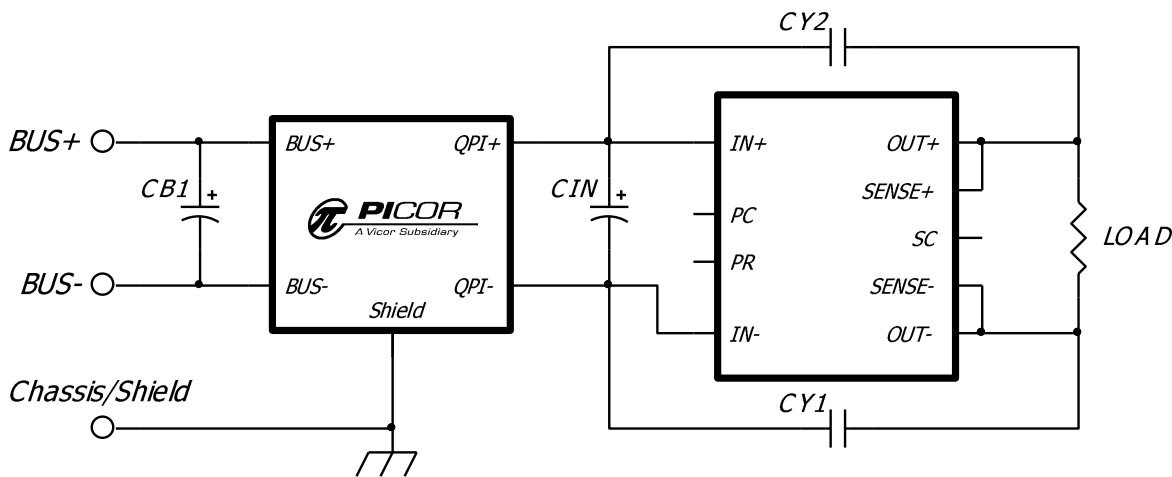

Figure 5 - Typical ‘open-frame’ application.

Attenuation Test Setups:

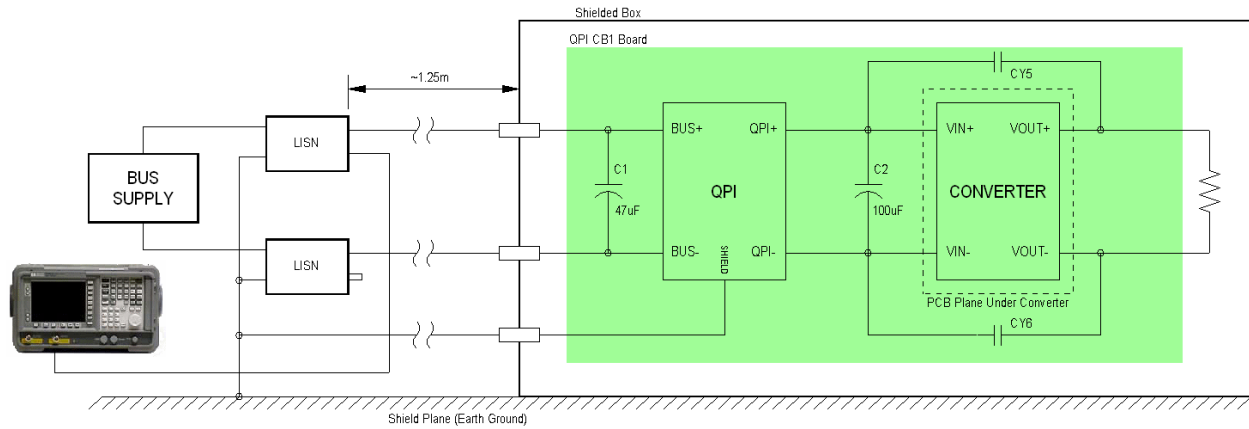

Figure 6 - Open-frame EMI test setup using the QPI-6-CB1 carrier board with 48V converter.

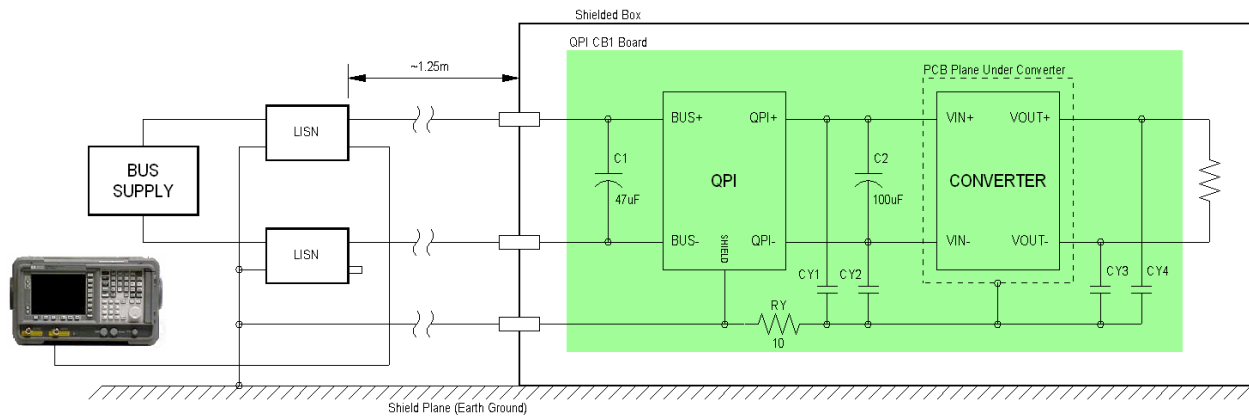

Figure 7 - Base-plate EMI test setup using the QPI-6-CB1 carrier board with 48V converter.

In Figures 6 and 7, C1 is the required 47uF capacitor (United Chemi-Con EMVE101ARA470MKE0S or equivalent), C2 is a converter input cap (value dependant on converter), and CY

caps are 4.7nF ceramic (Murata GRM31BR73A472KW01L or equivalent).

Attenuation Plots: Converters in base-plate and open-frame configurations, tested as shown in Figure 7.

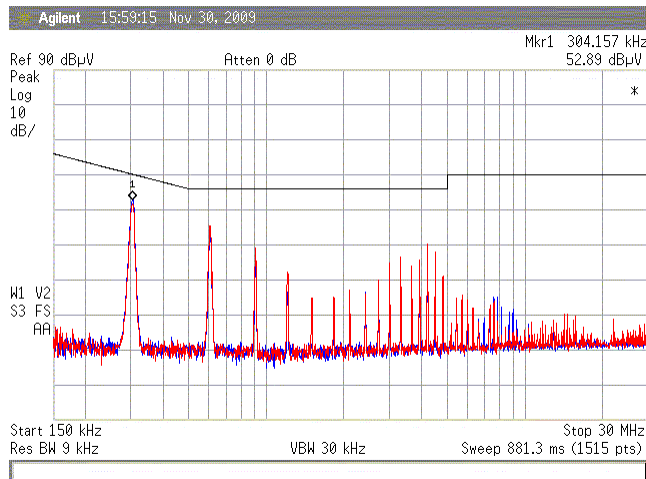

Figure 8 - V48B12C250BN using base-plate "Y" capacitors with a 162W load.

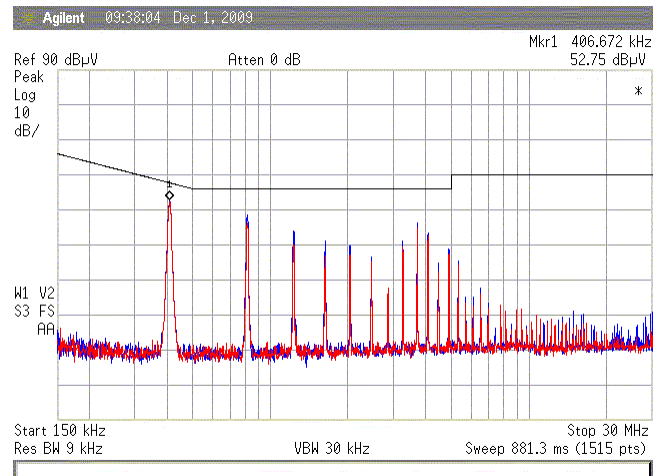

Figure 9 - V48B3V3C150BN using base-plate "Y" capacitors with a 141W load.

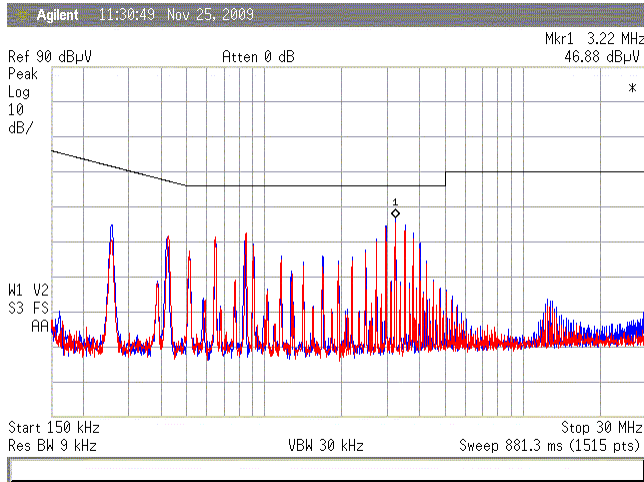

Figure 10 – Ericsson PKM 4402NG using open-frame “Y” capacitors on QPI-6-CB1 evaluation board, 414W load.

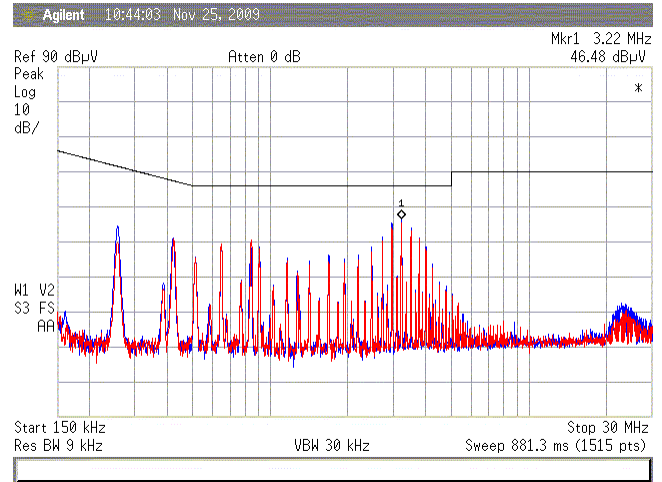

Figure 11 - Ericsson PKM 4402NG using base-plate “Y” capacitors on QPI-6-CB1 evaluation board, 414W load

Current De-Rating: mounted to QPI-6-EVAL1 evaluation board.

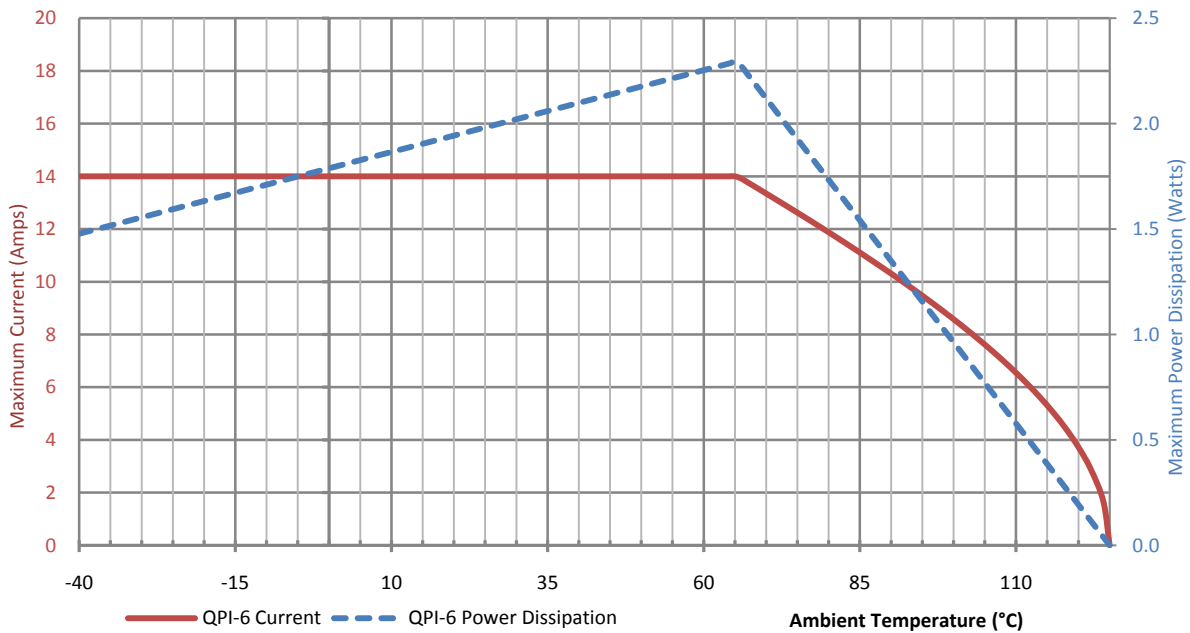

Figure 12 - Current de-rating and power dissipation over ambient temperature range.

The de-rating curve in Figure 12 is based on the maximum allowable internal component temperature and the 14A maximum rating of the QPI-6. The power dissipation curve is based on the current squared multiplied by the internal

resistance between the inputs and outputs of the filter. The internal resistance value is temperature compensated for the power dissipation curve. The left axis is in amps for the solid trace, the right axis is in watts for the dashed trace.

QPI Application Circuits: Filtering Dual Converters

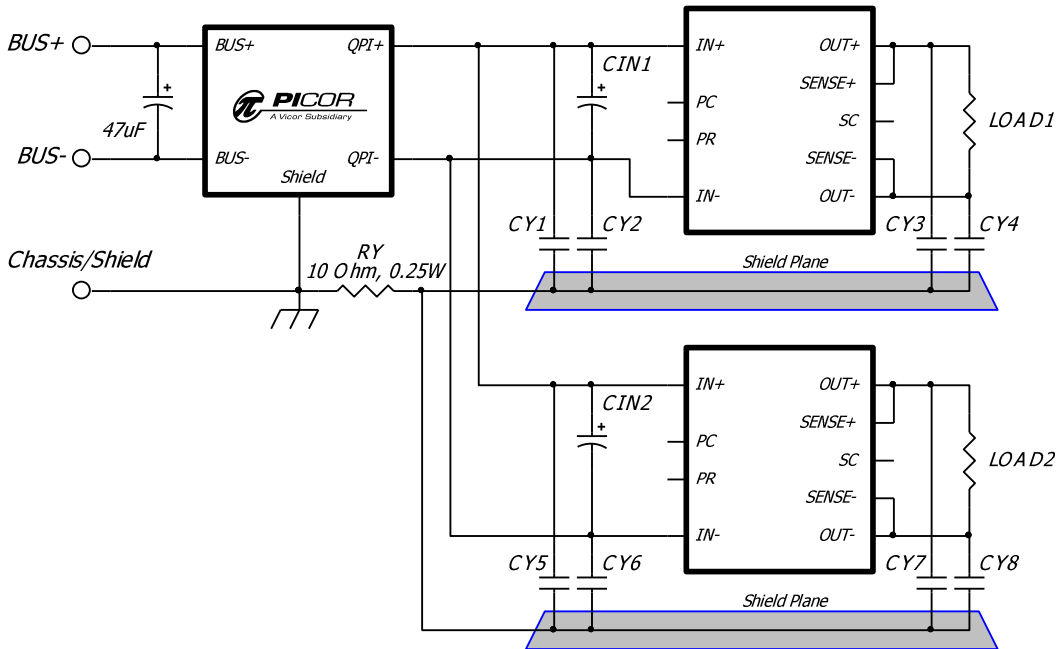

Figure 13 – The QPI-6 filtering dual supplies, using a single RY resistor. ⁽⁴⁾

The shield plane under the two converters in Figure 13 should be one contiguous plane under both. The circuit in Figure 13 is capable of filtering more converters than shown, up to the maximum current limit of the QPI-6. In Figure 14, a separate shield plane is required for each converter along with a

separate RY resistor.

The QPI-6 is not designed to be used in parallel with another QPI-6 to achieve a higher current rating, but it can be used multiple times within a system design.

Filtering Parallel Converters

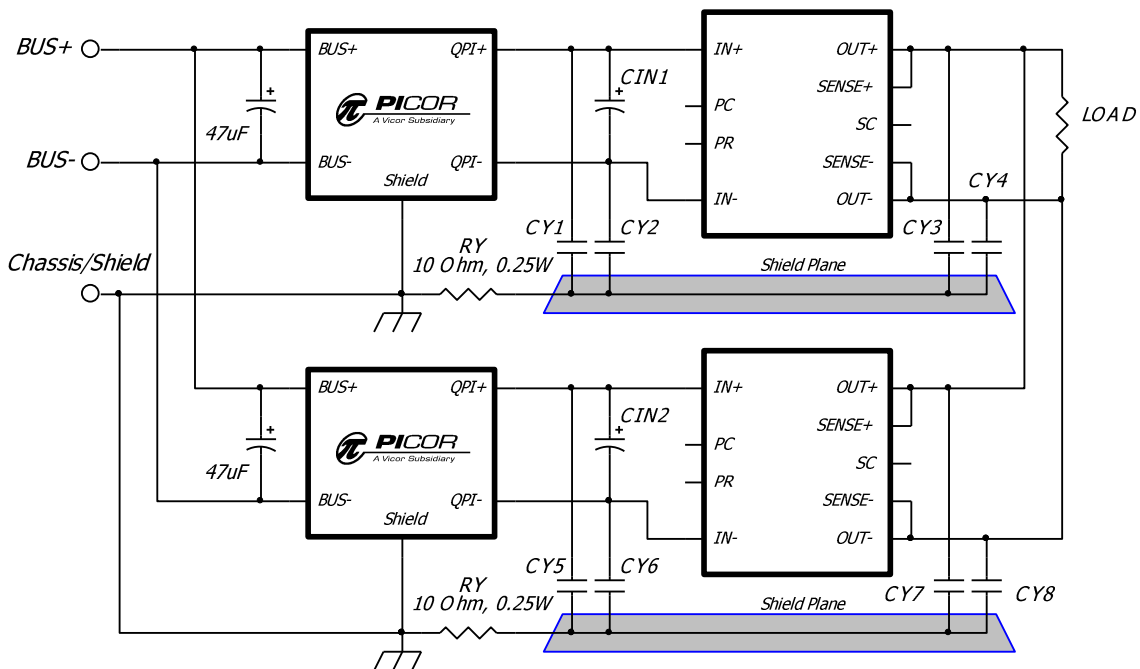

Figure 14 – Dual QPI-6's filtering paralleled converters feeding a common load. ⁽⁴⁾

Note 4: In Figures 12 and 13; CIN1 and CIN2, CY1 through CY8, should be the value and voltage rating recommended by the converter's manufacturer.

Output to Chassis Connection Using the QPI-6

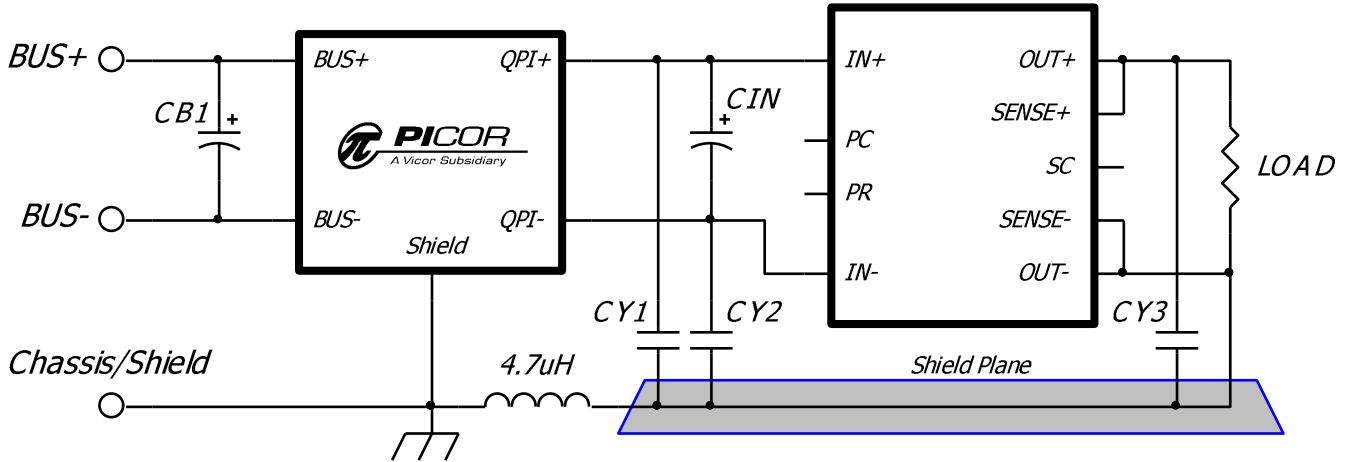

Figure 15 – Connecting the converter’s output ground to chassis through an inductor. ⁽⁴⁾

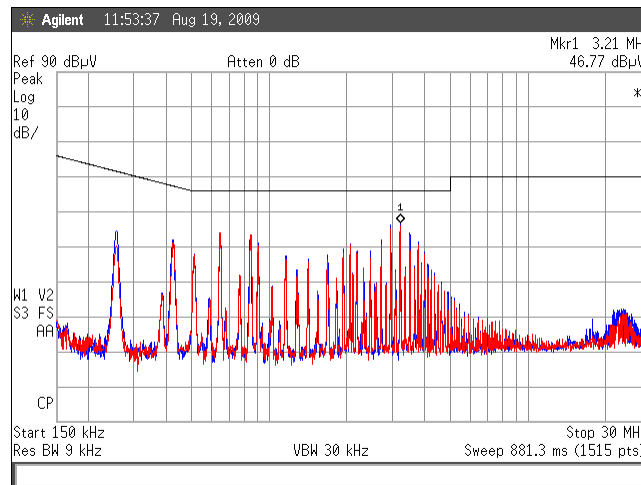

Figure 16 -Total Noise EMI Plots of PKM 4402NG, connected as shown in Figure 15

The direct connection of the converter’s output to the earth/chassis will degrade the EMI attenuation performance of the QPI-6. Picor recommends that the connection to the earth be made through a series inductor, rated to the maximum output current of the converter, as shown in Figure 15. The EMI plot shown in Figure 16 is of the same converter as in

Figure 11, but uses an inductor in place of RY and has the converter’s output ground connected to the shield plane.

The connection of the shield plane directly to the chassis/earth will also degrade EMI attenuation by the QPI-6 and is therefore not recommended.

QPI Insertion Loss Measurements

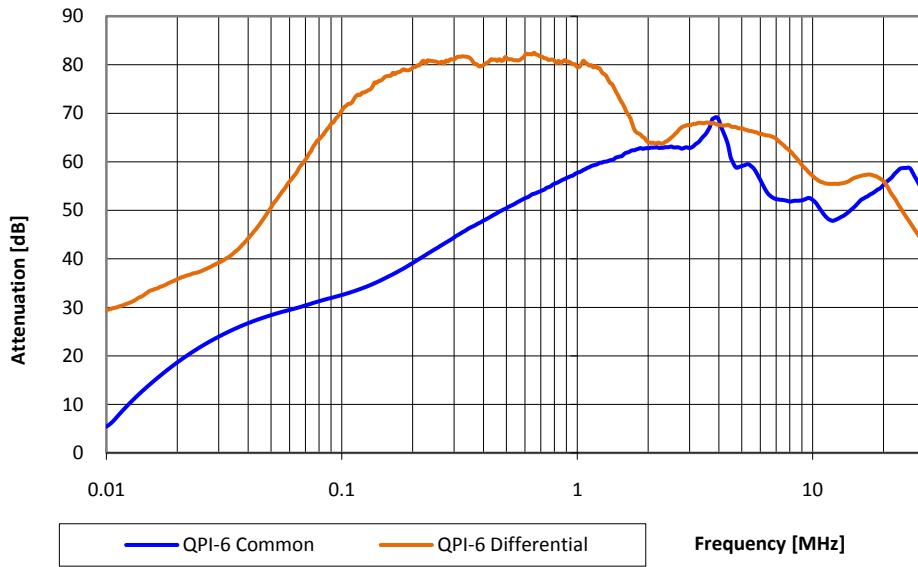

QPI Insertion Loss Equation:

$$\text{Insertion Loss} = 20 * \log * \left[\frac{I_{INA}}{I_{INB}} \right]$$

Figure 17 - Attenuation curves into a 50Ω line impedance, bias from a 48V bus.

QPI Insertion Loss Test Circuits

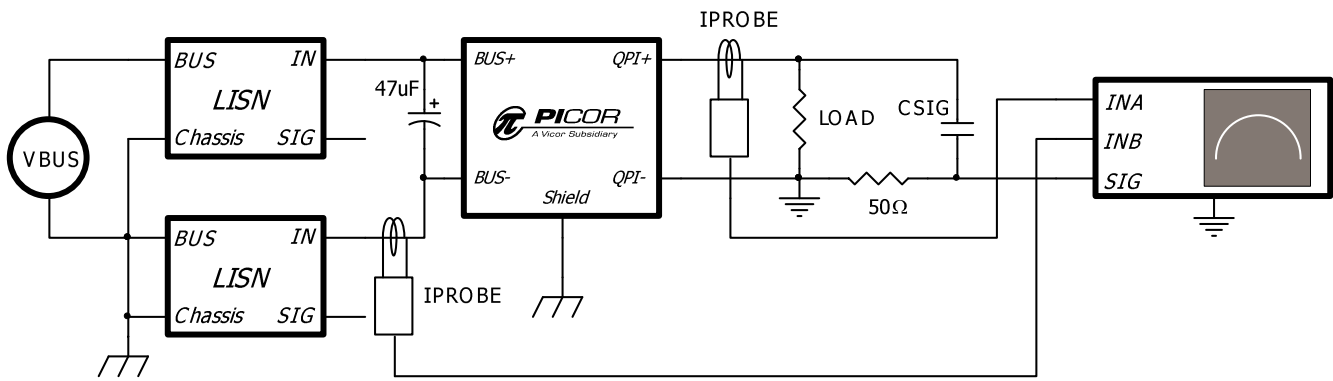

Figure 18 – Test Set-up to measure Differential Mode EMI currents in Figure 17.

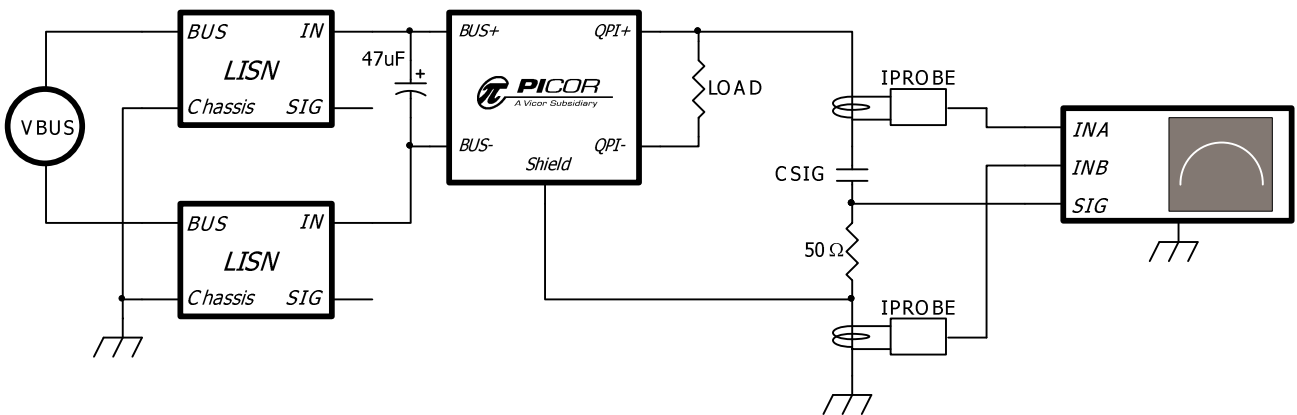

Figure 19 - Test Set-up to measure Common Mode EMI currents in Figure 17.

Mechanicals

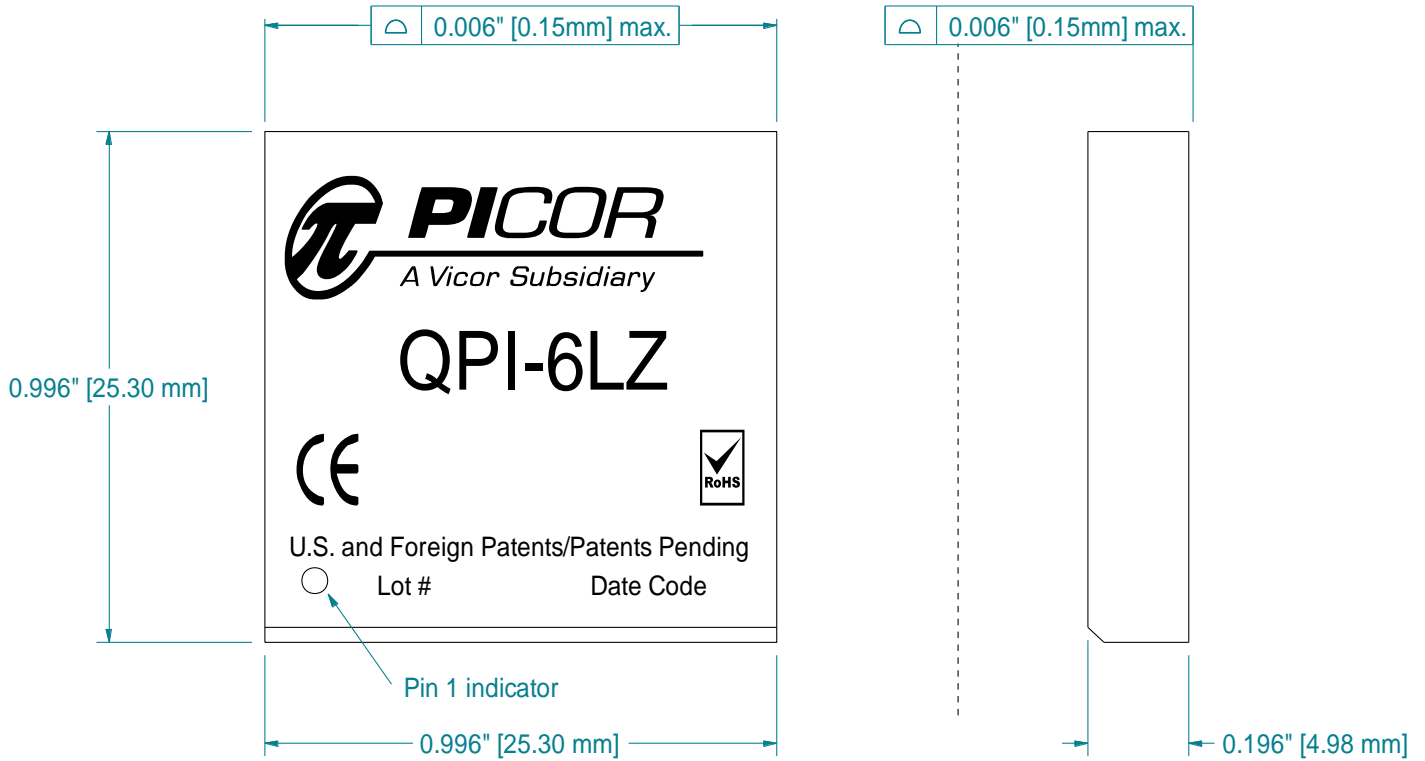

Figure 20 - Lidded Package Dimensions, tolerance of ± 0.004 "

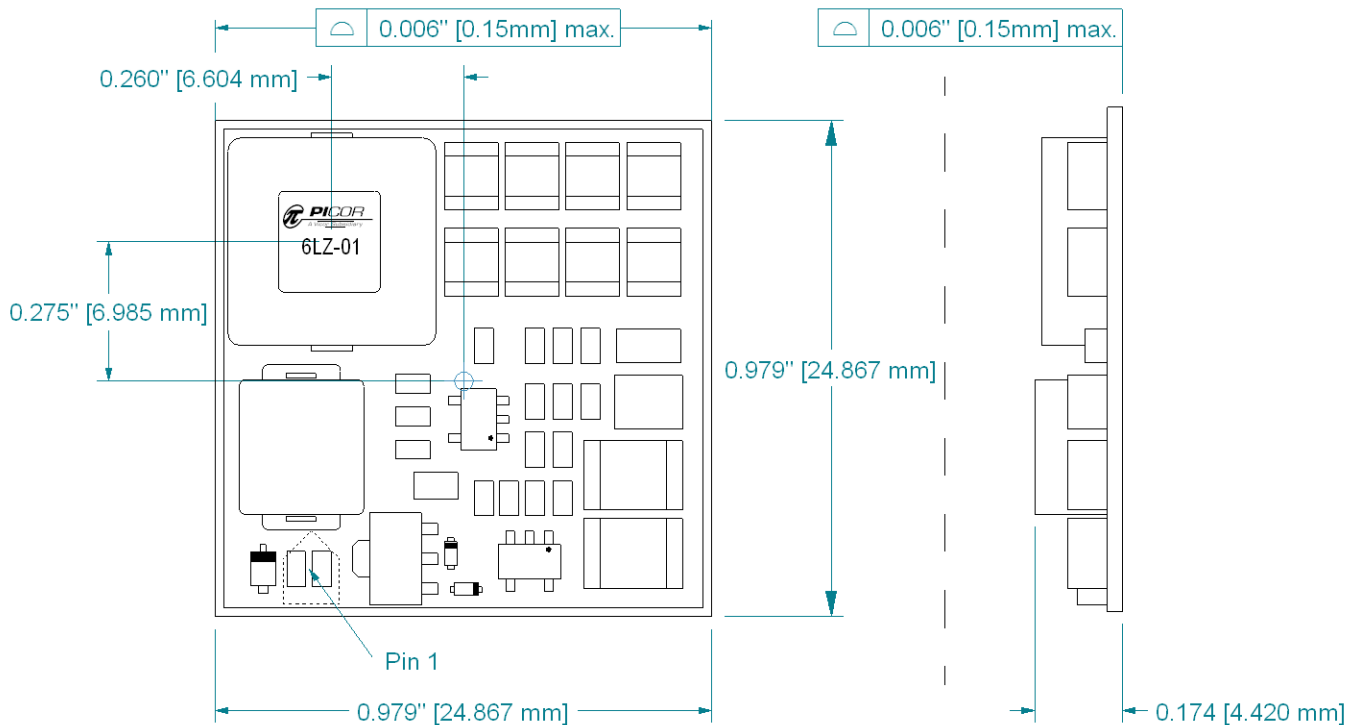
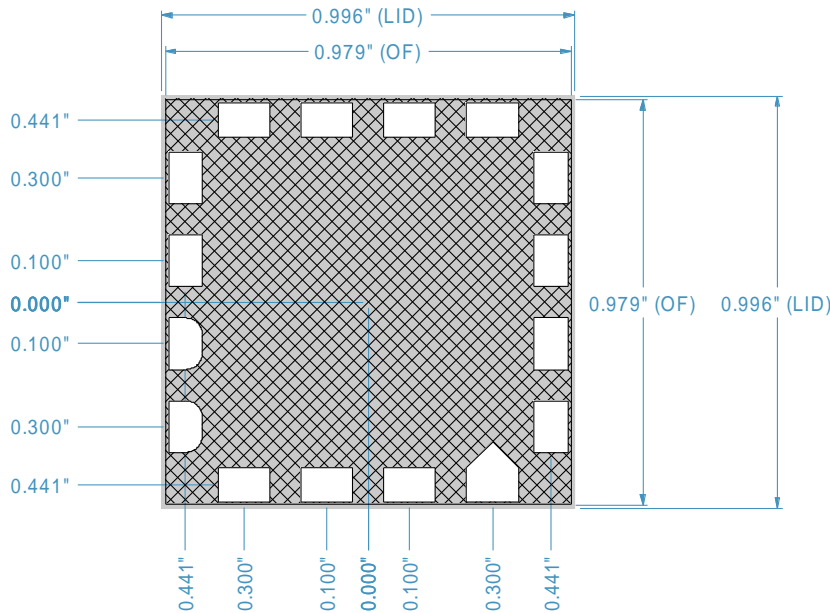

Figure 21 - Open-frame Package dimensions, tolerance of ± 0.004 ". Pick and Place from label center.

Pad and Stencil Definitions:

**QPI-6 LGA
Pattern
(Bottom View)**



**QPI-6 PCB
Receptor Pattern
(Top View)**

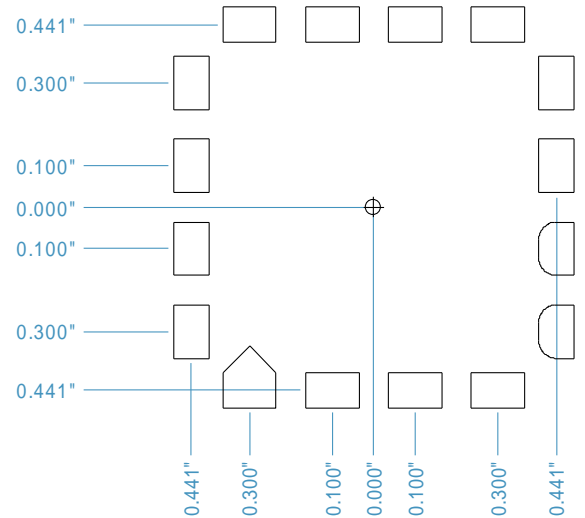

Figure 22 - Bottom view of open-frame (OF) and lidded (LID) products. (All dimensions are in inches.)

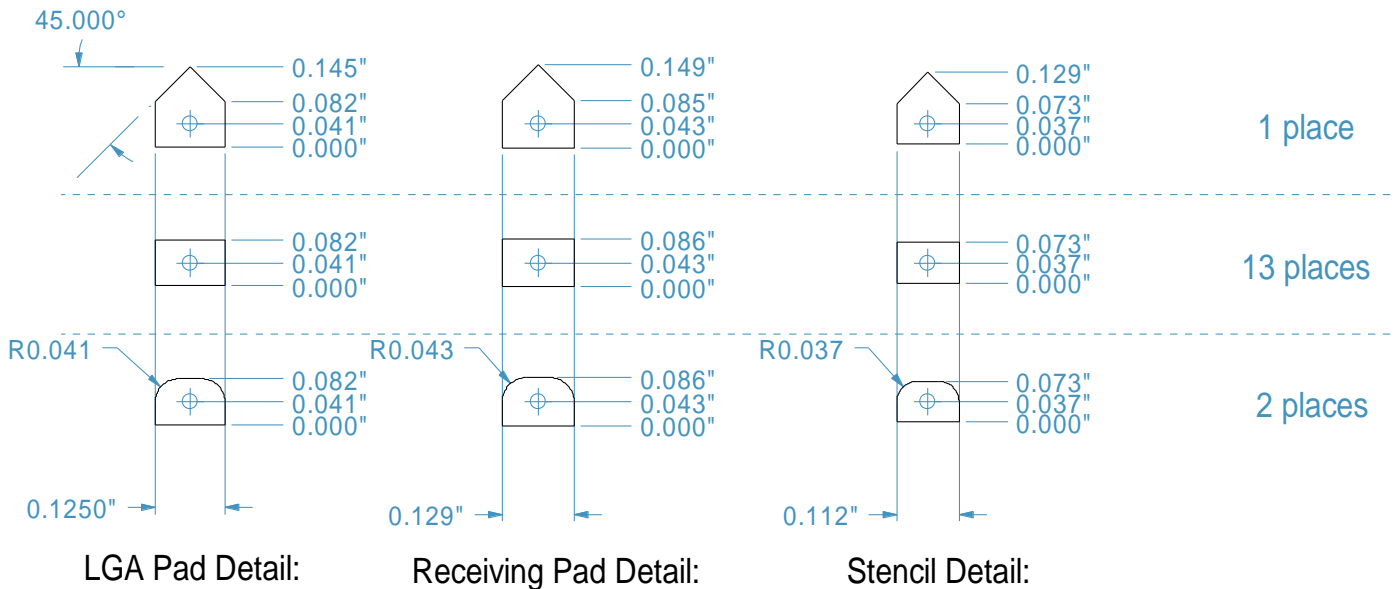

Figure 23 - Recommended receptor and stencil patterns. (All dimensions are in inches.)

Stencil definition is based on a 6mil stencil thickness, 80% of LGA pad area coverage. LGA Package dimensions are for both the Open-Frame and Lidded versions of the QPI-6.

QPI-6 PCB Layout Recommendations:

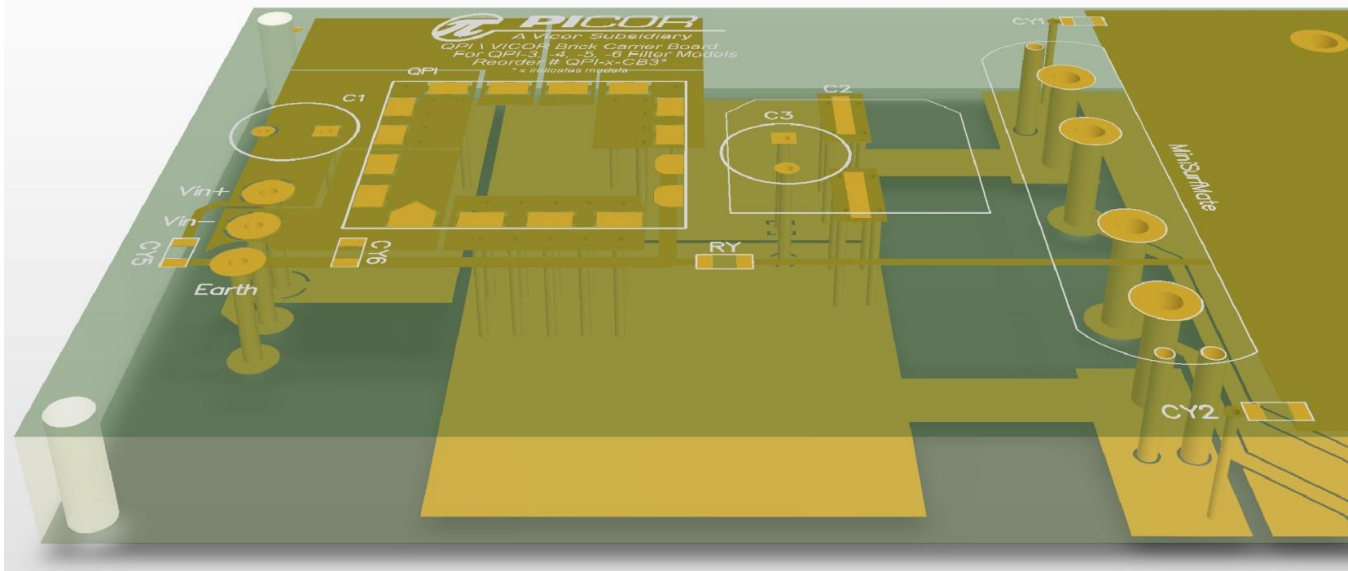

Figure 24 - 3D view of paralleling planes underneath the QPI-6.

PCB Layout

When laying out the QPI-6 EMI filter it is important for the designer to be aware of the radiated EMI field that all converters emit and to place the QPI-6 outside of this field area. It is also recommended that the bus lines feeding into the QPI filter are not routed such that they lie between the QPI and the converter, or that their copper planes over-lap on inner layers. This can cause EMI noise to be coupled from input to output via the parasitic capacitance between the planes.

In Figure 24, the QPI-6 is located ~1.5 inches from the converter’s input pins, and the BUS voltage pins are located on the side farthest away from the converter, to keep the radiated EMI from by-passing the filter and coupling directly to the BUS feeds.

Post Solder Cleaning

Picor’s LZ version QP SIPs are not hermetically sealed and must not be exposed to liquid, including but not limited to cleaning solvents, aqueous washing solutions or pressurized sprays. When soldering, it is recommended that no-clean flux solder be used, as this will ensure that potentially corrosive mobile ions will not remain on, around, or under the module following the soldering process. For applications where the end product must be cleaned in a liquid solvent, Picor recommends using the QPI-6LZ-01, open-frame version of the EMI filter.

QPI-6 Mechanical Data

Datum	Units	QPI-6LZ	QPI-6LZ-01	Notes
FITS	Failure/Billion Hrs.	208	208	FITS based on the BellCore Standard TR-332
MTBF	Million Hrs.	4.81	4.81	MTBFs based on the BellCore Standard TR-332
Weight	grams	5.4	3.1	
MSL		3	3	
Peak reflow Temperature	°C/20 seconds	245	245	IPC/JEDEC J-STD-020D

Warranty

Vicor products are guaranteed for two years from date of shipment against defects in material or workmanship when in normal use and service. This warranty does not extend to products subjected to misuse, accident, or improper application or maintenance. Vicor shall not be liable for collateral or consequential damage. This warranty is extended to the original purchaser only.

EXCEPT FOR THE FOREGOING EXPRESS WARRANTY, VICOR MAKES NO WARRANTY, EXPRESS OR LIMITED, INCLUDING, BUT NOT LIMITED TO, THE WARRANTY OF MERCHANTABILITY OR FITNESS FOR A PARTICULAR PURPOSE.

Vicor will repair or replace defective products in accordance with its own best judgment. For service under this warranty, the buyer must contact Vicor to obtain a Return Material Authorization (RMA) number and shipping instructions. Products returned without prior authorization will be returned to the buyer. The buyer will pay all charges incurred in returning the product to the factory. Vicor will pay all reshipment charges if the product was defective within the terms of this warranty.

Information published by Vicor has been carefully checked and is believed to be accurate; however, no responsibility is assumed for inaccuracies. Vicor reserves the right to make changes to any products without further notice to improve reliability, function, or design. Vicor does not assume any liability arising out of the application or use of any product or circuit; neither does it convey any license under its patent rights nor the rights of others. Vicor general policy does not recommend the use of its components in life support applications wherein a failure or malfunction may directly threaten life or injury. Per Vicor Terms and Conditions of Sale, the user of Vicor components in life support applications assumes all risks of such use and indemnifies Vicor against all damages.

Vicor's comprehensive line of power solutions includes high density AC-DC and DC-DC modules and accessory components, fully configurable AC-DC and DC-DC power supplies, and complete custom power systems.

Information furnished by Vicor is believed to be accurate and reliable. However, no responsibility is assumed by Vicor for its use. Vicor components are not designed to be used in applications, such as life support systems, wherein a failure or malfunction could result in injury or death. All sales are subject to Vicor's Terms and Conditions of Sale, which are available upon request.

Specifications are subject to change without notice.

Vicor Corporation
25 Frontage Road
Andover, MA 01810
USA

Picor Corporation
51 Industrial Drive
North Smithfield, RI 02896
USA

Customer Service: custserv@vicorpower.com
Technical Support: apps@vicorpower.com
Tel: 800-735-6200
Fax: 978-475-6715