

Surface Mount PTC

0ZTF Series

HF  0ZTF Series – 2920 Chip

RoHS Compliant

Product Features

- Small surface mountable, Solid state, Faster time to trip than standard SMD devices, Lower resistance than standard SMD devices
- Full compliance with EU Directive 2011/65/EU and amending directive 2015/863
- AEC-Q Compliant
- Meets Bel automotive qualification*
 - * - Largely based on internal AEC-Q test plan

Operating (Hold Current) Range

1.10A

Maximum Voltage

16V

Temperature Range

-40°C to 125°C

Agency Approval

TUV (Std. EN/IEC 60738-1-1 and EN/IEC 60730-1, Cert. R50102117)

UL Recognized Component (Std. UL1434, File E305051)





AEC-Q Compliant

LEAD FREE = 

HALOGEN FREE = 

Electrical Characteristics (23°C)

| | Part Number | Hold Current | Trip Current | Rated Voltage | Maximum Current | Typical Power | Max Time to Trip | | Resistance Tolerance | | Agency Approvals | |
|---|--------------|--------------------|--------------------|------------------------------------|----------------------|--------------------|------------------|------|----------------------|-------------------|---|---|
| | | I _H , A | I _T , A | V _{max} , V _{dc} | I _{max} , A | P _d , W | Current | Time | R _{min} | R _{1max} |  |  |
| | | | | | | | A | Sec | Ohms | Ohms | | |
| A | 0ZTF0110FF2C | 1.10 | 2.20 | 16 | 50 | 2.0 | 8.00 | 2.00 | 0.090 | 0.410 | Y | Y |

I_H=Hold current-maximum current at which the device will not trip at 23°C still air.

I_T=Trip current-minimum current at which the device will always trip at 23°C still air.

V_{MAX}=Maximum voltage device can withstand without damage at it rated current.(I_{MAX})

I_{MAX}= Maximum fault current device can withstand without damage at rated voltage (V_{MAX}).

P_d=Typical power dissipated-type amount of power dissipated by the device when in the tripped state in 23°C still air environment.

R_{MIN}=Minimum device resistance at 23°C prior to tripping.

R_{1MAX}=Maximum device resistance at 23°C measured 1 hour after tripping or reflow soldering of 260°C for 20 seconds.

PTC's – Basic Theory of Operation / “Tripped” Resistance Explanation

A Bel PTC consists of a block of polymeric material containing conductive carbon granules which is sandwiched between two conductive metal plates. When this polymer block reaches approximately 165C, either due to current passing through it via conductive chains of carbon particles or due to an external heat source; it swells volumetrically. This expansion breaks apart a majority of the chains of carbon granules that run randomly between the two conductive plates. This behavior results in a sharp increase in resistance across the two plates which all but eliminates current flow through the device, allowing just enough residual current flow to maintain the block’s internal temperature at 165C. Once this “tripped” state current is cut off, the polymer brick cools and shrinks to its original size, thereby allowing its broken carbon chains to reestablish themselves and permit the part to return to its low resistance state. Once cooled to room ambient, the PTC will once again exhibit a resistance less than its “R1max” rating.

At currents below the device I_{HOLD} rating, AND at temperatures below 125C, the PTC maintains a resistance value below its R1 MAX rating.

The catalog data for each device specifies a "Typical Power" value. This is the power required to exactly match the heat lost by the tripped device to its ambient surroundings at 23C. By Ohm's Law, power can be stated as: $W = E^2/R$. Thus the approximate resistance of a “Tripped” PTC can be determined by: $R = E^2/W$, where "E" is the voltage appearing across the PTC (usually the supply's open circuit voltage), and "W" is the Typical Power value for the particular PTC.

Since the PTC acts to maintain a constant internal temperature, its apparent resistance will change based upon applied voltage and, to a lesser degree, ambient conditions. Consider the following example....

A PTC with a Typical Power of 1 watt protecting a circuit using a 60V supply will demonstrate an apparent, tripped resistance "R" of:

$$R = 60^2/1 = 3,600 \text{ ohms}$$

This same tripped device when used to protect a 12V circuit would now present an apparent resistance of:

$$R = 12^2/1 = 144 \text{ ohms}$$

The value for Typical Power is "typical" because any physical factors that affect heat loss (such as ambient temperature or air convection) will somewhat alter the level of power that the PTC needs to maintain its internal temperature. In short, PTCs do not exhibit a constant, quantifiable tripped resistance value.

Average Time Current Characteristic Curve at 23°C

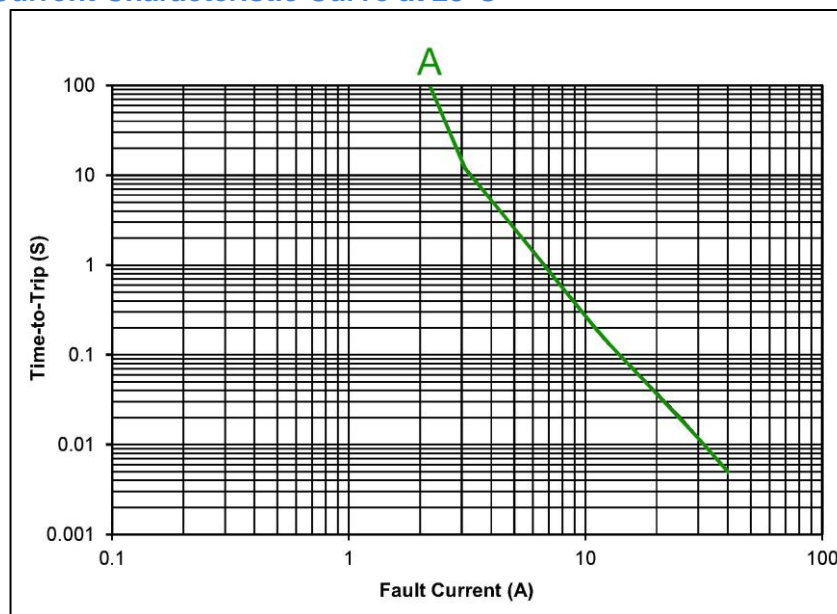

The Average Time Current Characteristic Curve and Temperature Derating Curve are affected by a number of variables and these curves are provided for guidance only.



Specifications subject to change without notice

Bel Fuse Inc.
206 Van Vorst Street
Jersey City, NJ 07302 USA

+1 201.432.0463
Bel.US.CS@belf.com
belfuse.com/circuit-protection

Pad Layout

The dimensions in the table below provide the Recommended pad layout.

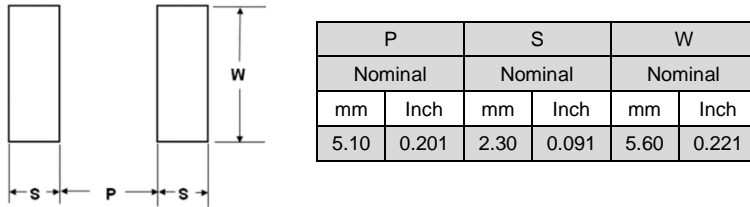

Termination Pad Materials

Pure Tin

Mechanical Dimensions and Marking

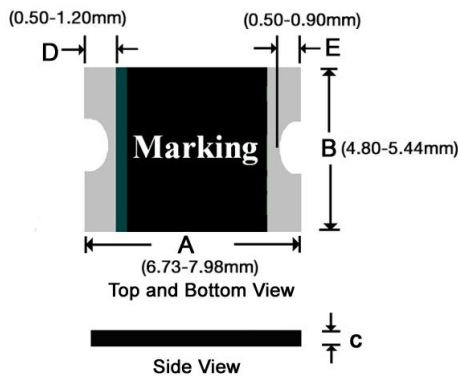

All dimensions in mm.

| Part Number | Dimensions | | Marking Code | |
|--------------|------------|------|--------------------------|------|
| | C | | "b", I _H code | |
| | Min | Max | bT | XXXX |
| 0ZTF0110FF2C | 0..30 | 1.70 | bT | 0110 |

Temperature Derating Table

| Temperature Derating Table | | | | | | | | | | | |
|----------------------------|------|------|------|------|-----|-----|-----|-----|-----|-----|-----|
| I Hold Value | -40 | -20 | 0 | 23 | 30 | 40 | 50 | 60 | 70 | 85 | 125 |
| 0ZTF0110 | 136% | 125% | 112% | 100% | 96% | 89% | 83% | 78% | 73% | 56% | 40% |

Thermal Derating Curve

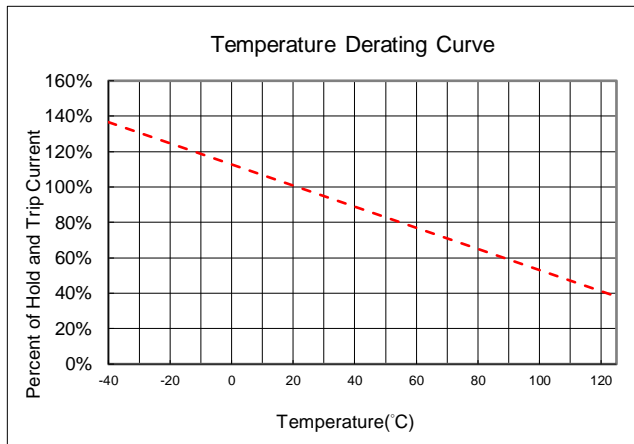

Cautionary Notes

1. Operation beyond the specified maximum ratings or improper use may result in damage and possible electrical arcing and/or flame.
2. These Polymer PTC (PPTC) devices are intended for protection against occasional overcurrent/overtemperature fault conditions and may not be suitable for use in applications where repeated and/or prolonged fault conditions are anticipated.
3. Avoid contact of PTC device with chemical solvent. Prolonged contact may adversely impact the PTC performance.
4. These PTC devices may not be suitable for use in circuits with a large inductance, as the PTC trip can generate circuit voltage spikes above the PTC rated voltage.
5. These devices may be used in both DC and AC circuits provided that peak-to-peak line voltage when carrying AC does not exceed the PTC's V_{max} rating. As PTCs are essentially thermal devices, the RMS value of AC current carried by a PTC will produce tripping parameters and times-to-trip similar to those of a DC voltage of the same magnitude.
6. If potting is mandated, avoid rigid potting compounds as they will encase the PTC and prevent it from volumetrically expanding to properly respond to a trip event.
7. MSL: 2a (According to IPC J-Std-020).



Specifications subject to change without notice

Bel Fuse Inc.
206 Van Vorst Street
Jersey City, NJ 07302 USA

+1 201.432.0463
Bel.US.CS@belf.com
belfuse.com/circuit-protection

Environmental Specifications

| | |
|------------------------------|------------------------|
| Temperature cycling | JESD22 Method JA-104 |
| Biased humidity | MIL-STD-202 Method 103 |
| Operational life | MIL-STD-202 Method 108 |
| Resistance to solvents | MIL-STD-202 Method 215 |
| Mechanical shock | MIL-STD-202 Method 213 |
| Vibration | MIL-STD-202 Method 204 |
| Resistance to soldering heat | MIL-STD-202 Method 210 |
| Thermal shock | MIL-STD-202 Method 107 |
| Solderability | ANSI/J-STD-002 |
| Board flex(SMD) | AEC-Q200-005 |
| Terminal strength | AEC-Q200-006 |

Solder Reflow and Rework Recommendations

| Profile Feature | Pb-Free Assembly |
|---|------------------|
| Average Ramp-Up Rate (T _{smax} to T _p) | 3°C/second max |
| Preheat : | |
| Temperature Min (T _{smin}) | 150°C |
| Temperature Max (T _{smax}) | 200°C |
| Time (t _{smin} to t _{smax}) | 60-180 seconds |
| Time maintained above: | |
| Temperature(T _L) | 217°C |
| Time (t _L) | 60-150 seconds |
| Peak/Classification Temperature(T _p) : | 260°C |
| Time within 5°C of actual Peak : | |
| Temperature (t _p) | 20-40 seconds |
| Ramp-Down Rate : | 6°C/second max. |
| Time 25°C to Peak Temperature : | 8 minutes max |

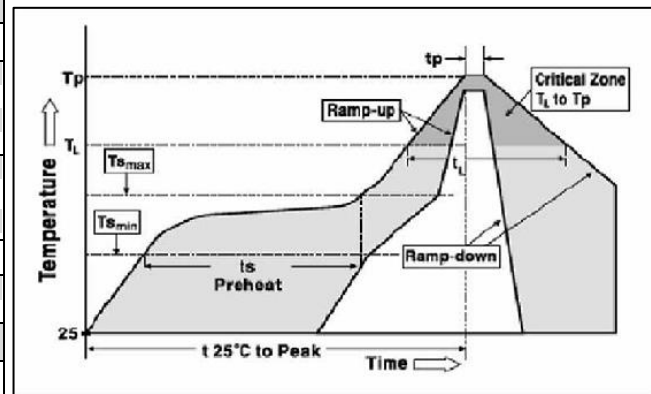

Solder Reflow

Due to "lead free / RoHS Compliant" construction of these PTC devices , the required Temperature and Dwell Time in the " Soldering " zone of the reflow profile are greater than those used for non-RoHS devices.

1. Recommended reflow methods; IR, vapor phase oven, hot air oven.
2. Not Recommended For Wave Solder / Direct Immersion.
3. Recommended paste thickness range – 0.20 – 0.25mm.
4. Devices are compatible with standard industry cleaning solvents and methods.
5. MSL: 2a (According to IPC J-Std-020).

Caution

If reflow temperature / dwell times exceed the recommended profile, the electrical performance of the PTC may be affected.

Rework: MIL-STD-202G Method 210F, Test Condition A.

Standard Packaging

| Part Number | Tape/Reel Qty |
|--------------|---------------|
| 0ZTF0110FF2C | 2,000 |

2000 fuses in 7 inches dia. Reel, 8mm wide tape, 4mm pitch, per EIA-481 (equivalent IEC-286 part 3).

P/N Explanation and Ordering Information

| | | | | | |
|--|-------------|-------------|----------|----------|-----------|
| | 0ZTF | XXXX | X | X | XX |
| PTC series | _____ | _____ | _____ | _____ | _____ |
| 0ZTF, 2920 Size | | | | | |
| I HOLD Rating | _____ | _____ | _____ | _____ | _____ |
| Refer to Part Number and IH Rating in Electrical Characteristics Table on P.1. | | | | | |
| Electrical Characteristics | _____ | _____ | _____ | _____ | _____ |
| F = Standard Design | | | | | |
| A to Z (except F) = Special, customer spec, DCR sort, etc. | | | | | |
| Mechanical Features | _____ | _____ | _____ | _____ | _____ |
| F = Standard Design | | | | | |
| A to Z (except F) = Special, customer spec, lead forming, etc. | | | | | |
| Tape & Reel Qty | _____ | _____ | _____ | _____ | _____ |
| See standard packaging | | | | | |



Specifications subject to change without notice

Bel Fuse Inc.
206 Van Vorst Street
Jersey City, NJ 07302 USA

+1 201.432.0463
Bel.US.CS@belf.com
belfuse.com/circuit-protection