

# LDP200-200

200 W DIN Rail

## Programmable Power Supply

LDP200-200 is the first user programmable unit on the market that can supply any voltage between 36 and 205 VDC, offering unmatched flexibility for many applications.

Its compact size, high efficiency, excellent reliability together with easy installation makes it ideal for various industrial applications.

LDP200-200 is Class I isolation device designed to be mounted on DIN rail and installed inside a protective enclosure.



### FEATURES

- Wide AC input voltage range 170 - 550 VAC or wide DC input voltage range 250 - 725 VDC
- Wide output voltage range 36 - 205 VDC (user settable)
- 2 user programmable voltage steps with settable duration
- Digital Power regulation
- Remote ON/OFF or other remote control functions through ENABLE input
- Operating temperature up to +50°C with no derating
- High efficiency 87 %
- Active PFC
- Multiple protections
- Compact size 80 x 120 x 100 mm



### APPLICATIONS

- Industrial control
- Instrumentation equipment
- Elevator applications
- Renewable energy systems

## 1. MODEL SELECTION

MODEL	INPUT VOLTAGE RANGE	# OF PHASES	OUTPUT VOLTAGE	MAX OUTPUT CURRENT <sup>1</sup>	EFFICIENCY	MAX OUTPUT POWER
LDP200-200	200 - 500 VAC (250 - 725 VDC)	1 / 2	36 - 205 VDC	2.3 A	87 %	200 W

<sup>1</sup> Max. 2.3 A or  $V_{out} \times I_{out} = 187 \text{ W Max. for } V_{out} > 80 \text{ VDC}$

## 2. INPUT SPECIFICATIONS

PARAMETER	DESCRIPTION / CONDITIONS	SPECIFICATION
AC Input Voltage <sup>2</sup>	Nominal 1 / 2 phases Range	200 - 500 VAC 170 - 550 VAC
DC Input Voltage	Range	250 - 725 VDC
Input Frequency		47 - 63 Hz
AC Input Current	$V_{in} = 200 \text{ VAC}$	1.4 A
	$V_{in} = 500 \text{ VAC}$	0.5 A
DC Input Current	$V_{in} = 250 \text{ VDC}$	1.4 A
	$V_{in} = 725 \text{ VDC}$	0.7 A
Inrush Peak Current $I_{\text{t}}^{\text{t}}$	Peak Current measured after 0.2 ms from main connection; 400 VAC / 50 Hz; $T_a = 25^\circ\text{C}$ ; Cold Start	$\leq 40 \text{ A}$ 0.69 $\text{A}^2\text{s}$
Standby Power		$< 6 \text{ W}$
Power Factor Correction	Active	$> 0.9$
Touch (Leakage) Current		$\leq 0.3 \text{ mA}$
Internal Protection Fuse	None, external fuse must be provided	
Recommended External Protection	It is strongly recommended to provide external surge arresters (SPD) according to local regulations.	MCB 6 A C curve or MCB 4 A D curve

<sup>2</sup> CB Scheme certified up to 528 VAC.

## 3. OUTPUT SPECIFICATIONS

PARAMETER	DESCRIPTION / CONDITIONS	SPECIFICATION
Output Voltage (Adjustable)	1 V resolution programmable	36 - 205 VDC
Output Current (Continuous)	or $V_{out} \times I_{out} = 187 \text{ W Max. for } V_{out} > 80 \text{ VDC}$	2.3 A max
Load Regulation		$\leq 1.0 \%$
Ripple & Noise <sup>3</sup>		$\leq 600 \text{ mVpp}$
Hold-up Time		$\geq 30 \text{ ms}$
Status Signals	7 segment, 3 digits display 3 programming keys ENABLE - Insulated remote ON/OFF input, active for 12 - 230 VAC/DC	
Parallel Connection	Possible with external ORing module	

<sup>3</sup> Ripple and Noise are measured with 20 MHz bandwidth, probe terminated with a 0.1  $\mu\text{F}$  MKP parallel capacitor.

## 4. PROTECTIONS

PARAMETER	DESCRIPTION / CONDITIONS	SPECIFICATION
Short Circuit Protection	Short Circuit Peak Current (constant current (3 s) and one shot (no auto recovery))	2.5 A
Overload Protection	Overload Limit (constant current (3 s) & one shot (no auto recovery))	2.4 A
Thermal Protection		
Input Undervoltage Lockout (UVLO)		
Input Overvoltage Protection (VDR)		

## 5. ENVIRONMENTAL, EMC & SAFETY SPECIFICATIONS

PARAMETER	DESCRIPTION / CONDITIONS	SPECIFICATION
Operating Temperature	Start-up type tested: - 40°C, possible at Vnom with load deration.	-40 to +70 °C
Storage Temperature		-40 to +80 °C
Derating	Over 50°C (do not exceed $V_{out} \times I_{out} = 100 \text{ W Max. at } 70^\circ\text{C}$ )	- 4.2 W/°C
Dissipated Power		< 28 W
Humidity	Non-condescending	5 - 95 % RH
Life Time Expectancy	Ta = 25°C, full load	71 686 (8.1) hrs (years)
MTBF	MIL-HDBK-217F at Ta = 25°C, full load	> 500 000 hrs
Overvoltage Category	EN 50178	III
Pollution Degree	IEC 60664-1	2
Isolation	Input to Output Input to Ground Output to Ground	4.2 kVDC 2.2 kVDC 0.75 kVDC
Safety Standards & Approvals	UL 508 (certified) IEC/EN 61010-1 IEC/EN 61010-2-201 IEC/EN 60950	
EMC Emissions	EN 55011 / CISPR 11 EN 55022 / CISPR 22 EN 12015 EN 61000-3-2	Class A Class A Class A Class A
EMC Immunity	EN 61000-4-2 EN 61000-4-3 EN 61000-4-4 EN 61000-4-5 EN 61000-4-11 EN 12016	Level 3 Level 3 Level 3 Level 4 Level 2
Protection Degree	EN 60529	IP20
Vibration Sinusoidal	IEC 60068-2-6	5 - 17.8 Hz: ±1.6 mm; 17.8 - 500 Hz: 2 g 2 hours / axis (X,Y, Z)
Shock	IEC 60068-2-27	30 g 6 ms, 20 g 11 ms; 3 bumps / direction, 18 bumps total

## 6. MECHANICAL SPECIFICATIONS

PARAMETER	DESCRIPTION / CONDITIONS	SPECIFICATION
Dimensions		80 x 120 x 100 mm 3.15 x 4.72 x 4.94 in
Weight		750 g
Mounting Rail	IEC 60715/H15/TH35-7.5(-15)	
Connection Terminals	Screw type pluggable (24 - 12 AWG)	2.5 mm <sup>2</sup>
Case Material	Aluminum	

## 7. MECHANICAL DRAWING

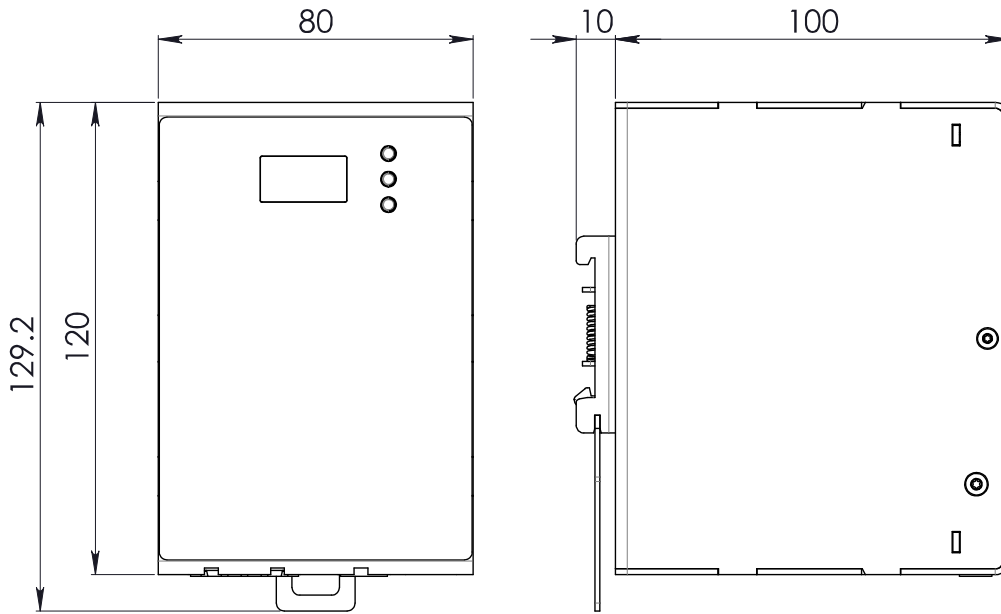
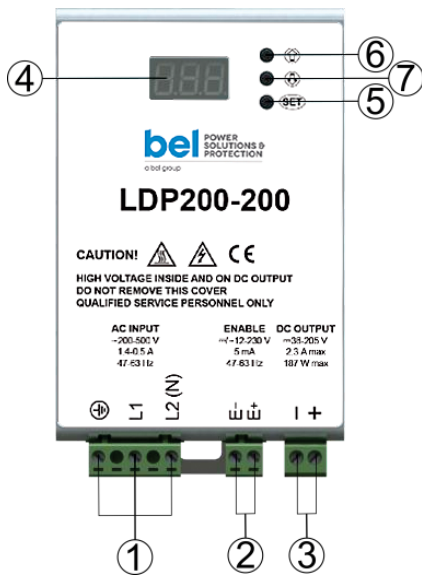

Figure 2. Mechanical Drawing

## 8. PIN LAYOUT & DESCRIPTION



PIN	DESCRIPTION
1	AC/DC input
2	Enable input
4	DC output (load)
5	Display
6	SET button menu
7	UP button menu
8	DOWN button menu

INPUT CONNECTION	Single-phase	Two-phase
	L = Line N = Neutral ⊕ = Earth ground	L1 = Phase 1 L2 = Phase 2 ⊕ = Earth ground
	DC Input	Enable (12 - 230 VAC/DC)
	L1 = + Positive DC L2 = - Negative DC ⊕ = Earth ground	E+ = Positive DC E- = Negative DC
OUTPUT CONNECTION	+ = Positive DC - = Negative DC	

**Notes:**

Technical parameters are typical, measured in laboratory environment at 25°C and 400 VAC / 50 Hz, at nominal values, after minimum 5 minutes of operation. Power rating, losses, efficiency, ripple, thermal behaviour and start-up may change outside of the nominal rated input range. Contact factory for details.

**NUCLEAR AND MEDICAL APPLICATIONS** - Products are not designed or intended for use as critical components in life support systems, equipment used in hazardous environments, or nuclear control systems.

**TECHNICAL REVISIONS** - The appearance of products, including safety agency certifications pictured on labels, may change depending on the date manufactured. Specifications are subject to change without notice.