

THE INFORMATION CONTAINED HEREIN IS CONSIDERED "PROPRIETARY" TO BEL FUSE INC. AND SHALL NOT BE COPIED, REPRODUCED OR DISCLOSED WITHOUT THE WRITTEN APPROVAL OF BEL FUSE INC.

ELECTRICAL CHARACTERISTICS @25°C

RoHS



TURNS RATIO PHY : LINE POLARITY □CL INTERWINDING CAPACITANCE, C _{ww} INSERTION LOSS 0.3MHz - 1MHz 1MHz - 65MHz 65MHz - 100MHz 100MHz - 125MHz RETURN LOSS @100ΩHM 0.5MHz - 40MHz 40MHz - 100MHz CROSSTALK 0.3MHz - 100MHz CM TO CM REJ 0.3MHz - 100MHz CM TO DM REJ 0.3MHz - 100MHz BALANCED DC LINE CURRENT HIPOT DESIGNED FOR USE IN EXTENDED TEMPERATURE APPLICATIONS	1CT : 1CT ±2% PER DOT CONVENTION 100kHz, 100mV 350uH MIN WITH 11mA DC BIAS 120uH MIN WITH 19mA DC BIAS @1MHz, 20mV 30pF MAX 1.1dB MAX 0.8dB MAX 1.0dB MAX 1.2dB MAX 18dB MIN 12-20LOG(f/80MHz)dB MIN 33-20LOG(f/100MHz)dB MIN 30dB MIN 35dB MIN 720mA MAX @57VDC CONTINUOUS 1.2A MAX @57VDC FOR 200ms 1500 V _{rms}
--	---

SCHEMATIC

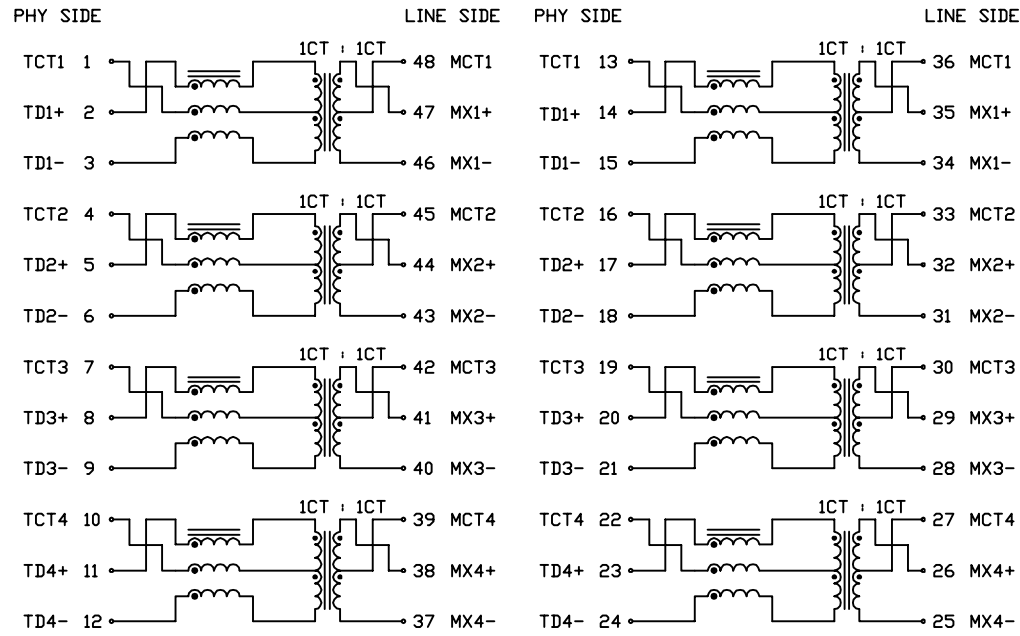

ORIGINATED BY	DATE
Roger Shea	2017-08-01
DRAWN BY	DATE
ZC Guo	2017-08-01

TITLE
ELECTRICAL SPECIFICATION

PART NO. / DRAWING NO.
S558-5500-77
FILE NAME
S558550077A.DWG

STANDARD DIM.	[] METRIC DIM. AS REF.
TOL. IN INCH	UNIT : INCH [mm]
.X	SCALE : N/A
.XX	SIZE : A4
.XXX	

REV. : PA	PAGE : 2

THE INFORMATION CONTAINED HEREIN IS CONSIDERED "PROPRIETARY" TO BEL FUSE INC. AND SHALL NOT BE COPIED, REPRODUCED OR DISCLOSED WITHOUT THE WRITTEN APPROVAL OF BEL FUSE INC.

SUGGESTED PCB PAD LAYOUT

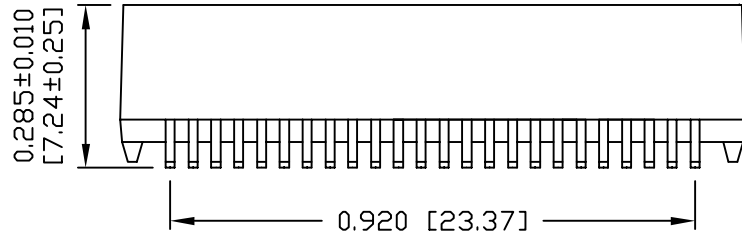
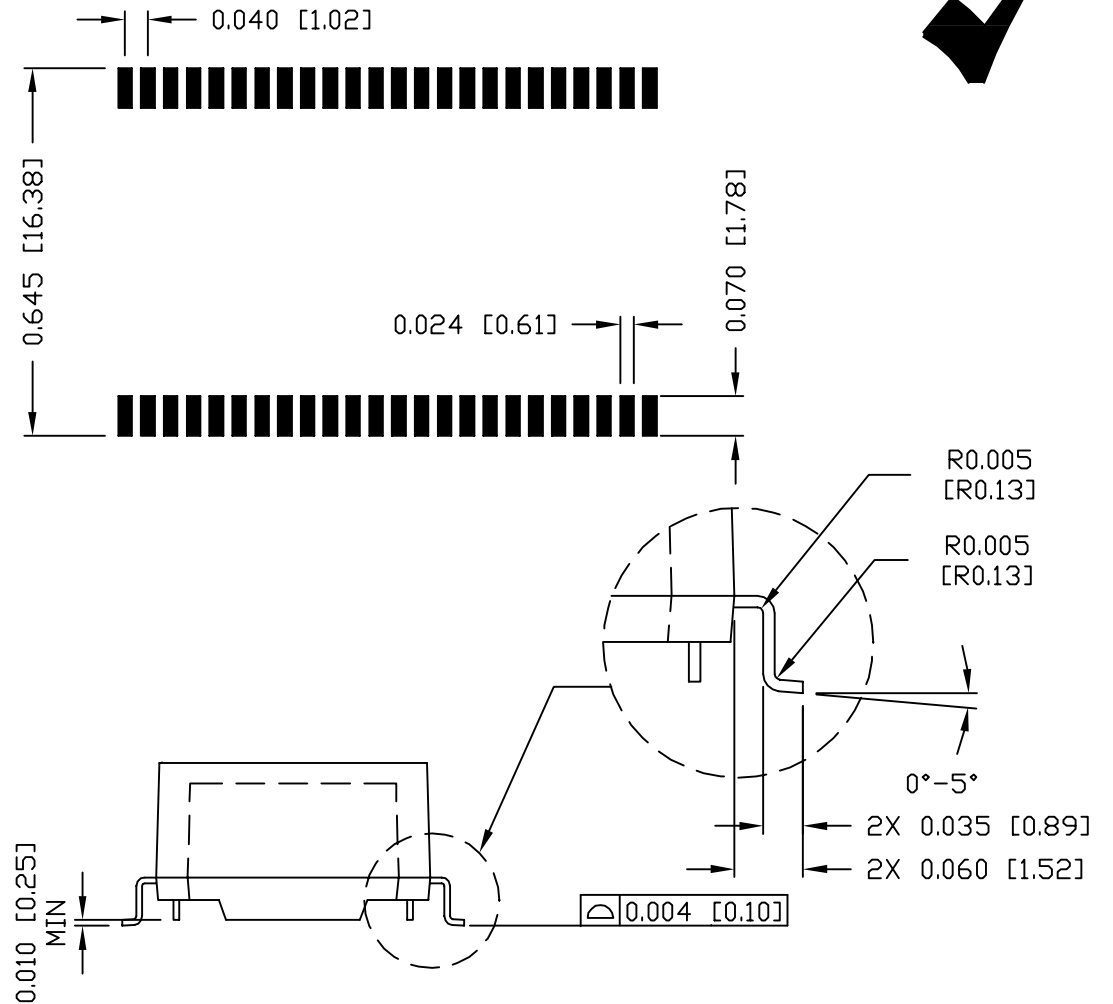
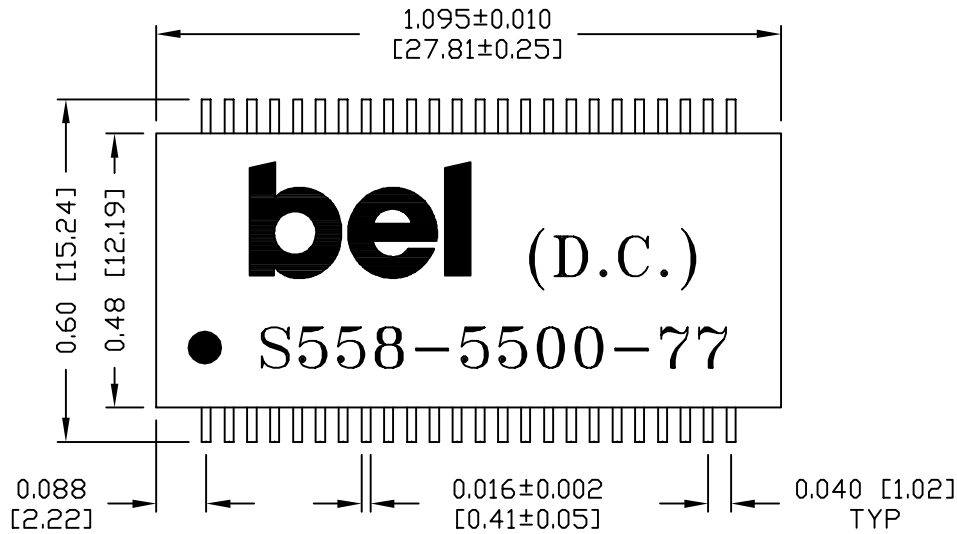

NOTES:

- STANDARD MARKING REFER TO DOC. HAND-WORK-04.
- PACKAGE CODE: "QVS001".

ORIGINATED BY	DATE	TITLE	PART NO. / DRAWING NO.	STANDARD DIM.	[] METRIC DIM. AS REF.	REV. : PA	PAGE : 3
Lawrence Tsang	2017-08-01	MECHANICAL OUTLINE	S558-5500-77	TOL. IN INCH	UNIT : INCH [mm]	 POWER PROTECT CONNECT	
DRAWN BY	DATE		FILE NAME	.X	SCALE : N/A		
ZC Guo	2017-08-01		S558550077PA.DWG	.XX ±0.01	SIZE : A4		
				.XXX ±0.005			