

DASH NUMBER	CABLES ACCOMMODATED	ASSEMBLE PER
-23	275-3930, MICRODOT	TAI-127
-24	202-3934, MICRODOT	TAI-125
-24A	9530A5117, RAYCHEM	TAI-127
-27	202-3927, MICRODOT <sup>5</sup> 73-1317911-1, SYLVANIA	TAI-125
-29	TWC-124-1A TWC-78-1	
-30	8441, BELDEN <sup>4</sup> 761A, W.E.CO.	
-32	TRC-50-1	TAI-127
-33	TRC-75-1	
-43	250-4044/250-4045 293-3930 MICRODOT	TAI-174
-45	10602, RAYCHEM	TAI-125
-47	MI7/176-00002 <sup>5</sup>	
-49	TWAC-78-1F2 <sup>5</sup>	
-55	TWCP-124-3 <sup>4</sup>	TAI-174
-56	GC875GC1, GRUMMAN	
-57	GC875GB1, GRUMMAN	
-58	GC875TM24H, GRUMMAN	TAI-125

DATA CONTAINED IN THIS DOCUMENT IS PROPRIETARY TO TROMPETER ELECTRONICS INC. AND SHALL NOT BE DISCLOSED, COPIED OR USED FOR PROCUREMENT OR MANUFACTURE WITHOUT EXPRESS WRITTEN PERMISSION.

**REVISIONS**

REV	DESCRIPTIONS	DATE	APPROVED
P	REVISED PER ECO #16414	8/15/07	AWMC

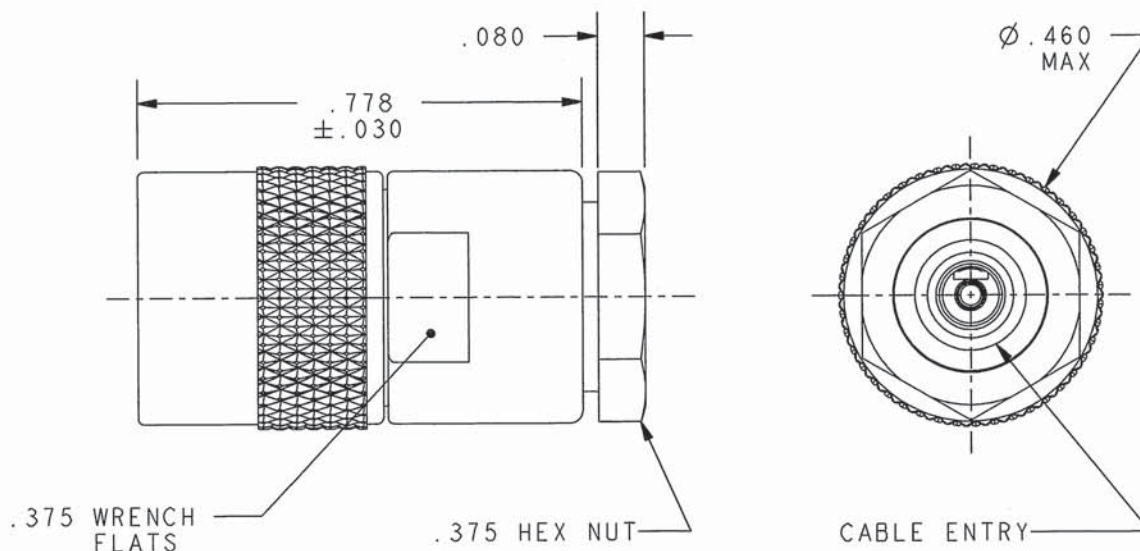

-29 SHOWN

<sup>5</sup> .187 LARGE JACKET SLITS MAY BE REQUIRED FOR EASE OF ASSEMBLY

<sup>4</sup> NOT WRENCH CRIMP

3. CONCENTRIC TWINAX/TRIAX SUBMINIATURE THREADED TTM CABLE PLUG
2. IF SAFETY WIRE TYPE REQUIRED ADD SUFFIX "S" TO MODEL NUMBER (PL3155S)
1. FINISH: NICKEL

NOTES: UNLESS OTHERWISE SPECIFIED.

INTERPRET DRAWING PER MIL-STD-100. DIMENSIONS ARE IN INCHES AND INCLUDE FINISH THICKNESS UNLESS OTHERWISE SPECIFIED.		TOL: UNLESS SPECIFIED. .XX ± .02 .XXX ± .010 ANGLE ± 1°			
DRN	JLM 7-19-07	MATERIAL:	TITLE:		
CHK	COG 8/13/07	FINISH:	PL3155/PL3155S		
MANUF		SIZE	CAGE CODE	DRAWING NO.	REV.
APPROV	JLM 8/14/07	A	14949	310-0047	P
PROJ FILE NO.	310-0047	SCALE	3/1	DATE	8/5/80
NEXT ASSY		DO NOT SCALE DWG		SHEET	IC