

NOTES:

- 1.0 ELECTRICAL SPECIFICATIONS:
- 1.1 FREQUENCY RANGE: 2 to 8 GHz
- 1.2 VSWR: $\leq 1.10:1$

DRAWING NUMBER
ADT-2639-NF-SCF-02
REV.
A

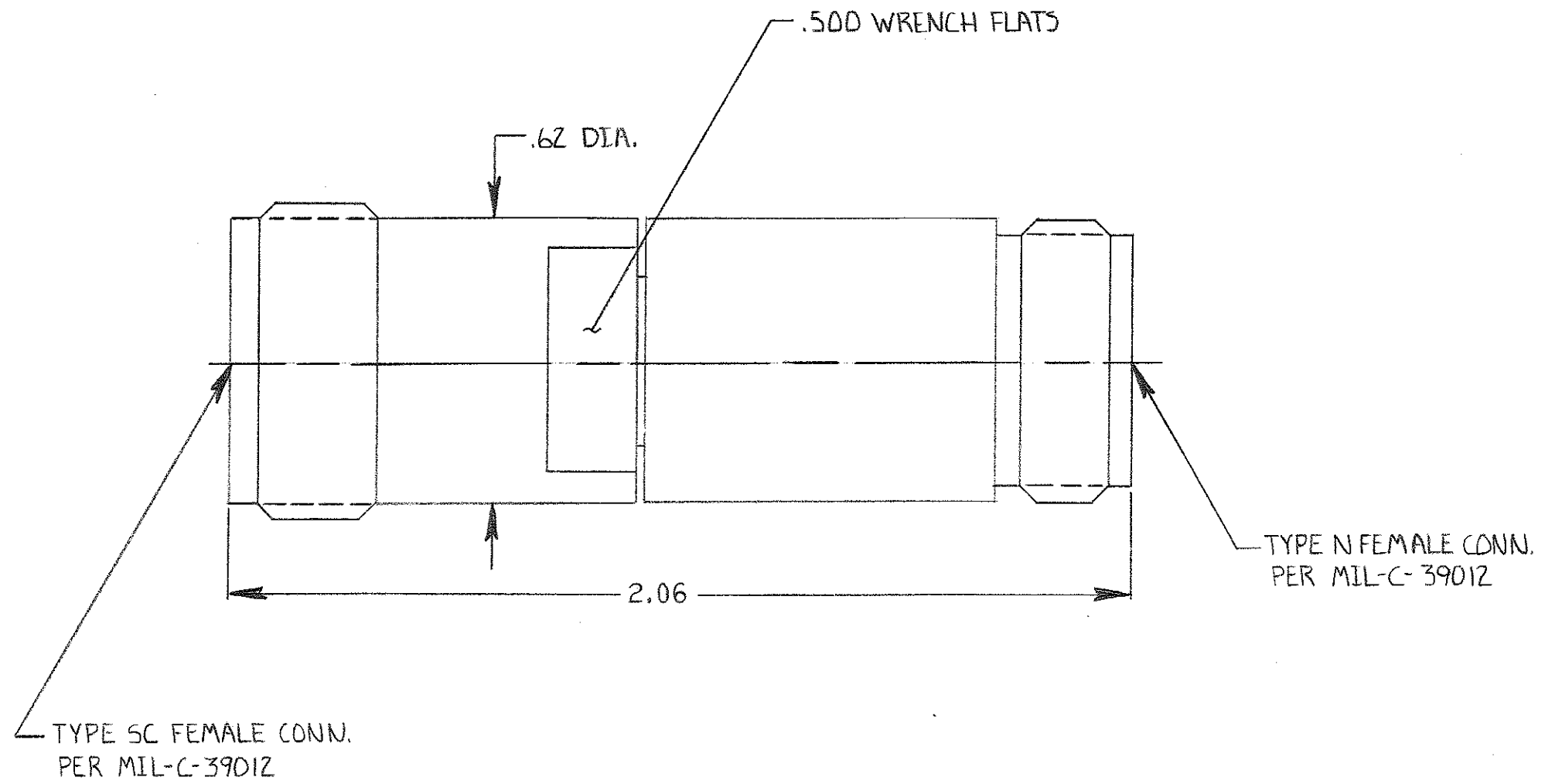

REV	DESCRIPTION	DATE
-	RELEASED	
-1	UPDATE MDD, ND	2-21-91
A	ECN 12378	1-20-93

UNLESS OTHERWISE NOTED DIMENSIONS ARE IN INCHES AND AFTER PLATING TOLERANCES ARE: 3 PLACE DECIMALS $\pm .005$ 2 PLACE DECIMALS $\pm .02$ FRACTIONS $\pm 1/64$ PARALLELITY: T.I.R. _____ FLATNESS: T.I.R. _____ CONCENTRICITY: T.I.R. _____ ANGLES AND PERPENDICULARITY: $\pm 1^\circ$		MIDWEST MICROWAVE	
		DRAWN/DATE 9-28-90 D. M. E.	TITLE ADAPTER
CHECKED/DATE AS 9-28-90		ENG./DATE Ac 9-28-90	MODEL NUMBER ADT-2639-NF-SCF-02
APPROVED/DATE 		FSCH NO. 34078	SCALE: 3:1 SHEET 1 of 1
NOTICE: The information contained in this drawing is proprietary and must not be used without the permission of Midwest Microwave.			