

CT814AYF Series

From 10 μ H to 1500 μ H



CHARACTERISTICS

Description: SMD (unshielded) power inductor.
Applications: LCD televisions, PC notebooks, portable communication equipment, DC/DC converters, etc.
Operating Temperature: -30° to +100°C
Inductance Tolerance: $\pm 10\%$, $\pm 20\%$
Saturation Current: This indicates the value of current when the inductance is 10% lower than it's initial value at D.C. superposition or D.C. current.
Temperature Current: To load current onto the components under normal ambience, which cause the temp., change as $\Delta T=40^{\circ}\text{C}$ or more lower current.
Testing: Inductance is tested on an HP4285A at 100KHz, 0.25V.
Packaging: Tape & Reel.
Marking: Parts are marked with inductance code.
Miscellaneous: **RoHS Compliant.**
Additional Information: Additional electrical & physical information available upon request.
Samples available. See website for ordering information.

SPECIFICATIONS

Part numbers are marked to indicate tolerance available.
 K = $\pm 10\%$, M = $\pm 20\%$

Part Number	Inductance (μ H)	L Test Freq. (KHz)	DCR Max. (Ω)	Saturation Current (A)	Temp. Current (A)
CT814AYF-100M	10	100	0.047	2.60	4.50
CT814AYF-120M	12	100	0.050	2.48	4.20
CT814AYF-150M	15	100	0.058	2.27	3.80
CT814AYF-180M	18	100	0.067	2.15	3.40
CT814AYF-220M	22	100	0.075	2.00	3.00
CT814AYF-270M	27	100	0.087	1.84	2.60
CT814AYF-330M	33	100	0.095	1.72	2.40
CT814AYF-390M	39	100	0.120	1.58	2.20
CT814AYF-470K	47	100	0.150	1.44	2.00
CT814AYF-560K	56	100	0.180	1.28	1.88
CT814AYF-680K	68	100	0.200	1.20	1.80
CT814AYF-820K	82	100	0.230	1.09	1.68
CT814AYF-101K	100	100	0.270	1.05	1.60
CT814AYF-121K	120	100	0.330	0.92	1.40
CT814AYF-151K	150	100	0.400	0.80	1.20
CT814AYF-181K	180	100	0.530	0.73	1.02
CT814AYF-221K	220	100	0.600	0.69	0.92
CT814AYF-271K	270	100	0.840	0.60	0.84
CT814AYF-331K	330	100	1.000	0.53	0.78
CT814AYF-391K	390	100	1.090	0.49	0.72
CT814AYF-471K	470	100	1.250	0.46	0.64
CT814AYF-561K	560	100	1.630	0.41	0.58
CT814AYF-681K	680	100	1.900	0.38	0.54
CT814AYF-821K	820	100	2.440	0.34	0.50
CT814AYF-102K	1000	100	2.800	0.31	0.44
CT814AYF-122K	1200	100	3.670	0.27	0.40
CT814AYF-152K	1500	100	4.370	0.25	0.36

PHYSICAL DIMENSIONS

Size	A Max.	B Max.	C Ref.	D Max.	E Typ.
mm	9.7	11.5	9.0	5.0	2.8
inches	0.38	0.45	0.35	0.20	0.11

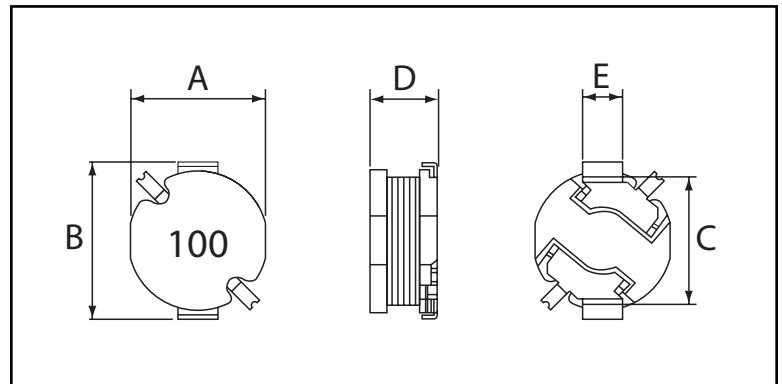

PAD LAYOUT

