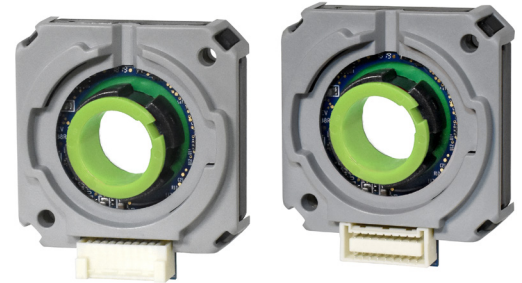

SERIES: AMT13A | **DESCRIPTION:** MODULAR INCREMENTAL ENCODER

FEATURES

- patented capacitive ASIC technology
- low power consumption
- incremental resolutions up to 4096 PPR
- differential line driver versions
- compact modular package with locking hub for ease of installation
- radial and axial cable connections
- -40~125°C operating temperature

ELECTRICAL

| parameter | conditions/description | min | typ | max | units |
|------------------------------|------------------------------|---------|-----|-----|-------|
| power supply | VDD | 4.5 | 5 | 5.5 | V |
| start-up time ¹ | | | 200 | | ms |
| current consumption | with unloaded output | | 8 | | mA |
| single ended channels | output high level | VDD-0.1 | | | V |
| | output low level | | | 0.1 | V |
| | output current (per channel) | | | 15 | mA |
| | rise/fall time | | 8 | | ns |
| differential RS-422 channels | output high level | 3 | | | V |
| | output low level | | | 0.1 | V |
| | output current (per channel) | | | 25 | mA |
| | rise/fall time | 7 | 11 | 20 | ns |

Note: 1. Encoder must be stationary during start-up.

INCREMENTAL CHARACTERISTICS

| parameter | conditions/description | min | typ | max | units |
|--|---|-----|-----|-----|---------|
| channels | CMOS Voltage (S) A, B Quadrature Line Driver (Q) A, \bar{A} , B, \bar{B} | | | | |
| waveform | CMOS voltage square wave | | | | |
| phase difference | A leads B for CCW rotation (viewed from front) | | | | |
| quadrature resolutions ² | 96, 192, 200, 250, 384, 400, 500, 512 768, 800, 1000, 1024, 1600, 2000, 2048, 4096 | | | | PPR |
| accuracy | | | 0.2 | | degrees |
| quadrature duty cycle (at each resolution) | 96, 192, 384 | 49 | 50 | 51 | % |
| | 200, 250, 400, 768, 800 | 48 | 50 | 52 | % |
| | 500, 1000, 1600 | 46 | 50 | 54 | % |
| | 512, 1024, 2048, 4096 | 50 | 50 | 50 | % |
| | 2000 | 44 | 50 | 56 | % |

Notes: 2. Default resolution set to 4096 PPR. All resolutions are listed as pre-quadrature, meaning the final number of counts is PPR x 4.

MECHANICAL

| parameter | conditions/description | min | typ | max | units |
|---------------------------------------|--|------|---------------|------|-------|
| motor shaft length | | 13.5 | | | mm |
| motor shaft tolerance | | | NOM +0/-0.015 | | mm |
| weight | weight varies by configuration | | 26 | | g |
| hub set screw to shaft torque | set screw size: M2.5x0.45 | | 3 | | in-lb |
| axial play | | | | ±0.3 | mm |
| rotational speed (at each resolution) | 96, 192, 200, 250, 384, 400, 500, 512, 800, 1000, 1024, 2048 | | | 8000 | RPM |
| | 768, 1600, 2000, 4096 | | | 4000 | RPM |

ENVIRONMENTAL

| parameter | conditions/description | min | typ | max | units |
|-----------------------|--|-----|-----|-----|-------|
| operating temperature | | -40 | | 125 | °C |
| humidity | non-condensing | | | 85 | % |
| vibration | 10-500 Hz, 5 minute sweep, 2 hours on each XYZ | | | 5 | G |
| shock | 3 pulses, 6 ms, 3 on each XYZ | | | 200 | G |
| RoHS | yes | | | | |

WAVEFORMS

Figure 1

Quadrature signals with index showing counter-clockwise rotation

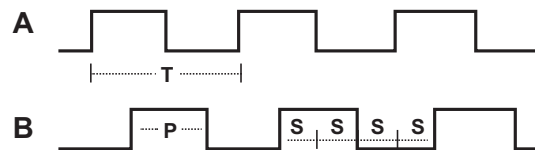

The following parameters are defined by the resolution selected for each encoder. The encoders resolution is listed as Pulses Per Revolution (PPR), which is the number of periods (or high pulses) over the encoders revolution.

| Parameter | Description | Expression | Units | Notes |
|-----------|-----------------|------------|-----------------------|--|
| PPR | resolution | | Pulses Per Revolution | This is the user selected value and the format all resolutions are listed in |
| CPR | counts | PPR x 4 | Counts Per Revolution | This is the number of quadrature counts the encoder has |
| T | period | 360/R | mechanical degrees | |
| P | pulse width | T/2 | mechanical degrees | |
| S | A/B state width | T/4 | mechanical degrees | This is the width of a quadrature state |

Note: For more information regarding PPR, CPR, or LPR (Lines Per Revolution) view <https://www.cuidevices.com/blog/what-is-encoder-ppr-cpr-and-lpr>

PART NUMBER KEY

For customers that prefer a specific AMT13A configuration, please reference the custom configuration key below.

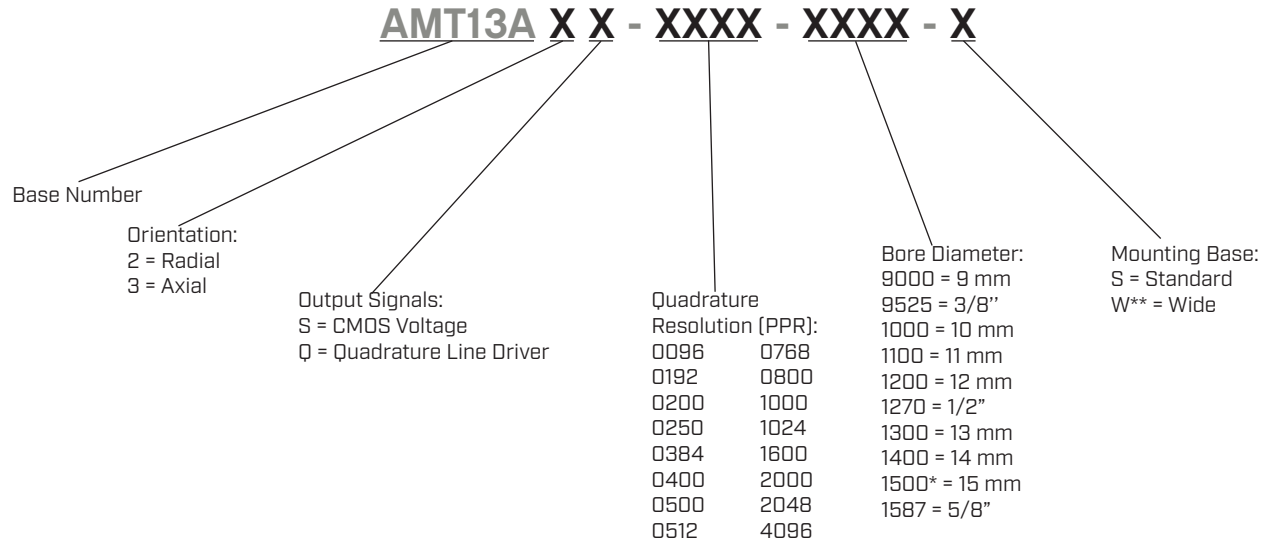

*15 mm bore diameter option only available as custom configuration.

**Wide base not included in kits.

AMT13A-V KITS

In order to provide maximum flexibility for our customers, the AMT13A series is provided in kit form standard. This allows the user to implement the encoder into a range of applications using one sku#, reducing engineering and inventory costs. AMT13A kit includes all items shown below.

ORDERING GUIDE

AMT13A_{XX}-V

Orientation:
2 = Radial
3 = Axial

Output Signals:
S = CMOS Voltage
Q = Quadrature Line Driver

| SHAFT ADAPTERS | | | | | | | |
|----------------|--------|--------|-------|--------|--------|-------|-------|
| | | | | | | | |
| 9 mm | 3/8 in | 10 mm | 11 mm | 12 mm | 1/2 in | 13 mm | 14 mm |
| Light Blue | Orange | Purple | Gray | Yellow | Green | Red | Blue |

| AMT13A | ALIGNMENT TOOL* | PLACEMENT TOOL | ALLEN WRENCH |
|--|-----------------|----------------|--------------|
| | | | |
| Shaft adapter is not needed for 5/8" shaft | | | |

*Alignment Tool comes pre-installed on all AMT13A Series.

RESOLUTION SETTINGS

1 = On, 0 = Off

| Resolution (PPR) | Maximum RPM | 1 | 2 | 3 | 4 |
|------------------|-------------|---|---|---|---|
| 4096 | 4000 | 0 | 0 | 0 | 0 |
| 2048 | 8000 | 0 | 0 | 1 | 0 |
| 2000 | 4000 | 1 | 0 | 0 | 0 |
| 1600 | 4000 | 0 | 1 | 0 | 0 |
| 1024 | 8000 | 0 | 0 | 0 | 1 |
| 1000 | 8000 | 1 | 0 | 1 | 0 |
| 800 | 8000 | 0 | 1 | 1 | 0 |
| 768 | 4000 | 1 | 1 | 0 | 0 |
| 512 | 8000 | 0 | 0 | 1 | 1 |
| 500 | 8000 | 1 | 0 | 0 | 1 |
| 400 | 8000 | 0 | 1 | 0 | 1 |
| 384 | 8000 | 1 | 1 | 1 | 0 |
| 250 | 8000 | 1 | 0 | 1 | 1 |
| 200 | 8000 | 0 | 1 | 1 | 1 |
| 192 | 8000 | 1 | 1 | 0 | 1 |
| 96 | 8000 | 1 | 1 | 1 | 1 |

DIP switch:

Example setting: 1000 PPR

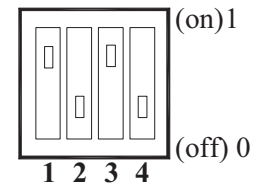

ENCODER INTERFACE

| CONNECTOR PINOUT | | | | |
|------------------|-----------|-----------|-----------|-----------|
| Function | | | | |
| # | AMT13A2S | AMT133AS | AMT13A2Q | AMT13A3Q |
| 1 | N/A | N/A | N/A | N/A |
| 2 | N/A | N/A | N/A | N/A |
| 3 | N/A | N/A | N/A | N/A |
| 4 | GND | GND | GND | GND |
| 5 | N/A | N/A | N/A | N/A |
| 6 | +5 V | +5 V | +5 V | +5 V |
| 7 | N/A | N/A | N/A | N/A |
| 8 | A+ | A+ | A+ | A+ |
| 9 | N/A | N/A | A- | A- |
| 10 | B+ | B+ | B+ | B+ |
| 11 | N/A | N/A | B- | B- |
| 12 | N/A | N/A | N/A | N/A |
| 13 | N/A | N/A | N/A | N/A |
| 14 | N/A | N/A | N/A | N/A |
| 15 | N/A | N/A | N/A | N/A |
| 16 | N/A | N/A | N/A | N/A |
| 17 | N/A | N/A | N/A | N/A |
| 18* | NOISE GND | NOISE GND | NOISE GND | NOISE GND |

*Pin 18 is not connected internally for standard encoders. Contact CUI Devices for support with high noise applications.

AMT13A2

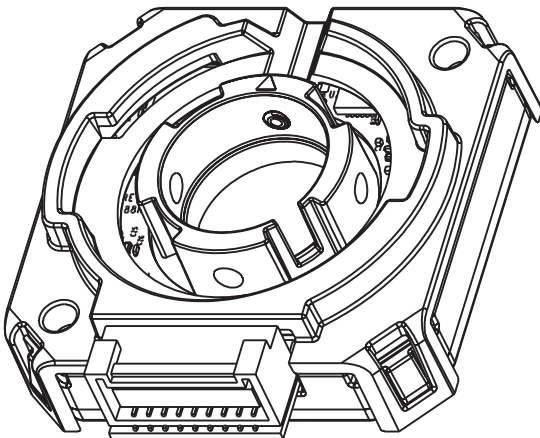

AMT13A3

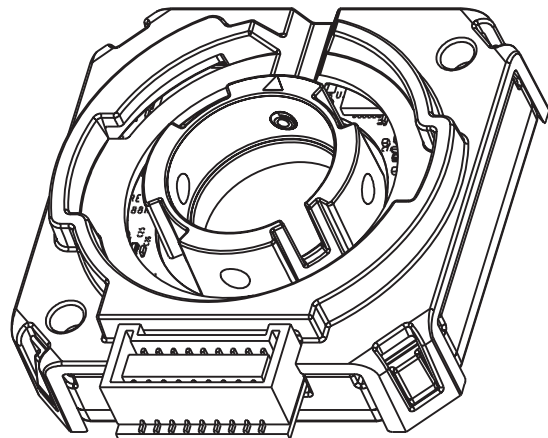

Mating Connector:
JST ZPDR-18V-S

MECHANICAL DRAWING

units: mm
tolerance:
X.XX ±0.25 mm
hole dia: ±0.08 mm

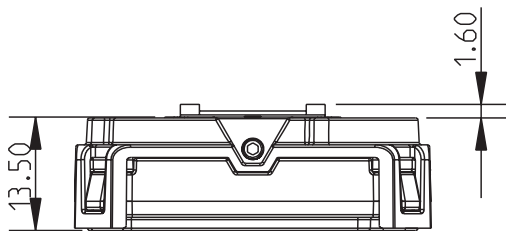
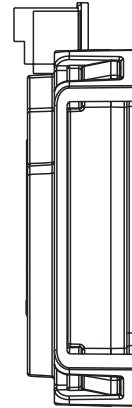
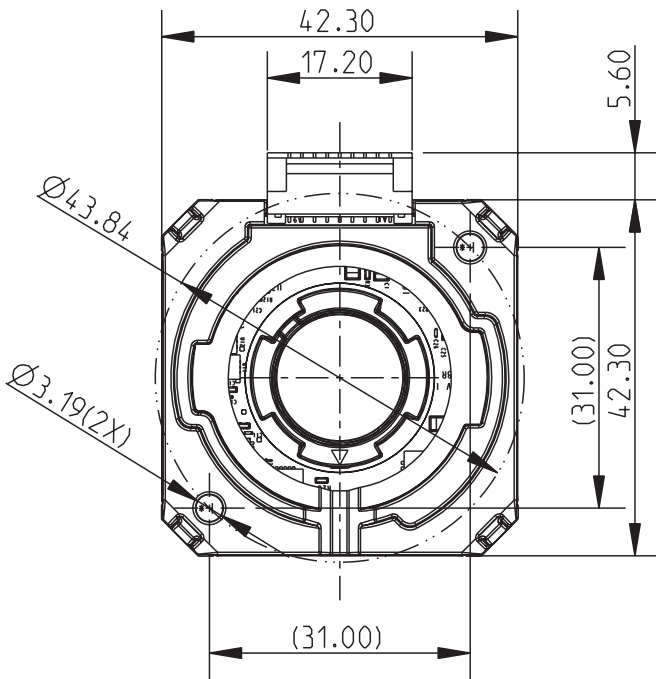
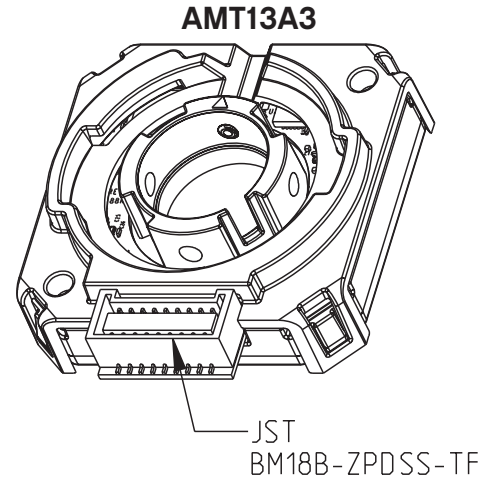
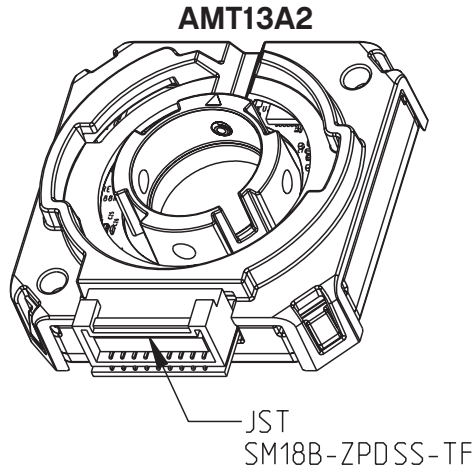

MECHANICAL DRAWING (WIDE BASE)

units: mm
 tolerance:
 X.XX ±0.25 mm
 hole dia: ±0.08 mm

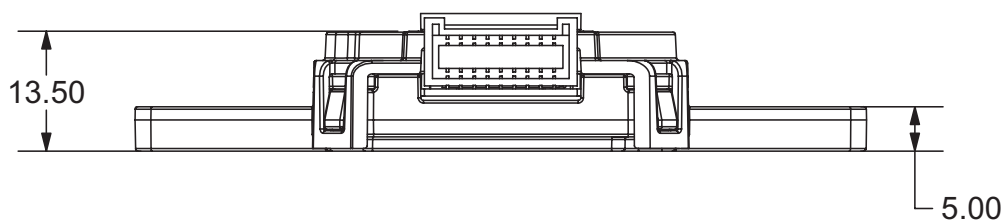
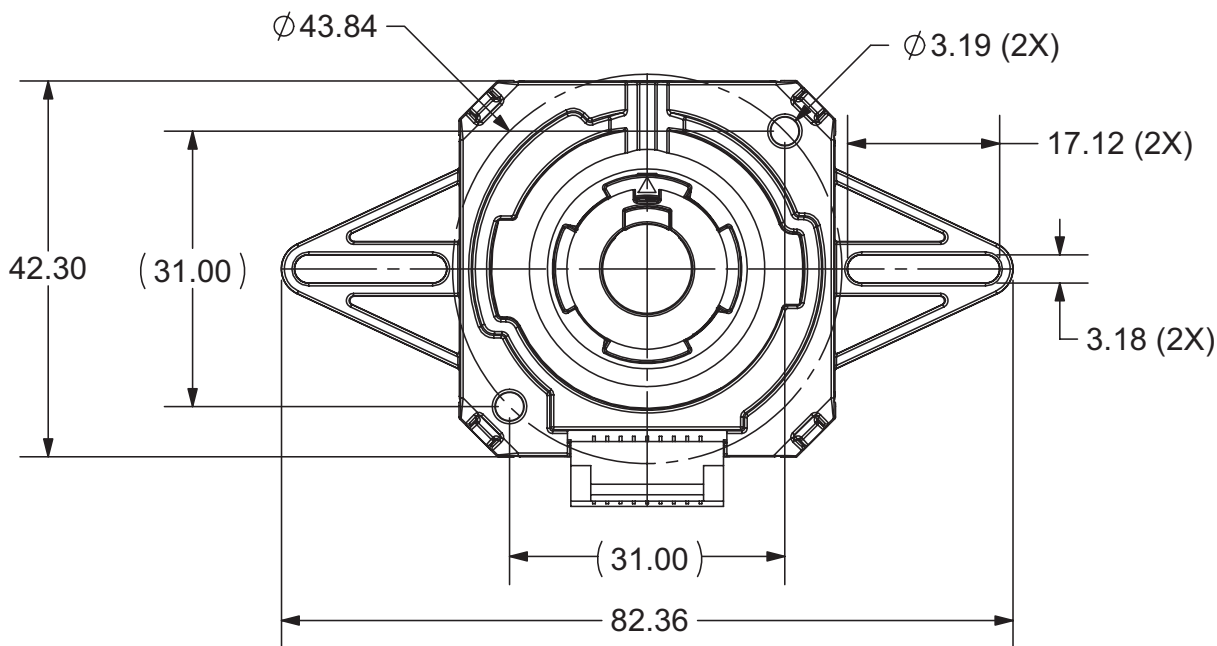
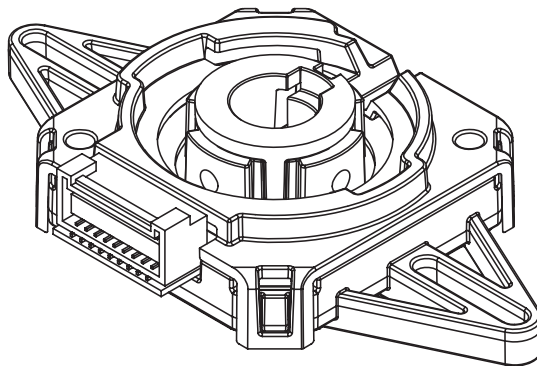

ASSEMBLY PROCEDURE

STEP 1

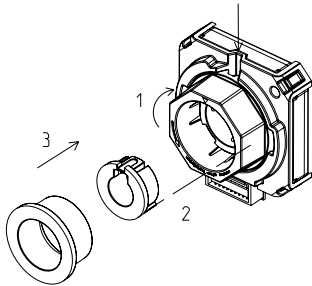

1. Begin by rotating the pre-installed alignment tool clockwise and completely to the right so that the pre-installed shaft set screw is visible.
2. Select the appropriately sized shaft adapter and insert it into the encoder making sure the adapter is properly aligned with the keyway in the metal hub. No adapter is needed for a 5/8" motor shaft.
3. Select the placement tool and insert it into the encoder. This placement tool holds the encoder's hub and shaft adapter in the proper position for installation onto the motor shaft.

STEP 2

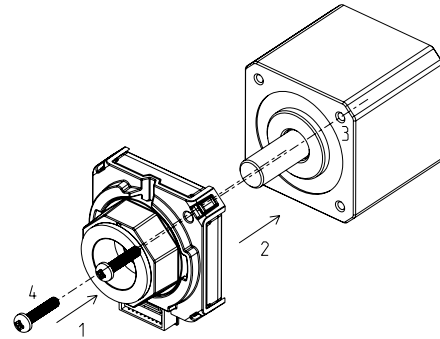

1. Slide the encoder onto the motor shaft applying force only to the placement tool to maintain proper alignment of the encoder's hub and shaft adapter.
2. Press until the encoder sits flush with the motor body.
3. Once in contact with the motor body, rotate the encoder until the mounting holes are aligned with the proper bolt circle.
4. Insert screws and fasten the encoder to the motor.

STEP 3

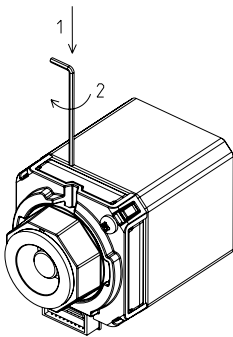

1. Insert the Allen Wrench into the notch on the top.
2. Tighten the shaft set screw to the recommended torque settings per the spec.

STEP 4

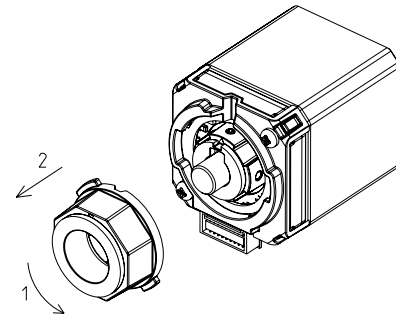

1. Rotate the placement tool and alignment tool counterclockwise until the tabs align with the openings.
2. Remove both tools from the encoder.
3. When installation is finished, the motor shaft should be rotating freely.

REVISION HISTORY

| rev. | description | date |
|------|------------------------------|------------|
| 1.0 | initial release | 07/19/2022 |
| 1.01 | logo, datasheet style update | 08/05/2022 |
| 1.02 | added wide base drawing | 01/12/2023 |

The revision history provided is for informational purposes only and is believed to be accurate.



CUI Devices offers a one (1) year limited warranty. Complete warranty information is listed on our website.

CUI Devices reserves the right to make changes to the product at any time without notice. Information provided by CUI Devices is believed to be accurate and reliable. However, no responsibility is assumed by CUI Devices for its use, nor for any infringements of patents or other rights of third parties which may result from its use.

CUI Devices products are not authorized or warranted for use as critical components in equipment that requires an extremely high level of reliability. A critical component is any component of a life support device or system whose failure to perform can be reasonably expected to cause the failure of the life support device or system, or to affect its safety or effectiveness.

cuidevices.com