

**AK1228****10~2000MHz Low Noise Mixer**

1. General Description

AK1228 is a high linearity and low noise mixer. Signal input frequency range coverage is from 10 to 2000MHz and output coverage is from 10 to 1000MHz. AK1228 can be driven by a single ended signal input and a low-power differential LO input that can be driven with a differential or single ended LO. The signal output ports are differential open drain outputs. The analog circuit characteristics and power consumption performances can be optimized by the resistance connected to the BIAS Pin.

2. Features

- Input Frequency: 10MHz to 2000MHz
- Output Frequency: 10MHz to 1000MHz
- Operating Supply Current: 4.5mA to 10.5mA
- Analog Circuit Characteristics: Current Consumption:10.5mA, IIP3:+12dBm, Gain:4dBm, NF:8.5dB
- LO Input Level: -10 to +5dBm
- Operating Supply Voltage: 2.7 to 5.25V
- Package: 16pin UQFN (0.5mm pitch, 3mm × 3mm × 0.60mm)
- Operating Temperature: -40 to 85°C

3. Applications

- Two-way Radios (PMR/LMR)
- Radio Communications for disaster prevention
- Marine Radios
- Amateur Radios
- Specified Low Power Radios
- Telemeter, Telecontrol
- Wireless Microphone

4. Table of Contents

1. General Description	1
2. Features	1
3. Applications	1
4. Table of Contents	2
5. Block Diagram and Pin Configurations	3
6. Pin Functions Description	4
7. Absolute Maximum Ratings	4
8. Recommended Operating Conditions	4
9. Electrical Characteristics	5
10. Typical Performance	6
11. Typical Evaluation Board Schematic	17
12. LSI Interface Schematic	18
13. Application Information	19
14. Outer Dimensions	28
15. Marking	29

5. Block Diagram and Pin Configurations

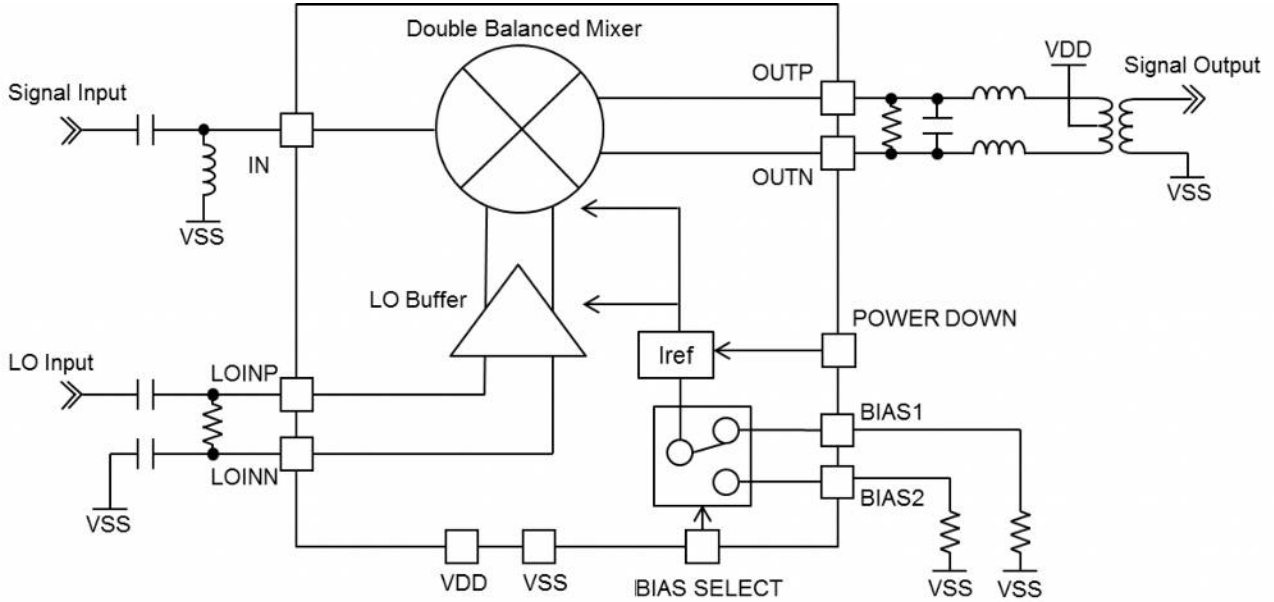

Figure 1. Block Diagram

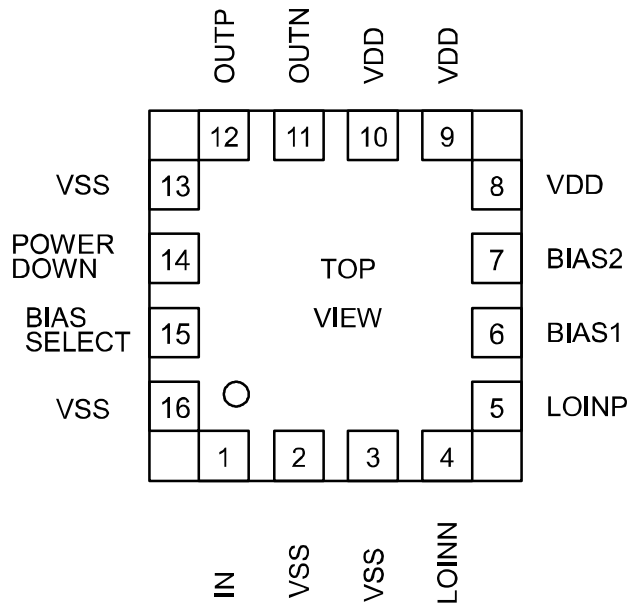

Figure 2. Package Pin Layout

6. Pin Functions Description

Table 1. Pin Function

No.	Name	I/O	Pin Function	Remarks
1	IN	AI	Signal input	Connecting a inductor between this pin and ground.
2	VSS	G	Ground pin	
3	VSS	G	Ground pin	
4	LOINN	AI	LO Input Negative	
5	LOINP	AI	LO Input Positive	
6	BIAS1	AIO	Resistance pin for current adjustment	Connecting a resistor between this pin and ground.
7	BIAS2	AIO	Resistance pin for current adjustment	Connecting a resistor between this pin and ground.
8	VDD	P	Power Supply	
9	VDD	P	Power Supply	
10	VDD	P	Power Supply	
11	OUTN	AO	Signal Output Negative	This pin is open drain output. It needs power feeding via an inductor.
12	OUTP	AO	Signal Output Positive	This pin is open drain output. It needs power feeding via an inductor.
13	VSS	G	Ground pin	
14	POWER DOWN	DI	Power Down control pin	High : Power OFF Low : Power ON
15	BIAS SELECT	DI	Bias Resistance select pin	High : BIAS2 pin is enabled Low : BIAS1 pin is enabled
16	VSS	G	Ground pin	

Note 1. The exposed pad at the center of the backside should be connected to ground.

Note 2. With the power supply voltage is not applied to VDD, do not apply a voltage to each input pin.

AI: Analog input pin	AO: Analog output pin	AIO: Analog I/O pin
P: Power supply pin	G: Ground pin	DI: Digital input pin

7. Absolute Maximum Ratings

Table 2. Absolute Maximum Ratings

Parameter	Symbol	Min.	Max.	Unit	Remarks
Supply Voltage	Vdd	-0.3	5.5	V	
Signal Input Power	INPOW		12	dBm	
LO Input Power	LOPOW		12	dBm	
Storage Temperature	Tstg	-55	125	°C	

Exceeding these maximum ratings may result in damage to the AK1228. Normal operation is not guaranteed at these extremes.

8. Recommended Operating Conditions

Table 3. Recommended Operating Range

Parameter	Symbol	Min.	Typ.	Max.	Unit	Remarks
Operating Temperature	Ta	-40		85	°C	
Supply Voltage	Vdd	2.7	5	5.25	V	

The specifications are applicable within the recommended operating range (supply voltage/operating temperature).

9. Electrical Characteristics

1. Analog Circuit Characteristics

Unless otherwise noted Signal Output = 50MHz, Output Load Resistor (R_{load}) = 2.2k Ω , V_{dd} = 2.7 to 5.25V, T_a = -40 to 85°C, LO Input Level = -10dBm to +5dBm. Test circuit is shown in Figure 3.

Table 4. Analog Circuit Characteristics

Parameter	Min.	Typ.	Max.	Unit	Remarks
Signal Input Frequency	10		2000	MHz	
LO Input Frequency	10		2000	MHz	
Signal Output Frequency	10		1000	MHz	
LO Input Power	-10	0	+5	dBm	
Current Adjustment Resistor (R_{bias})	39		100	k Ω	
IDD (R_{bias} = 39k Ω)	7.5	10.5	15	mA	The total current of VDD, OUTP pin and OUTN pin.
IDD (R_{bias} = 100k Ω)	3	4.5	6.5	mA	
IDD (POWER DOWN = V_{dd})		1	10	μ A	
IN = 600MHz, LOIN = 550MHz(0dBm), R_{bias} = 39kΩ, V_{dd} = 3V					
Conversion Gain	1.5	4	6	dB	
SSB Noise Figure (NF)		8.5	11	dB	Design guarantee value
IP1dB	-5	-1		dBm	
IIP3	8	12		dBm	Design guarantee value

2. Digital Circuit Characteristics

This table is for POWER DOWN pin and BIAS SELECT pin.

Table 5. Digital Circuit Characteristics

Parameter	Symbol	Conditions	Min.	Typ.	Max.	Unit	Remarks
High level input voltage	V_{ih}		$0.8 \times V_{dd}$			V	
Low level input voltage	V_{il}				$0.2 \times V_{dd}$	V	
High level input current	i_{ih}	$V_{ih} = V_{dd} = 5.25V$	-1		1	μ A	
Low level input current	i_{il}	$V_{il} = 0V, V_{dd} = 5.25V$	-1		1	μ A	

10. Typical Performance

Output Load Resistor (Rload) = 2.2k Ω , Vdd = 3V, Ta = 25°C, LO Input Level = 0dBm, Current Adjustment Resistor (Rbias) = 39k Ω . Test circuit is shown in Figure 3.

Table 6. Typical Performance

Parameter	Frequency	Min.	Typ.	Max.	Unit
Conversion Gain	IN = 160MHz, OUT = 70MHz, LOIN = 230MHz		3.7		dB
	IN = 400MHz, OUT = 70MHz, LOIN = 470MHz		3.7		
	IN = 800MHz, OUT = 11MHz, LOIN = 811MHz		3.3		
	IN = 1500MHz, OUT = 250MHz, LOIN = 1250MHz		2.8		
	IN = 50MHz, OUT = 450MHz, LOIN = 400MHz		2.7		
SSB Noise Figure (NF)	IN = 160MHz, OUT = 70MHz, LOIN = 230MHz		8.5		dB
	IN = 400MHz, OUT = 70MHz, LOIN = 470MHz		8.5		
	IN = 800MHz, OUT = 11MHz, LOIN = 811MHz		9.6		
	IN = 1500MHz, OUT = 250MHz, LOIN = 1250MHz		10.3		
	IN = 50MHz, OUT = 450MHz, LOIN = 400MHz		9.9		
IP1dB	IN = 160MHz, OUT = 70MHz, LOIN = 230MHz		2.0		dBm
	IN = 400MHz, OUT = 70MHz, LOIN = 470MHz		3.1		
	IN = 800MHz, OUT = 11MHz, LOIN = 811MHz		1.6		
	IN = 1500MHz, OUT = 250MHz, LOIN = 1250MHz		1.5		
	IN = 50MHz, OUT = 450MHz, LOIN = 400MHz		1.5		
IIP3	IN = 160MHz, OUT = 70MHz, LOIN = 230MHz		14.0		dBm
	IN = 400MHz, OUT = 70MHz, LOIN = 470MHz		13.7		
	IN = 800MHz, OUT = 11MHz, LOIN = 811MHz		12.0		
	IN = 1500MHz, OUT = 250MHz, LOIN = 1250MHz		10.1		
	IN = 50MHz, OUT = 450MHz, LOIN = 400MHz		13.4		

1. Current Adjustment Resistor vs. IDD, IDD vs. Gain, NF, IIP3, IP1dB

The analog circuit characteristics and power consumption performances can be optimized by the resistance connected to the BIAS Pin (Rbias). Signal Input = 600MHz, Signal Output = 50MHz, LO Input = 550MHz, Output Load Resistor (Rload) = 2.2kΩ, Vdd = 3V, Ta = 25°C, LO Input Level = 0dBm, Current Adjustment Resistor (Rbias) = 39kΩ.

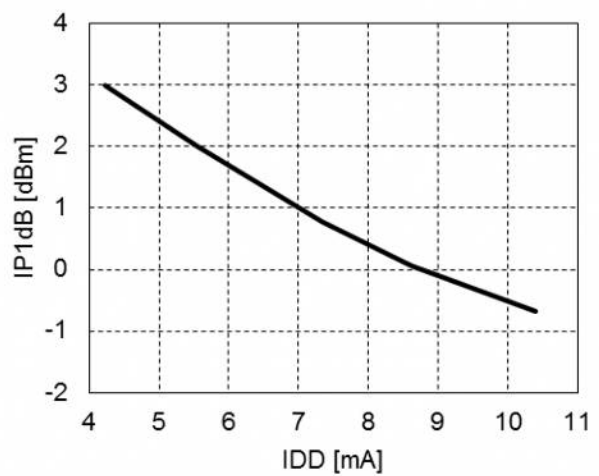
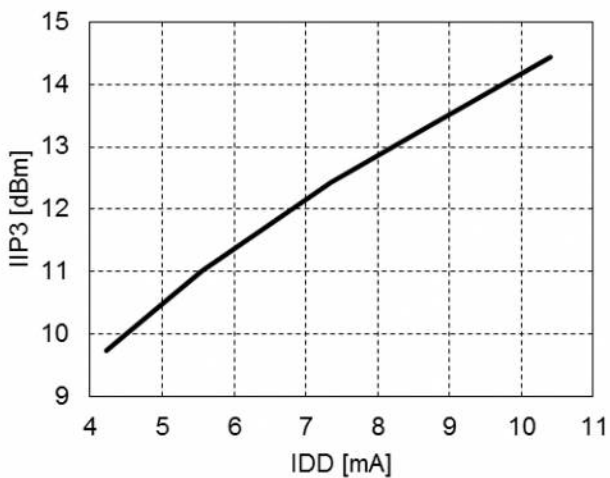
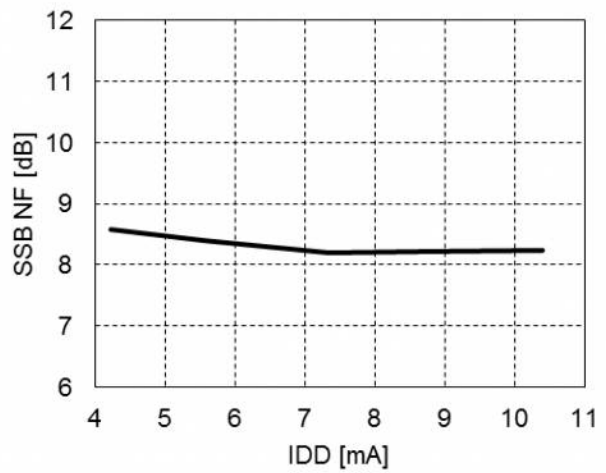
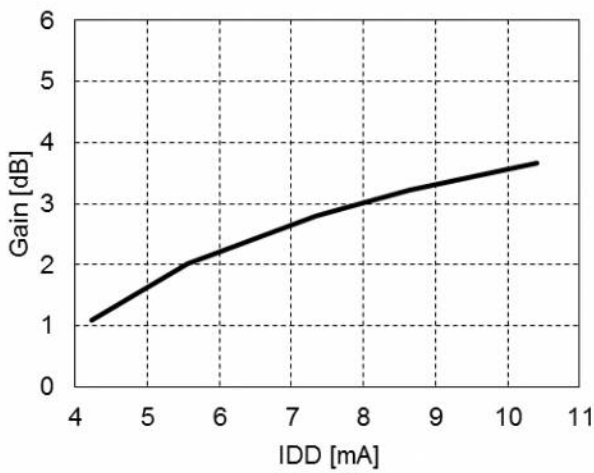
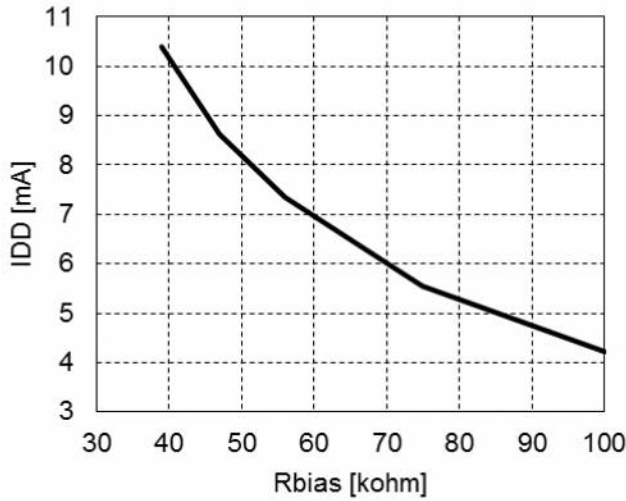

2. Temperature vs. Gain, NF, IIP3, IP1dB, IDD

Signal Input = 600MHz, Signal Output = 50MHz, LO Input = 550MHz, Output Load Resistor (Rload) = 2.2kΩ, Vdd = 3V, LO Input Level = 0dBm.

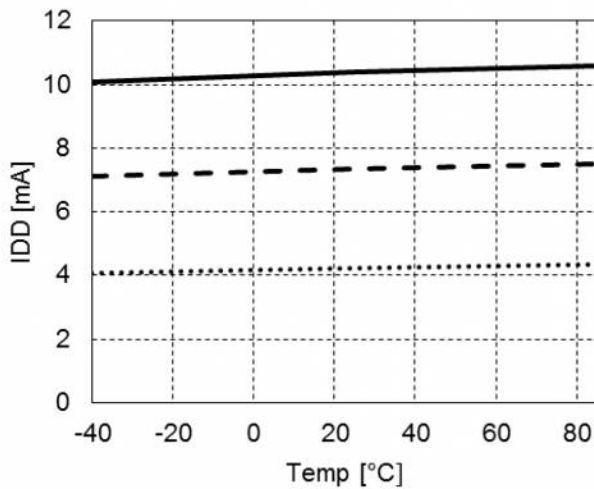
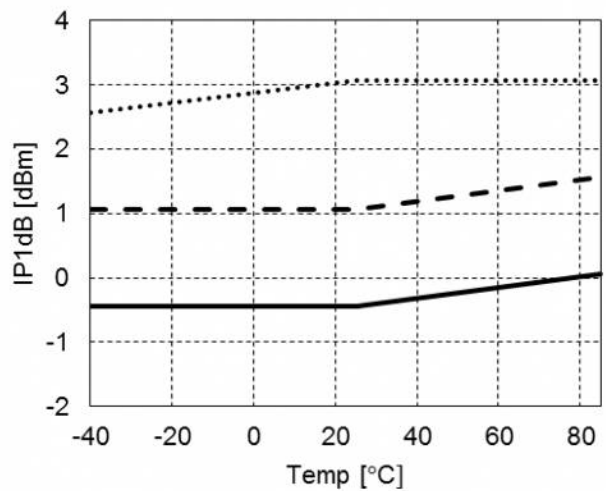
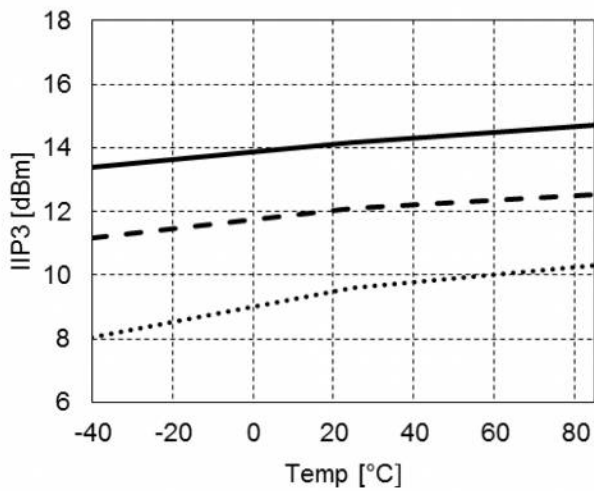
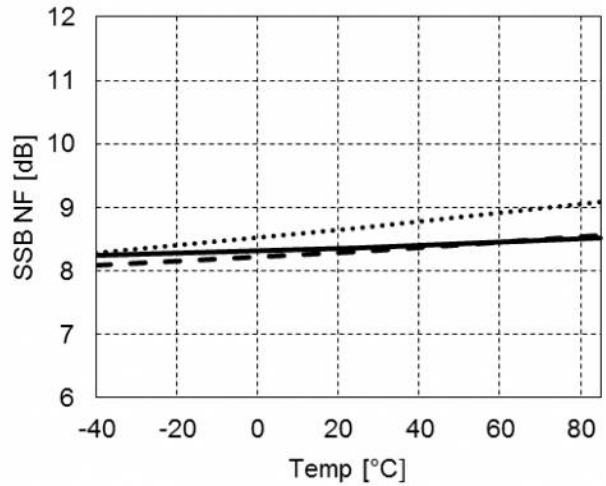
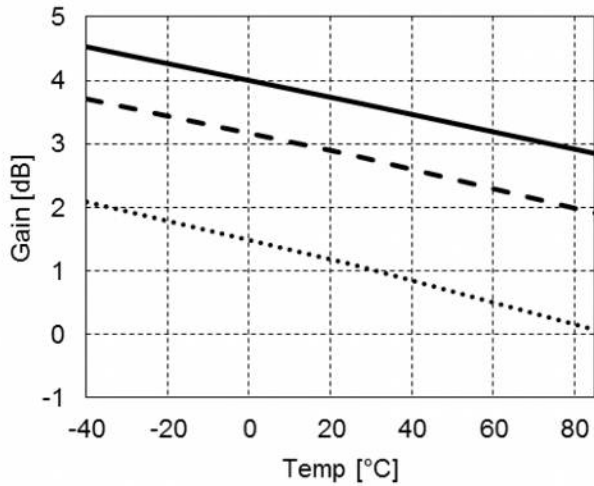

Resistance for current adjustment

- 39kΩ (≅10.5mA)
- - - -** 56kΩ (≅7.5mA)
-** 100kΩ (≅4.5mA)

3. Supply voltage vs. Gain, NF, IIP3, IP1dB, IDD

Signal Input = 600MHz, Signal Output = 50MHz, LO Input = 550MHz, Output Load Resistor (Rload) = 2.2kΩ, Ta = 25°C, LO Input Level = 0dBm.

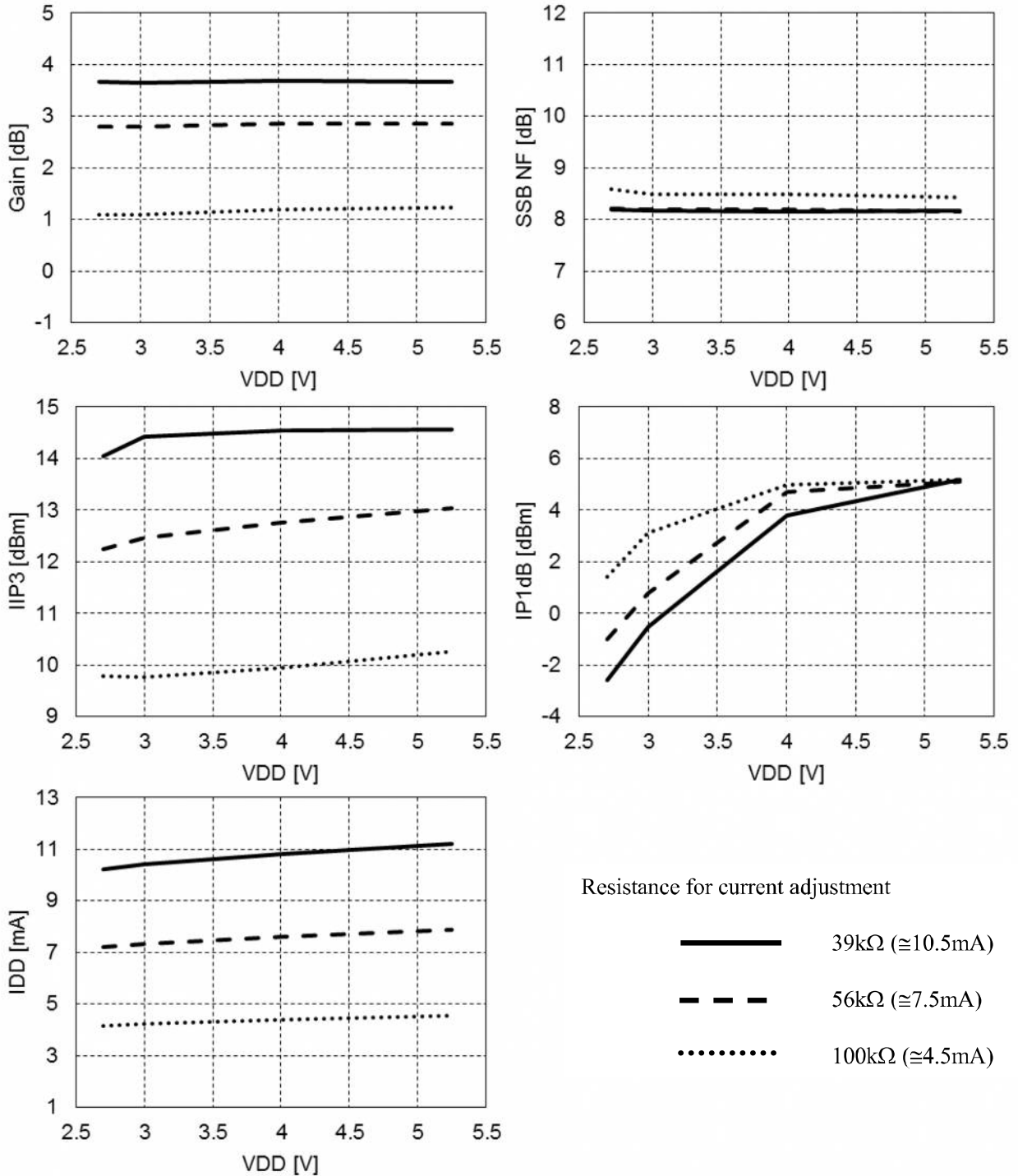

Resistance for current adjustment

- 39kΩ (≈10.5mA)
- - - 56kΩ (≈7.5mA)
- 100kΩ (≈4.5mA)

4. LO input power vs. Gain, NF, IIP3, IP1dB

Signal Input = 600MHz, Signal Output = 50MHz, LO Input = 550MHz, Output Load Resistor (Rload) = 2.2kΩ, Vdd = 3V, Ta = 25°C.

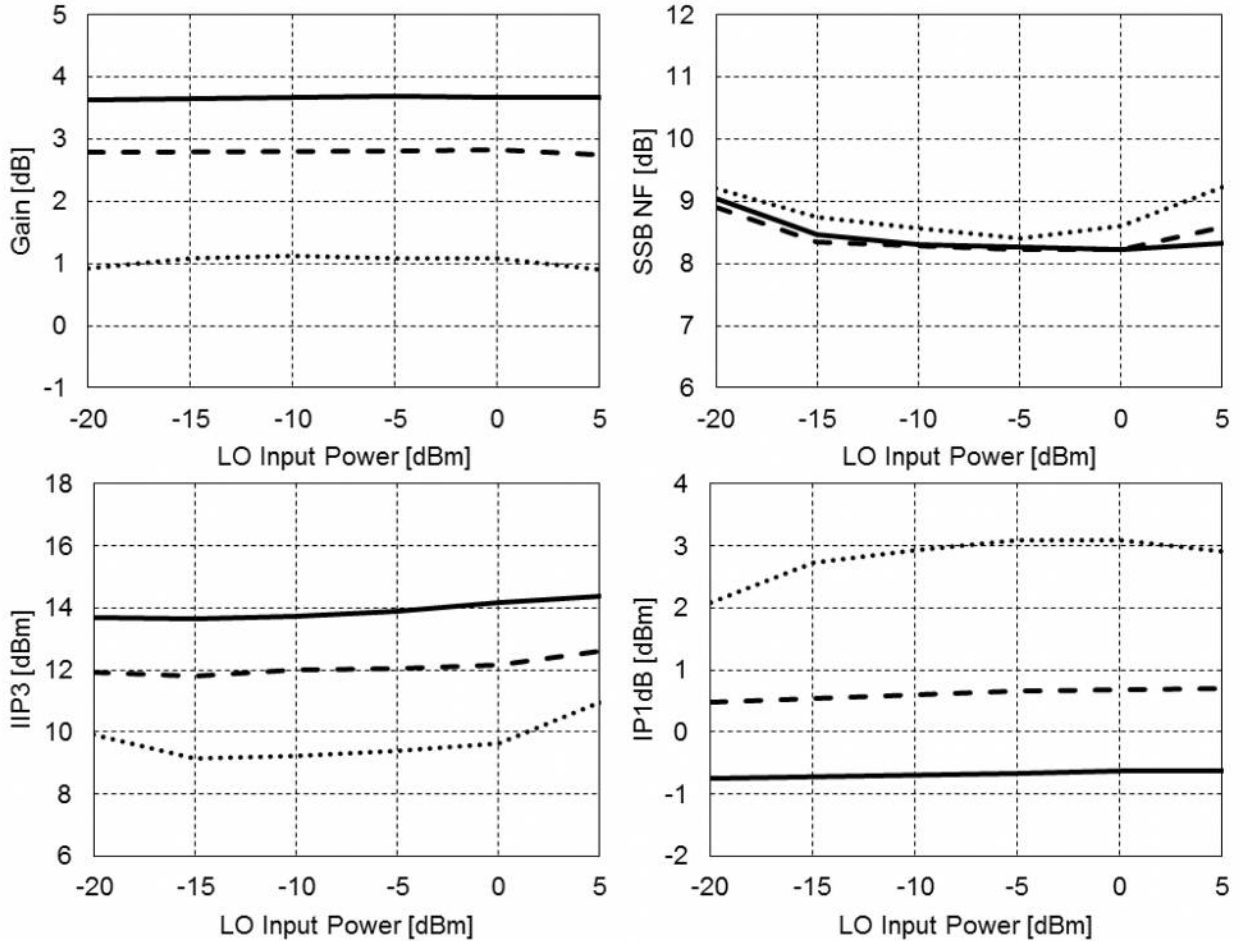

Resistance for current adjustment

- 39kΩ (≅10.5mA)
- - - - - 56kΩ (≅7.5mA)
- 100kΩ (≅4.5mA)

Signal Input = 2000MHz, Signal Output = 50MHz, LO Input = 1950MHz, Output Load Resistor (Rload) = 2.2kΩ, Vdd = 3V, Ta = 25°C.

For high signal input frequency usage, it is recommended to increase the current consumption and reduce the LO input level.

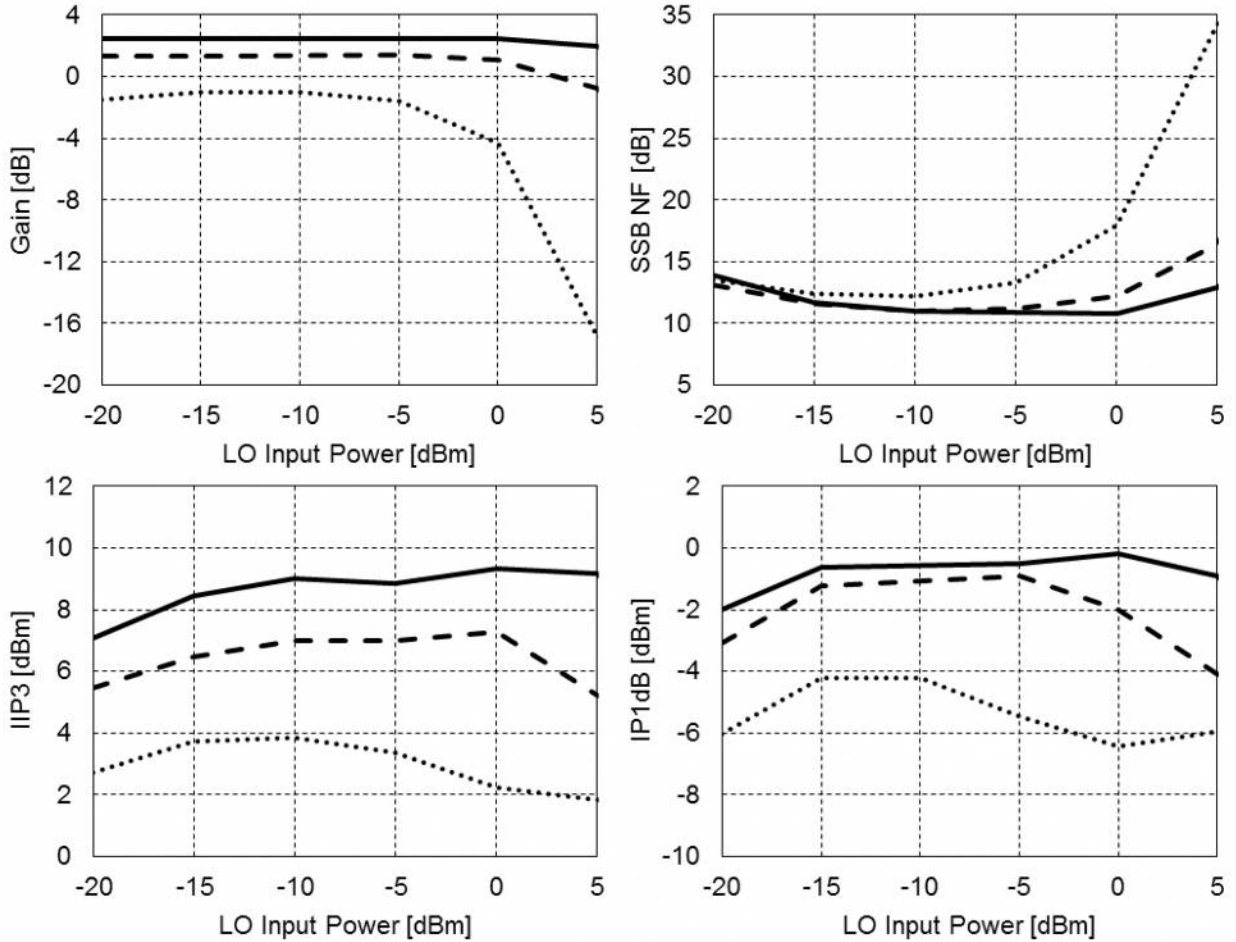

Resistance for current adjustment

- 39kΩ (≅10.5mA)
- - - - - 56kΩ (≅7.5mA)
- 100kΩ (≅4.5mA)

5. Signal input frequency vs. Gain, NF, IIP3, IP1dB

Signal Input > 600MHz : LO Input frequency < Signal Input frequency (Lower LO)

Signal Input ≤ 600MHz : LO Input frequency > Signal Input frequency (Upper LO)

Signal Output = 50MHz, Output Load Resistor (Rload) = 2.2kΩ, Vdd = 3V, Ta = 25°C, LO Input Level = 0dBm.

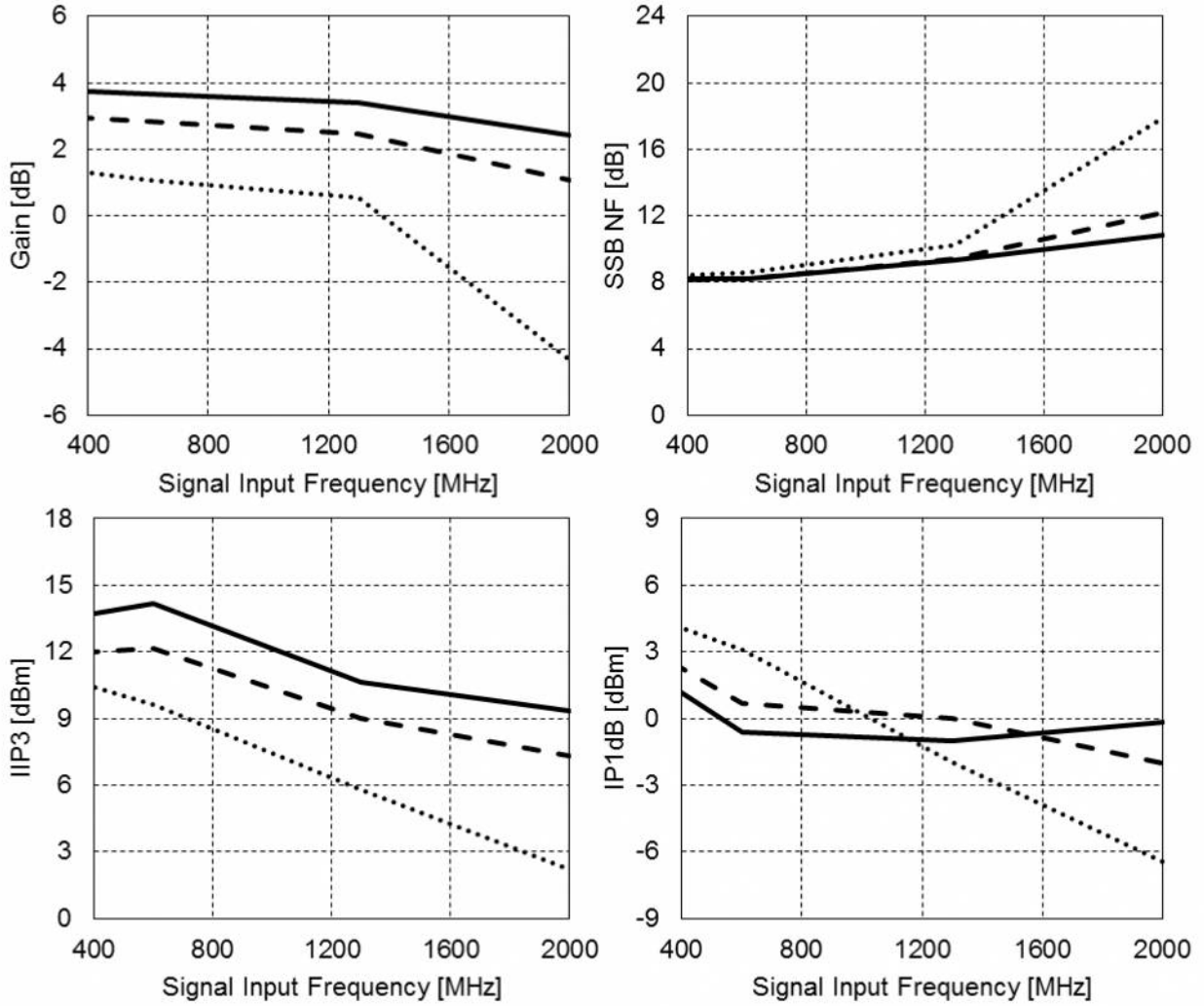

Resistance for current adjustment

- 39kΩ (≅10.5mA)
- - - 56kΩ (≅7.5mA)
- 100kΩ (≅4.5mA)

6. Signal output frequency vs. Gain, NF, IIP3, IP1dB

Signal Output ≤ 150MHz : LO Input frequency < Signal Input frequency (Lower LO)

Signal Output > 150MHz : LO Input frequency > Signal Input frequency (Upper LO)

Signal Input = 600MHz, Output Load Resistor (Rload) = 2.2kΩ, Vdd = 3V, Ta = 25°C, LO Input Level = 0dBm.

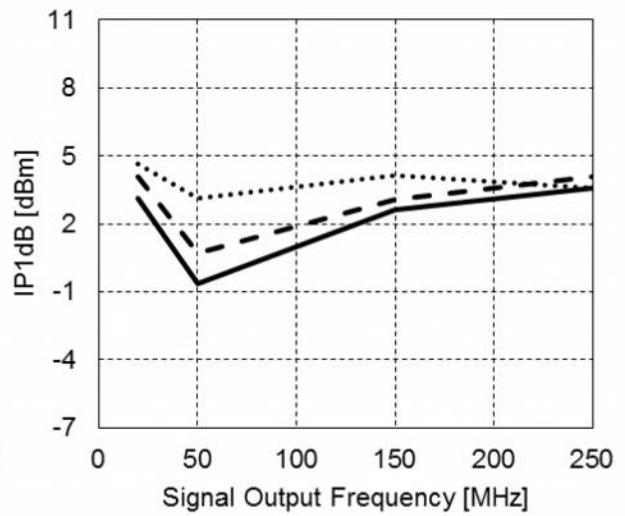
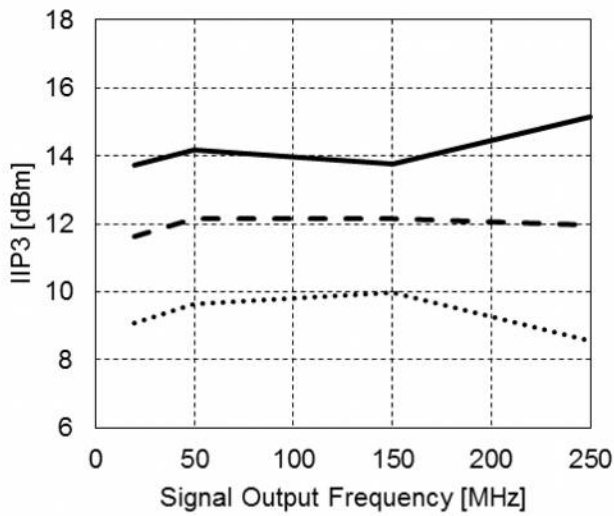
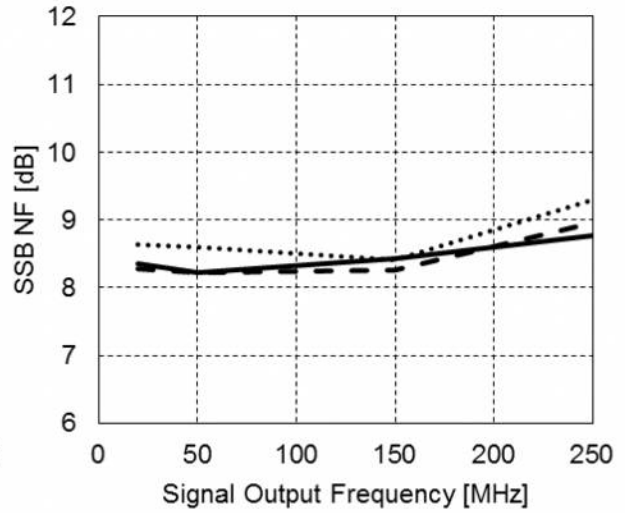
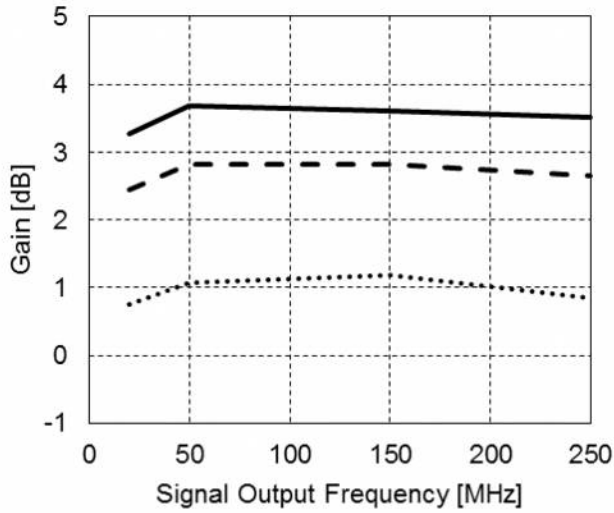

Resistance for current adjustment

- 39kΩ (≅10.5mA)
- - - 56kΩ (≅7.5mA)
- 100kΩ (≅4.5mA)

Signal Input = 140MHz, LO Input frequency < Signal Output frequency (Lower LO), Output Load Resistor (Rload) = 2.2kΩ, Vdd = 3V, Ta = 25°C, LO Input Level = 0dBm.

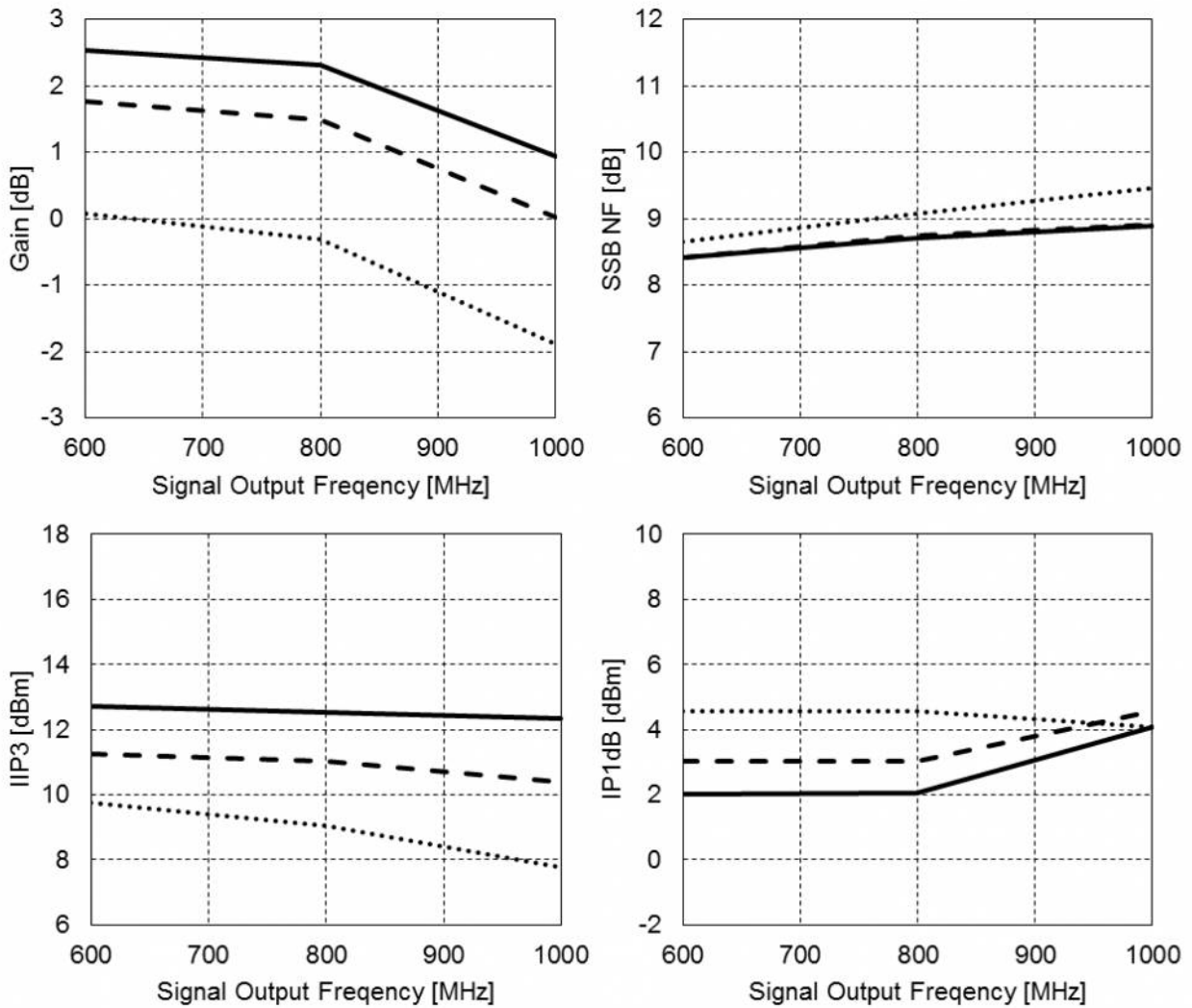

Resistance for current adjustment

- 39kΩ (≅10.5mA)
- - - 56kΩ (≅7.5mA)
- 100kΩ (≅4.5mA)

7. Output Load Resistor (Rload) vs. Gain, NF, IIP3, IP1dB

Signal output ports are differential open drain outputs. Gain can be optimized by the resistance connected to the OUTP and OUTN Pins (Rload). Signal Input = 600MHz, Signal Output = 50MHz, LO Input = 550MHz, Vdd = 3V, Ta = 25°C, LO Input Level = 0dBm.

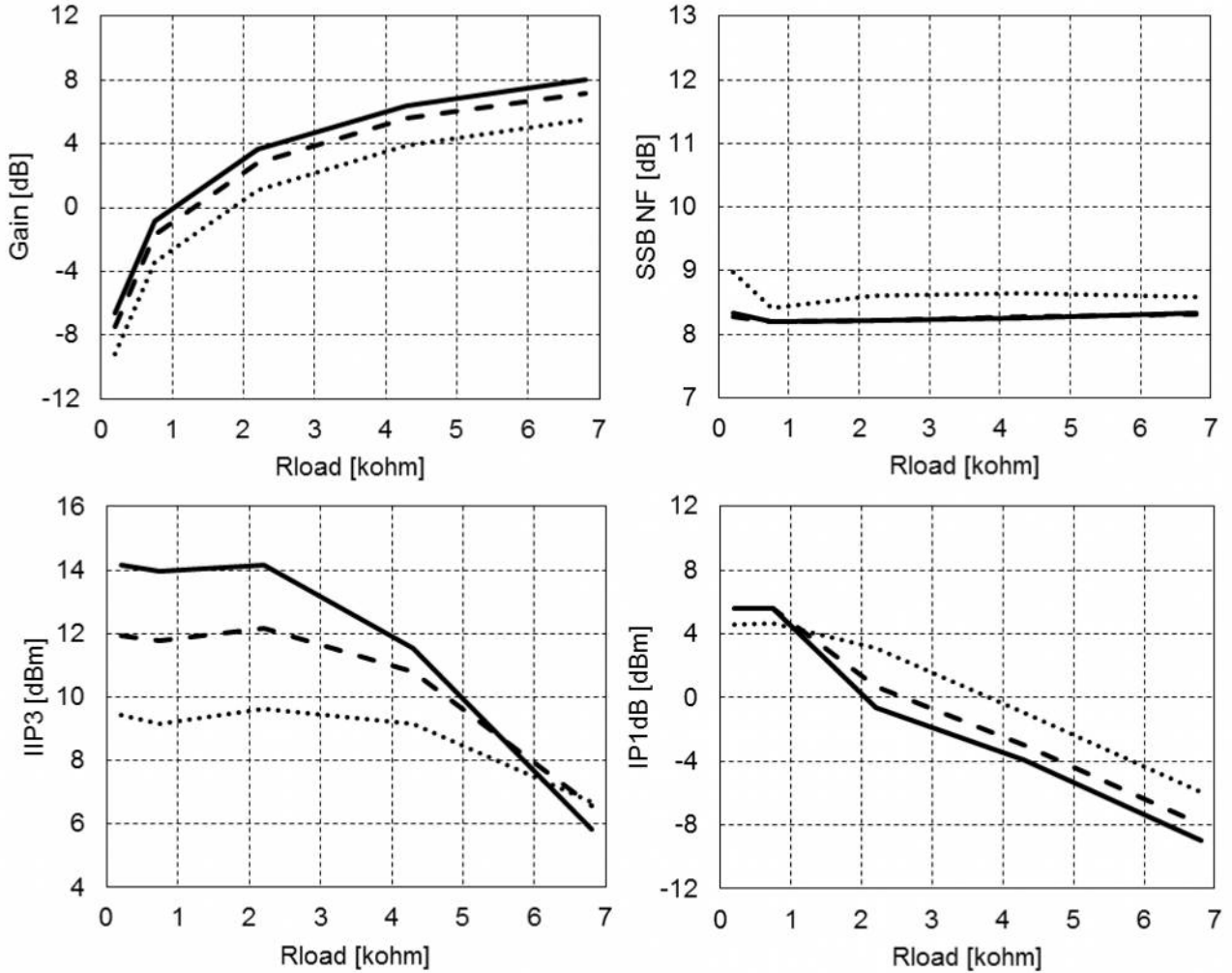

Resistance for current adjustment

- 39kΩ (≈10.5mA)
- - - - - 56kΩ (≈7.5mA)
- 100kΩ (≈4.5mA)

8. Half IF, 1/3 IF

IF Signal Output = 50MHz, LO Input = 550MHz, Output Load Resistor (Rload) = 2.2kΩ, Vdd = 3V, Ta = 25°C, LO Input Level = 0dBm, Current Adjustment Resistor (Rbias) = 39kΩ.

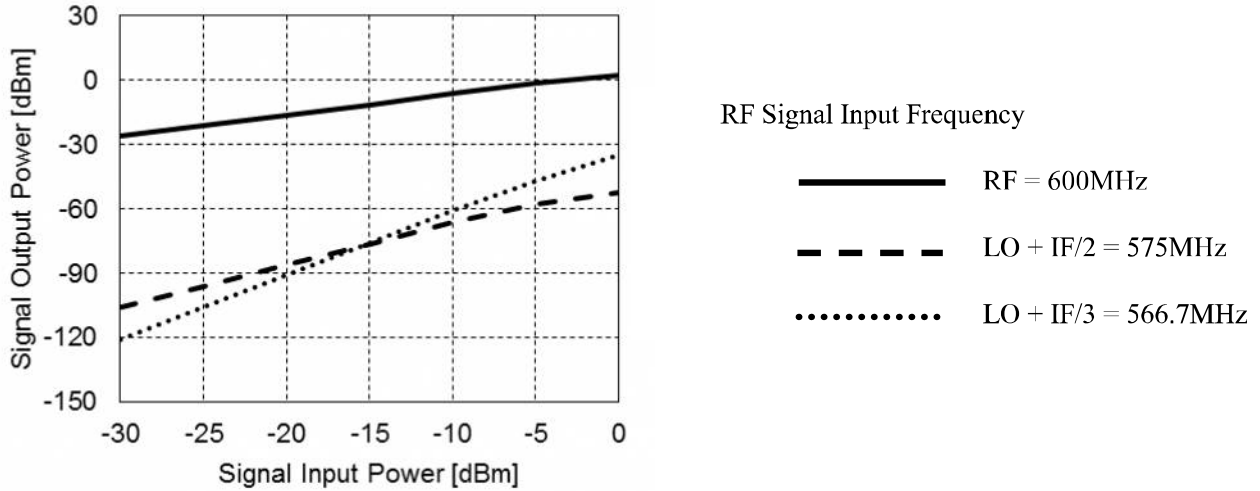

IF Signal Output = 50MHz, LO Input = 1950MHz, Output Load Resistor (Rload) = 2.2kΩ, Vdd = 3V, Ta = 25°C, LO Input Level = 0dBm, Current Adjustment Resistor (Rbias) = 39kΩ.

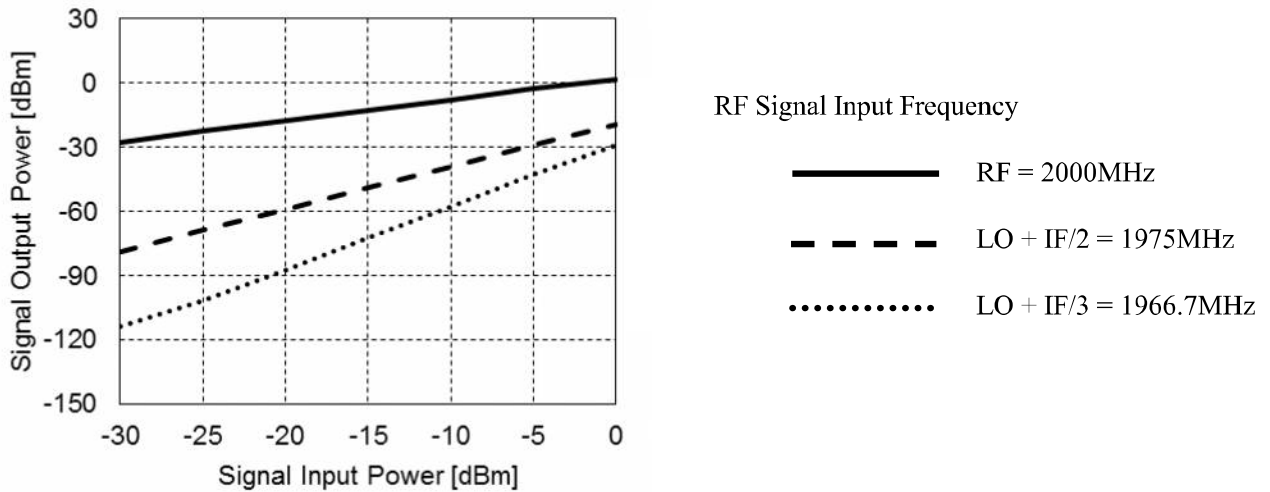

9. Leakage

Signal Output = 50MHz, LO Input frequency < Signal Input frequency (Lower LO), Signal Input Level = -20dBm, Output Load Resistor (Rload) = 2.2kΩ, Vdd = 3V, Ta = 25°C, LO Input Level = 0dBm, Current Adjustment Resistor (Rbias) = 39kΩ.

Table 7. Leakage

Parameter	Signal Input Frequency	Typ. [dBc]
IN – LO Leakage	600MHz	-54
	2000MHz	-54
IN – OUT Leakage	600MHz	-48
	2000MHz	-48
LO – IN Leakage	600MHz	-47
	2000MHz	-40
LO – OUT Leakage	600MHz	-57
	2000MHz	-71

11. Typical Evaluation Board Schematic

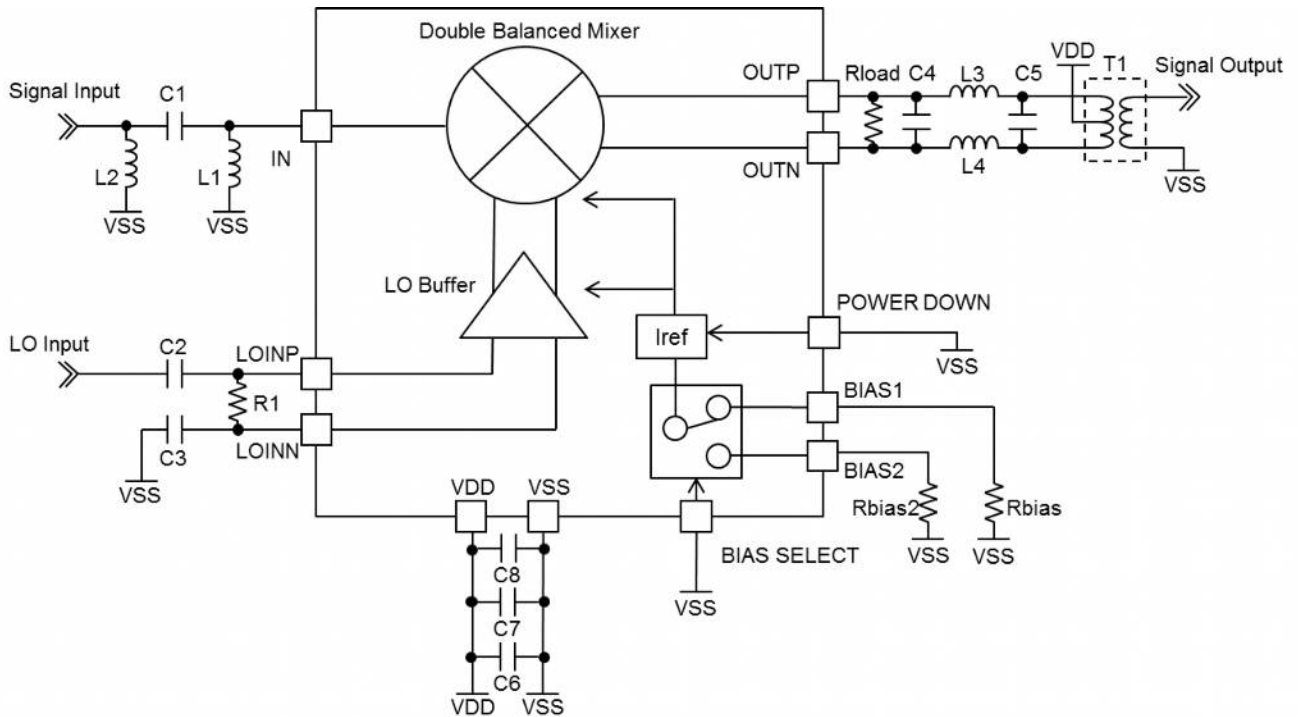

Figure 3. Typical Evaluation Board Schematic

Table 8. Typical Evaluation Board Component Values for Downconversion Applications
(Signal Input = 600MHz, Signal Output = 50MHz)

Ref.	Value	Size	Part Number	Ref.	Value	Size	Part Number
T1	4:1		Mini-Circuits ADT4-6T	C1	8.2pF	1005	Murata GRM1552C1H8R2DZ01
R1	51Ω	1005	KOA RK73K1ETP510	C2	10nF	1005	Murata GRM155B31H103KA88
Rload	2.2kΩ	1005	KOA RK73K1ETP222	C3	10nF	1005	Murata GRM155B31H103KA88
Rbias	39kΩ	1005	KOA RK73K1ETP393	C4	3.3pF	1005	Murata GRM1553C1H3R3CZ01
Rbias2	100kΩ	1005	KOA RK73K1ETP104	C5	-	-	Not Mounted
L1	15nH	1005	Murata LQG15HS15NJ02	C6	10uF	1608	Murata GRM188R60J106ME47
L2	-	-	Not Mounted	C7	10nF	1005	Murata GRM155B31H103KA88
L3	1000nH	2012	Murata LQW21HN1R2J00	C8	100pF	1005	Murata GRM1552C1H101JA01
L4	1000nH	2012	Murata LQW21HN1R2J00				

Table 9. Typical Evaluation Board Component Values for Upconversion Applications
(Signal Input = 50MHz, Signal Output = 450MHz)

Ref.	Value	Size	Part Number	Ref.	Value	Size	Part Number
T1	4:1		Mini-Circuits JTX4-10T	C1	120pF	1005	Murata GRM1552C1H121JA01
R1	51Ω	1005	KOA RK73K1ETP510	C2	10nF	1005	Murata GRM155B31H103KA88
Rload	2.2kΩ	1005	KOA RK73K1ETP222	C3	10nF	1005	Murata GRM155B31H103KA88
Rbias	39kΩ	1005	KOA RK73K1ETP393	C4	-	-	Not Mounted
Rbias2	100kΩ	1005	KOA RK73K1ETP104	C5	2.7pF	1005	Murata GRM1553C1H2R7CZ01
L1	270nH	1005	Murata LQG15HSR27J02	C6	10uF	1608	Murata GRM188R60J106ME47
L2	-	-	Not Mounted	C7	10nF	1005	Murata GRM155B31H103KA88
L3	68nH	1608	Murata LQW18AN68NG00	C8	100pF	1005	Murata GRM1552C1H101JA01
L4	68nH	1608	Murata LQW18AN68NG00				

12. LSI Interface Schematic

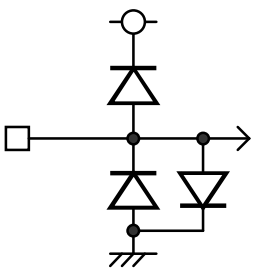
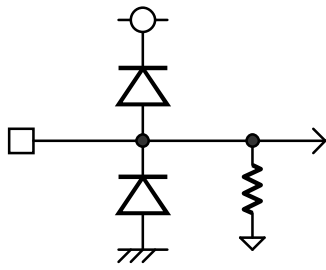
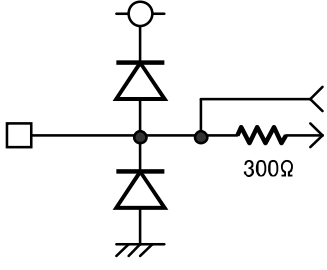
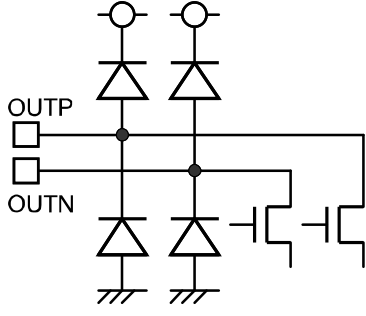
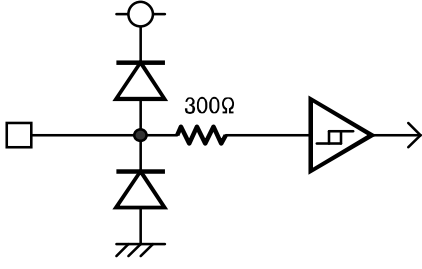
No.	Name	I/O	Function
1	IN	I	Signal Input pin 
4	LOINN	I	LO Input pins 
5	LOINP		
6	BIAS1	I/O	Analog I/O pins 
7	BIAS2		
11	OUTN	O	Signal Output pins 
12	OUTP		
14	POWER DOWN	I	Digital Input pins 
15	BIAS SELECT		

13. Application Information

•Impedance matching network for Signal Input pin

Signal Input port with impedance matching network (highpass filter) is shown in Figure 4. Typical evaluation board component values in 50Ω interface are shown in Table 10.

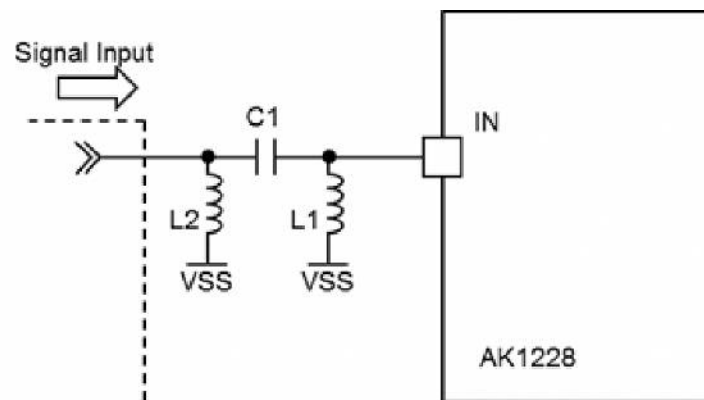

Figure 4. Signal Input port with impedance matching network

Table 10. Signal Input port with impedance matching network

Signal Input Frequency [MHz]	C1 [pF]	L1 [nH]	L2 [nH]
10	470	1500	-
160	27	82	-
300	15	47	-
400	10	22	-
600	8.2	15	-
800	5.6	9.1	-
1300	8.2	5.6	-
1500	5.6	3.3	-
2000	3.3	18	2.2

•Impedance matching network for LO Input pin

LOIN port can be matched with resistive impedance matching network in $10\text{MHz} < \text{LO Input} < 2000\text{MHz}$. Typical evaluation board component values in 50Ω interface is shown in Figure 5.

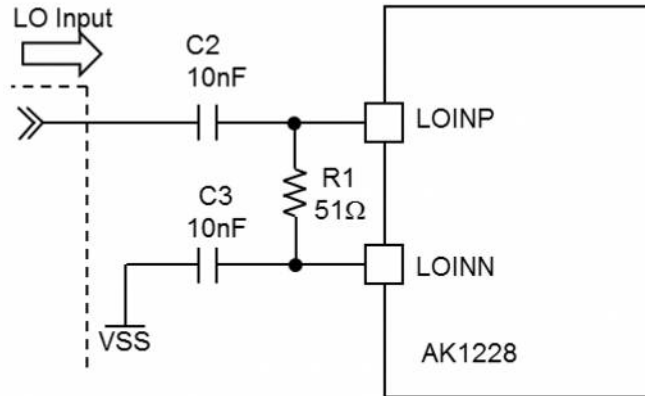

Figure 5. LO input port with impedance matching network

•Impedance matching network for Signal Output pin

Signal output port with impedance matching network (lowpass filter and balun) is shown in Figure 6. OUTP and OUTN pins need power feeding via center tap of balun. Typical evaluation board component values in 50Ω interface are shown in Table 11.

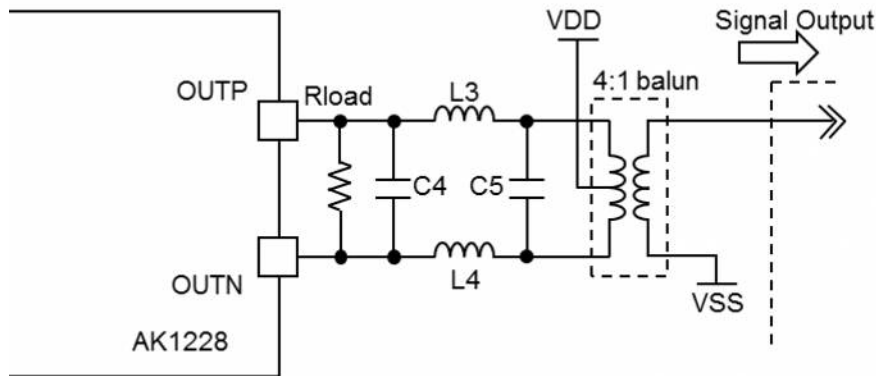

Figure 6. Signal output port with impedance matching network

Table 11. Signal output port with impedance matching network

Signal Output Frequency [MHz]	Rload [kΩ]	L3/L4 [nH]	C4 [pF]	C5 [pF]
11	2.2	4700	18	-
20	2.2	2200	10	-
50	2.2	1000	3.3	-
70	2.2	680	2.2	-
100	2.2	470	1.2	-
150	2.2	330	0.4	-
250	2.2	180	-	0.5
800	2.2	22	-	2.2

•Impedance matching network with LC

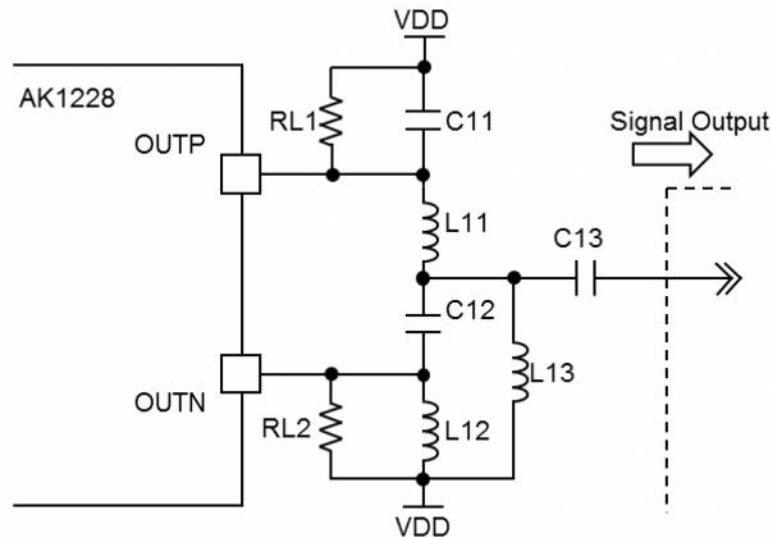

Figure 7. Impedance matching network with LC

Impedance matching network with LC is shown in Figure 7. AK1228 has open drain outputs, so $RL1 + RL2$ is output load resistance. C11 and L11 compose lowpass filter. C12 and L12 are for highpass filter. C13 is DC blocking capacitor and L13 is RF choke. OUTP and OUTN pins need power feeding via L11, L12 and L13.

The differential voltage from OUTP/N can be converted to a single-ended by L11, L12, C11 and C12 properly.

The differential impedance ($RL1 + RL2$) is converted to single-ended output terminating impedance R_o .

L11, C11, L12 and C12 are calculated as below. f_{out} is signal output frequency.

$$C_{11} = C_{12} = \frac{1}{2\pi * f_{OUT} * \sqrt{(R_{L1} + R_{L2}) * R_o}}$$

$$L_{11} = L_{12} = \frac{\sqrt{(R_{L1} + R_{L2}) * R_o}}{2\pi * f_{OUT}}$$

For example, in the case of Signal Output = 50MHz, Output Load Resistor (R_{load}) = 2.2k Ω in 50 Ω interface, L11, C11, L12 and C12 are calculated as below.

$$C_{11} = C_{12} = \frac{1}{2\pi * (50 * 10^6) * \sqrt{(2.2 * 10^3) * 50}} = 9.6\text{pF}$$

$$L_{11} = L_{12} = \frac{\sqrt{(2.2 * 10^3) * 50}}{2\pi * (50 * 10^6)} = 1056\text{nH}$$

L13 and C13 should be large enough not to affect the impedance at signal output frequency. In some cases the impedance matching can be optimized by L13 and C13.

For example, in the case of Signal Output = 50MHz, Output Load Resistor (Rload) = 2.2k Ω in 50 Ω interface, it is recommended to choose 2200nH and 1000pF as L13 and C13. If any correction is needed, it can be adjusted by reducing the value of L13 and C13.

These calculated values are approximation. In some cases, some correction is needed due to the effect of parasitic capacitance of external parts or/and PCBs. The impedance matching network components should be decided through enough evaluation on AK1228.

Typical Performance using impedance matching network with LC is below. Signal Input = 600MHz, Signal Output = 50MHz, LO Input = 550MHz, Output Load Resistor (Rload) = 2.2k Ω , Vdd = 3V, Ta = 25 $^{\circ}$ C, LO Input Level = 0dBm,

Table 12. Typical Component Values using impedance matching with LC

Ref.	Value	Size	Part Number
RL1, RL2	1.1k Ω	1005	KOA RK73K1ETP112
L11, L12	1000nH	2012	Murata LQW21HN1R0J00
C11, C12	10pF	1005	Murata GRM1552C1H100JA01
L13	2200nH	2012	Murata LQW21HN2R2J00
C13	150pF	1005	Murata GRM1552C1H151JA01

Table 13. Typical Performance using impedance matching with LC

Parameter	Rbias	Min. Typ. Max.	Unit
Conversion Gain	Rbias = 39k Ω (\cong 10.5mA)	3.6	dB
	Rbias = 100k Ω (\cong 4.5mA)	1.3	
SSB Noise Figure (NF)	Rbias = 39k Ω (\cong 10.5mA)	8.6	dB
	Rbias = 100k Ω (\cong 4.5mA)	8.5	
IP1dB	Rbias = 39k Ω (\cong 10.5mA)	2.1	dBm
	Rbias = 100k Ω (\cong 4.5mA)	3.6	
IIP3	Rbias = 39k Ω (\cong 10.5mA)	15.5	dBm
	Rbias = 100k Ω (\cong 4.5mA)	9.6	

The phase and amplitude balance is achieved at IF Output frequency by using impedance matching network with LC. The port-to-port leakage is improved with the phase and amplitude balance is achieved at RF, LO, and IF frequency with wide band balun.

•Output Load Resistor and Gain

Signal output ports are differential open drain outputs. Gain can be optimized by the resistance connected to the OUTP and OUTN Pins (Rload). Signal Input = 600±10MHz, Signal Output = 50±10MHz, LO Input = 550MHz, Vdd = 3V, Ta = 25°C, LO Input Level = 0dBm, Current Adjustment Resistor (Rbias) = 39kΩ. Test circuit is shown in Figure 3.

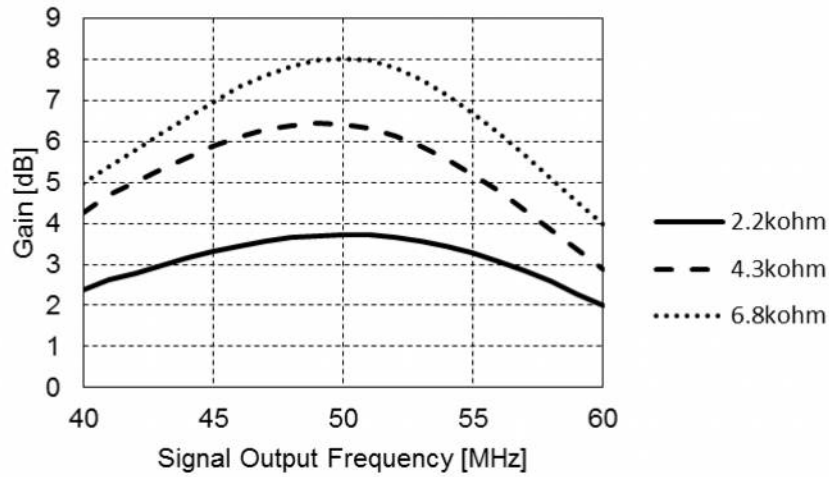

•The Improvement of Analog circuit characteristics with a differential LO input

AK1228 is a high linearity and low noise mixer that can be driven by a single ended LO. However it is possible to further improve the analog characteristics with a differential LO input. Gain, NF, Half1F is improved by reducing the second-order distortion in exchange for the chip components increases four points. Test circuit is shown in Figure 8.

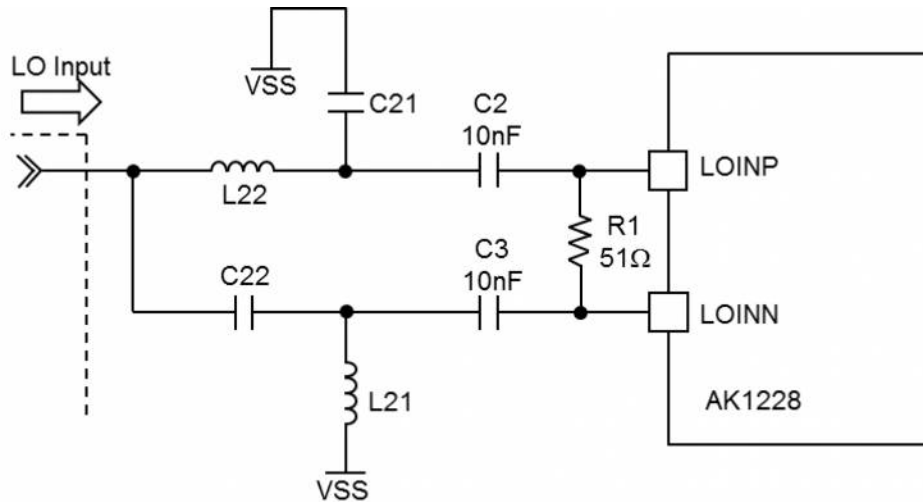

Figure 8. Example of Impedance matching network with a differential LO input

C21 and L22 compose lowpass filter. C22 and L21 are for highpass filter. C2, C3 is DC blocking capacitor. The impedance of LOINP/N is high impedance so R1 is differential input resistance.

The single-ended LO input voltage can be converted to differential voltage of LOINP/N by L21, C21, L22 and C22 properly. The output resistance R_o of the previous stage is converted to a differential input resistance R1.

L21, C21, L22 and C22 are calculated as below. f_{LO} is LO input frequency.

$$C_{21} = C_{22} = \frac{1}{2\pi * f_{LO} * \sqrt{R_1 * R_{IN}}}$$

$$L_{21} = L_{22} = \frac{\sqrt{R_1 * R_{IN}}}{2\pi * f_{LO}}$$

For example, in the case of LO signal input = 1250MHz, differential input resistance $R_1 = 51\Omega$ in 50Ω interface, L21, C21, L22 and C22 are calculated as below.

$$C_{21} = C_{22} = \frac{1}{2\pi * (1250 * 10^6) * \sqrt{51 * 50}} = 2.5\text{pF}$$

$$L_{21} = L_{22} = \frac{\sqrt{51 * 50}}{2\pi * (1250 * 10^6)} = 6.4\text{nH}$$

C2, C3 should be large enough not to affect the differential input impedance R1 at LO input frequency.

These calculated values are approximation. In some cases, some correction is needed due to the effect of parasitic capacitance of external parts or/and PCBs. The impedance matching network components should be decided through enough evaluation on AK1228.

Typical Performance using impedance matching network with a differential LO input is below. Signal Input = 1300MHz, Signal Output = 50MHz, LO Input = 1250MHz, Output Load Resistor (Rload) = 2.2kΩ, Vdd = 3V, Ta = 25°C, LO Input Level = 0dBm.

Table 14. Typical Component Values using impedance matching with a differential LO input

Ref.	Value	Size	Part Number
R1	51Ω	1005	KOA RK73K1ETP510
C2, C3	10nF	1005	Murata GRM155B31H103KA88
L21, L22	6.2nH	1005	Murata LQW15AN6N2C00
C21, C22	2.4pF	1005	Murata GJM1553C1H2R4CB01

Gain/NF performance

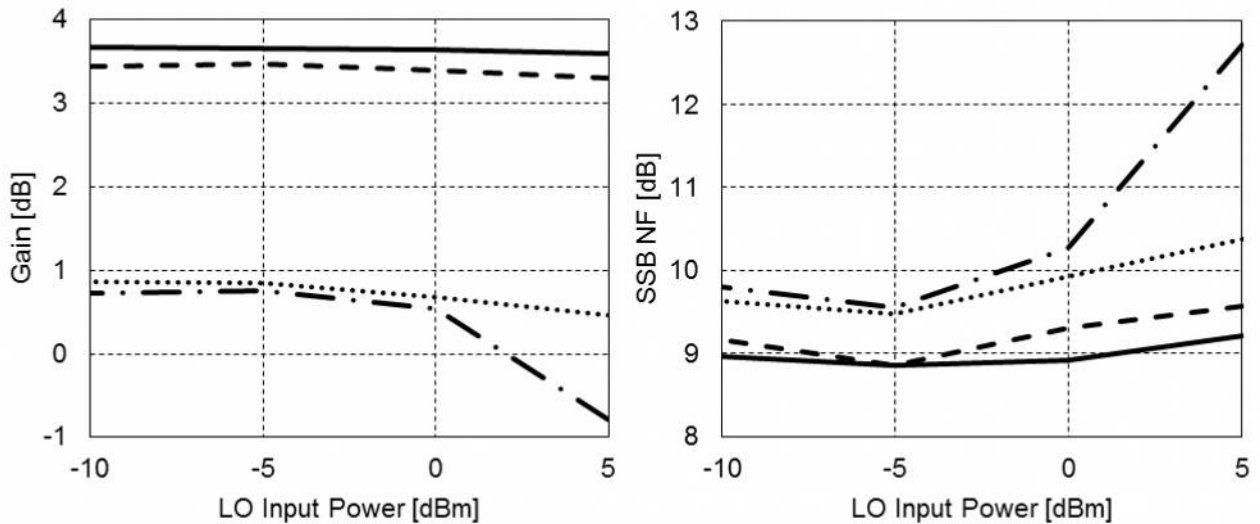

HalfIF performance (Signal input Frequency = LO + IF/2 = 1275MHz)

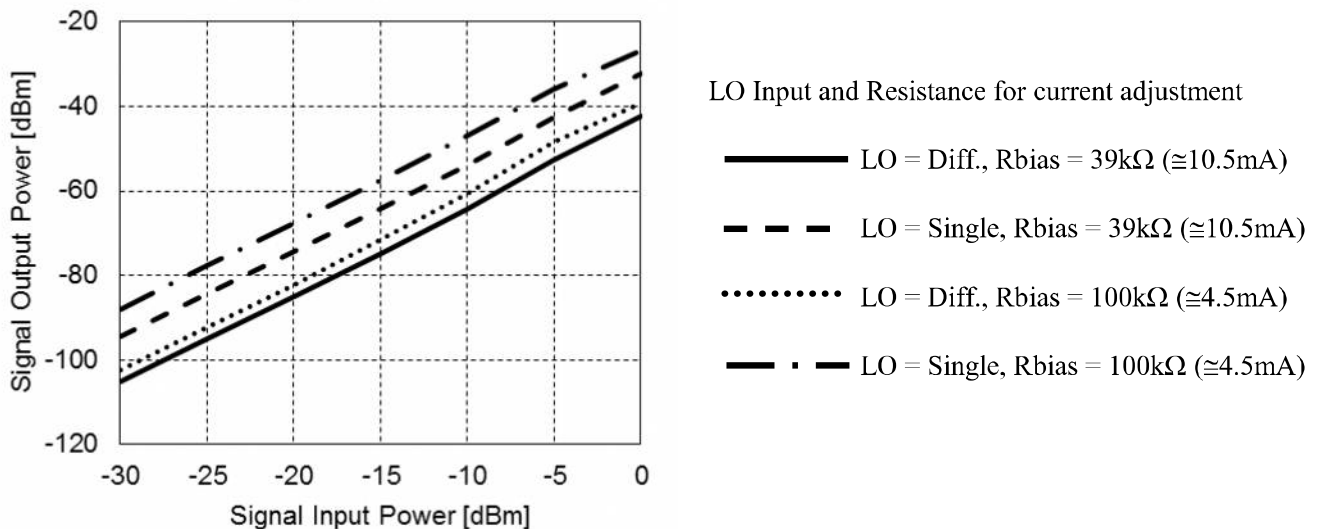

•Evaluation Board

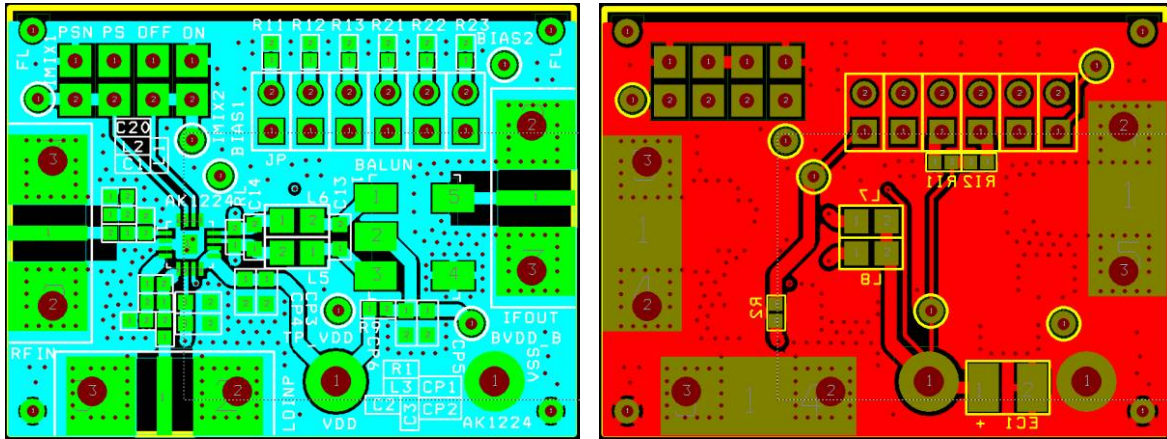

Figure 9. AK1224/AK1228 Evaluation Board (Balun)

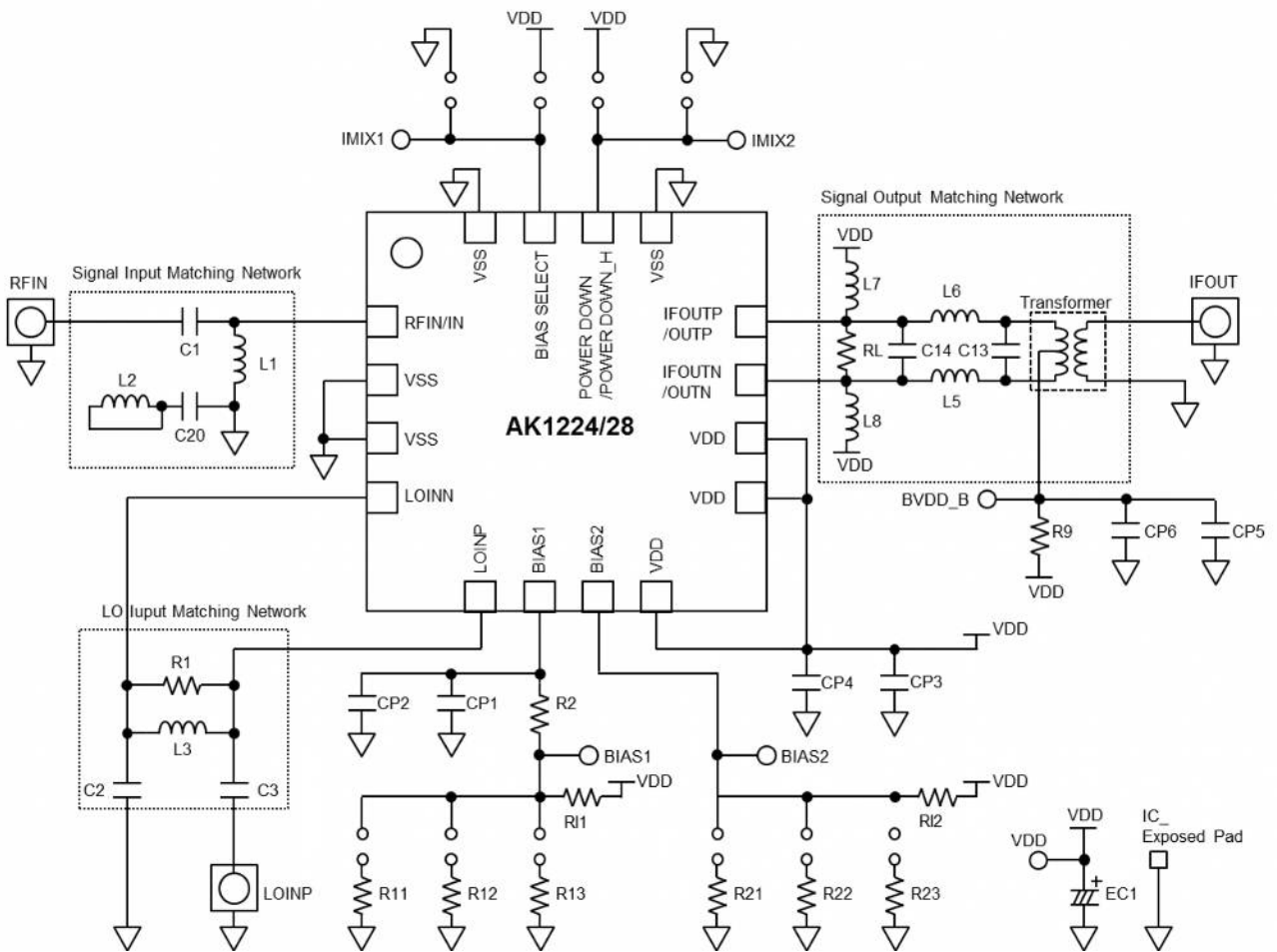

Figure 10. AK1224/AK1228 Evaluation Board Schematic (Balun)

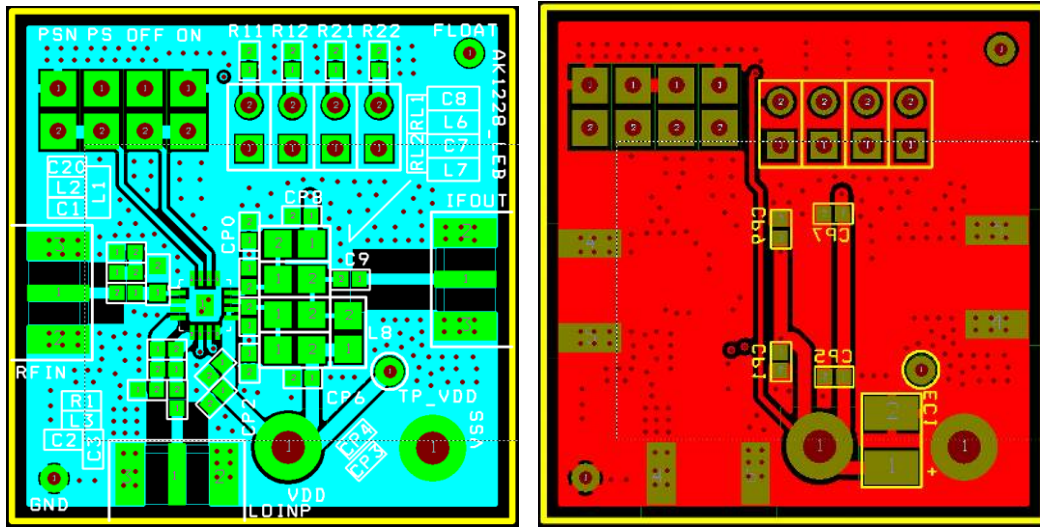

Figure 11. AK1224/AK1228 Evaluation Board (matching network with LC)

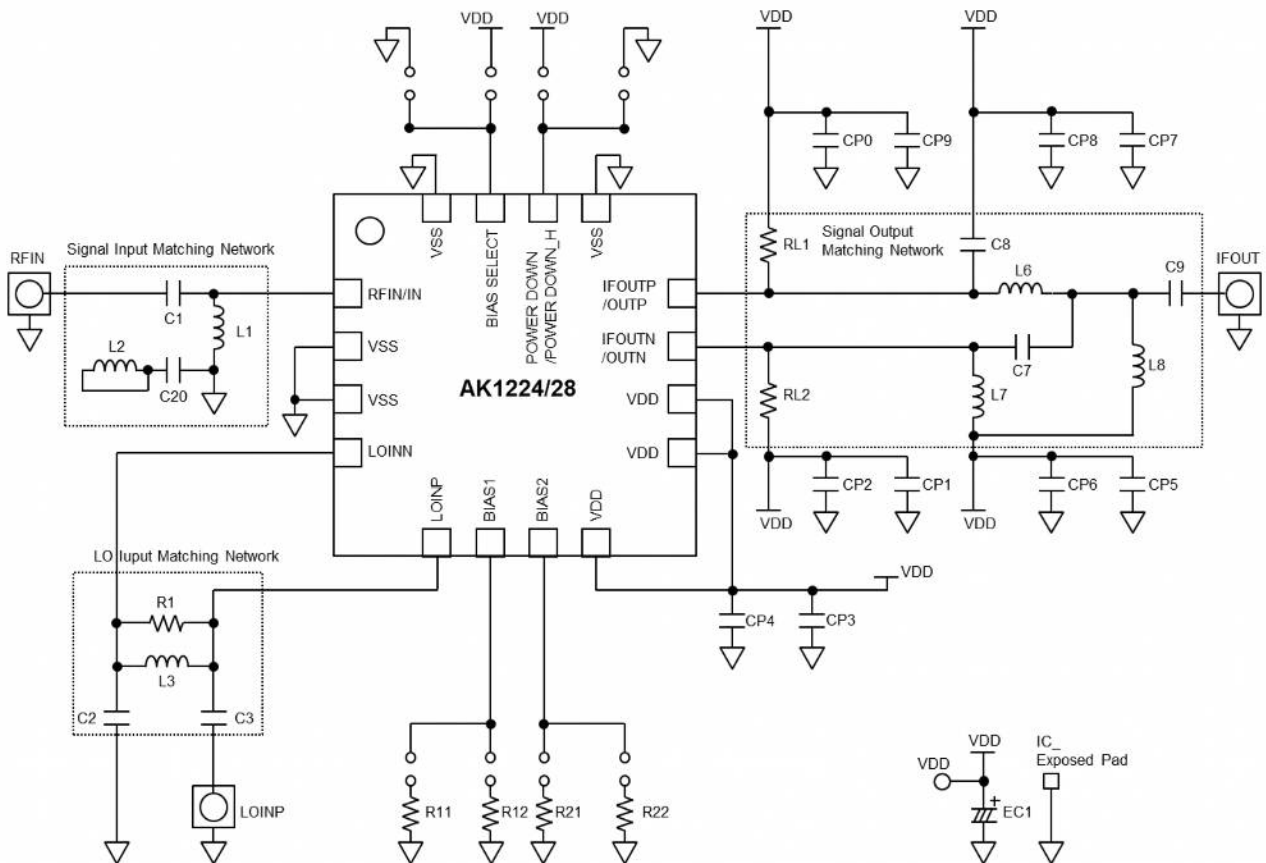

Figure 12. AK1224/AK1228 Evaluation Board Schematic (matching network with LC)

14. Outer Dimensions

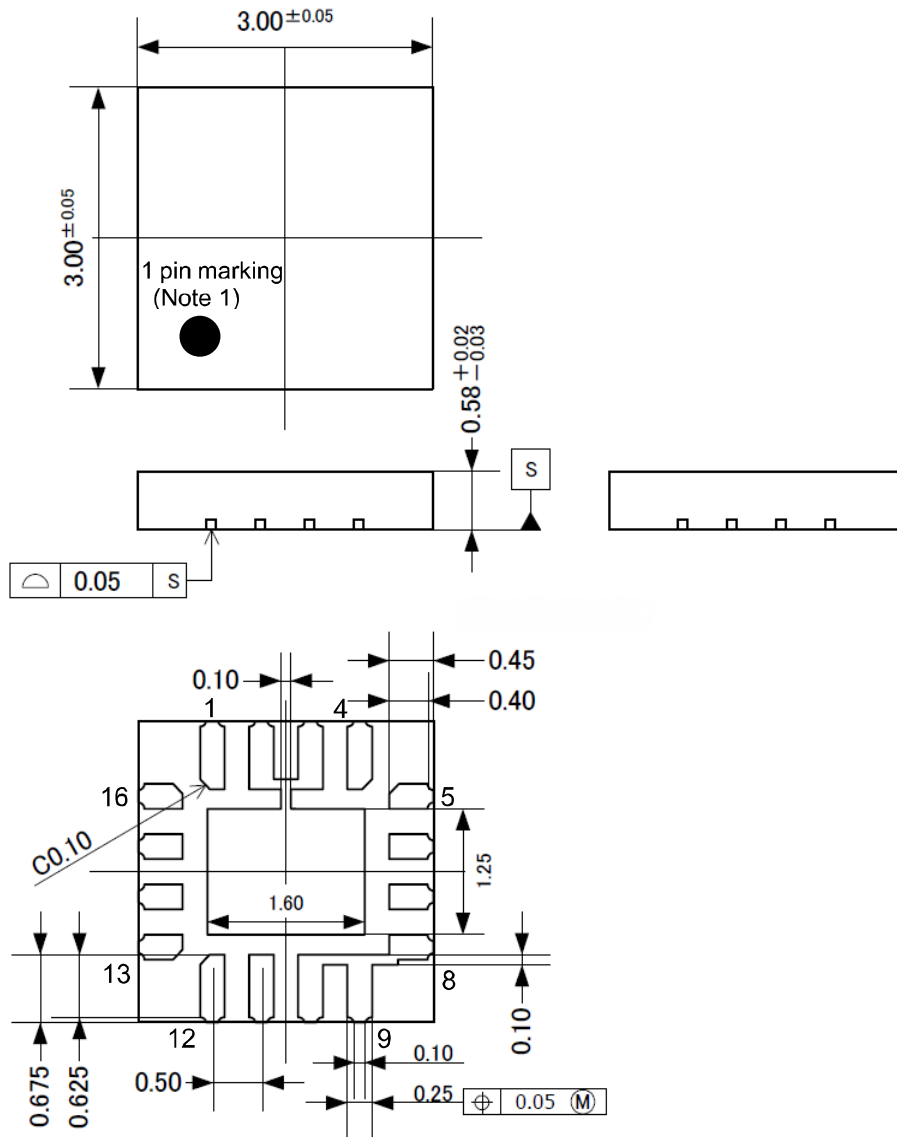

Figure 13. Outer Dimensions

Note 1. 1 pin marking is only a reference for the 1 pin location on the top of package.

15. Marking

- (a) Style : UQFN
(b) Number of Pins : 16
(c) 1 pin marking : ○
(d) Product number : 1228
(e) Date code : YWWL (4 digits)
Y : Lower 1 digit of calendar year (Year 2013 → 3, 2014 → 4 ...)
WW : Week
L : Lot identification, given to each product lot which is made in a week
→ LOT ID is given in alphabetical order (A, B, C, ...)

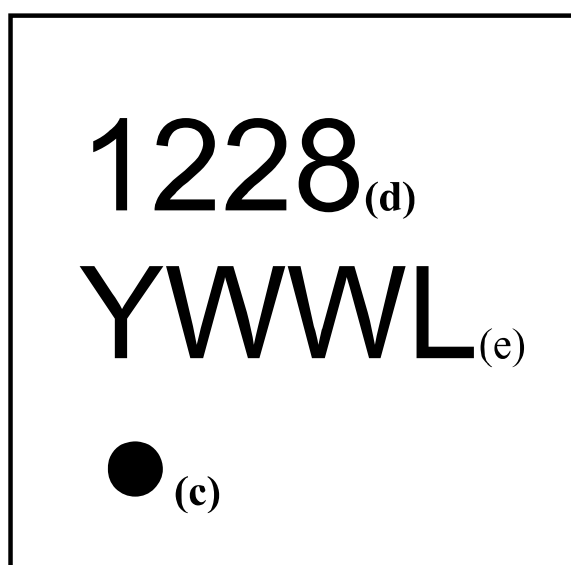

Figure 14. Marking

IMPORTANT NOTICE

0. Asahi Kasei Microdevices Corporation (“AKM”) reserves the right to make changes to the information contained in this document without notice. When you consider any use or application of AKM product stipulated in this document (“Product”), please make inquiries the sales office of AKM or authorized distributors as to current status of the Products.
1. All information included in this document are provided only to illustrate the operation and application examples of AKM Products. AKM neither makes warranties or representations with respect to the accuracy or completeness of the information contained in this document nor grants any license to any intellectual property rights or any other rights of AKM or any third party with respect to the information in this document. You are fully responsible for use of such information contained in this document in your product design or applications. **AKM ASSUMES NO LIABILITY FOR ANY LOSSES INCURRED BY YOU OR THIRD PARTIES ARISING FROM THE USE OF SUCH INFORMATION IN YOUR PRODUCT DESIGN OR APPLICATIONS.**
2. The Product is neither intended nor warranted for use in equipment or systems that require extraordinarily high levels of quality and/or reliability and/or a malfunction or failure of which may cause loss of human life, bodily injury, serious property damage or serious public impact, including but not limited to, equipment used in nuclear facilities, equipment used in the aerospace industry, medical equipment, equipment used for automobiles, trains, ships and other transportation, traffic signaling equipment, equipment used to control combustions or explosions, safety devices, elevators and escalators, devices related to electric power, and equipment used in finance-related fields. Do not use Product for the above use unless specifically agreed by AKM in writing.
3. Though AKM works continually to improve the Product’s quality and reliability, you are responsible for complying with safety standards and for providing adequate designs and safeguards for your hardware, software and systems which minimize risk and avoid situations in which a malfunction or failure of the Product could cause loss of human life, bodily injury or damage to property, including data loss or corruption.
4. Do not use or otherwise make available the Product or related technology or any information contained in this document for any military purposes, including without limitation, for the design, development, use, stockpiling or manufacturing of nuclear, chemical, or biological weapons or missile technology products (mass destruction weapons). When exporting the Products or related technology or any information contained in this document, you should comply with the applicable export control laws and regulations and follow the procedures required by such laws and regulations. The Products and related technology may not be used for or incorporated into any products or systems whose manufacture, use, or sale is prohibited under any applicable domestic or foreign laws or regulations.
5. Please contact AKM sales representative for details as to environmental matters such as the RoHS compatibility of the Product. Please use the Product in compliance with all applicable laws and regulations that regulate the inclusion or use of controlled substances, including without limitation, the EU RoHS Directive. AKM assumes no liability for damages or losses occurring as a result of noncompliance with applicable laws and regulations.
6. Resale of the Product with provisions different from the statement and/or technical features set forth in this document shall immediately void any warranty granted by AKM for the Product and shall not create or extend in any manner whatsoever, any liability of AKM.
7. This document may not be reproduced or duplicated, in any form, in whole or in part, without prior written consent of AKM.

●Related Parts

Part#	Description	Comments
Mixer		
AK1220	100MHz~900MHz High Linearity Down Conversion Mixer	IIP3:+22dBm
AK1222	100MHz~900MHz Low Power Down Conversion Mixer	IDD:2.9mA
AK1224	100MHz~900MHz Low Noise, High Linearity Down Conversion Mixer	NF:8.5dB, IIP3:+18dBm
AK1228	10MHz~2GHz Up/Down Conversion Mixer	3V Supply, NF:8.5dB
AK1221	0.7GHz~3.5GHz High Linearity Down Conversion Mixer	IIP3:+25dBm
AK1223	3GHz~8.5GHz High Linearity Down Conversion Mixer	IIP3:+13dB, NF:15dB
PLL Synthesizer		
AK1541	20MHz~600MHz Low Power Fractional-N Synthesizer	IDD:4.6mA
AK1542A	20MHz~600MHz Low Power Integer-N Synthesizer	IDD:2.2mA
AK1543	400MHz~1.3GHz Low Power Fractional-N Synthesizer	IDD:5.1mA
AK1544	400MHz~1.3GHz Low Power Integer-N Synthesizer	IDD:2.8mA
AK1590	60MHz~1GHz Fractional-N Synthesizer	IDD:2.5mA
AK1545	0.5GHz~3.5GHz Integer-N Synthesizer	16-TSSOP
AK1546	0.5GHz~3GHz Low Phase Noise Integer-N Synthesizer	Normalized C/N:-226dBc/Hz
AK1547	0.5GHz~4GHz Integer-N Synthesizer	5V Supply
AK1548	1GHz~8GHz Low Phase Noise Integer-N Synthesizer	Normalized C/N:-226dBc/Hz
IFVGA		
AK1291	100~300MHz Analog Signal Control IF VGA w/ RSSI	Dynamic Range:30dB
integrated VCO		
AK1572	690MHz~4GHz Down Conversion Mixer with Frac.-N PLL and VCO	IIP3:24dBm, -111dBc/Hz@100kHz
AK1575	690MHz~4GHz Up Conversion Mixer with Frac.-N PLL and VCO	IIP3:24dBm, -111dBc/Hz@100kHz
IF Receiver (2nd Mixer + IF BPF + FM Detector)		
AK2364	Built-in programmable AGC+BPF, FM detector IC	IFBPF: ±10kHz ~ ±4.5kHz
AK2365A	Built-in programmable AGC+BPF, IFIC	IFBPF: ±7.5kHz ~ ±2kHz
Analog BB for PMR/LMR		
AK2345C	CTCSS Filter, Encoder, Decoder	24-VSOP
AK2360/ AK2360A	Inverted frequency(3.376kHz/3.020kHz) scrambler	8-SOP
AK2363	MSK Modem/DTMF Receiver	24-QFN
AK2346B	0.3-2.55/3.0kHz Analog audio filter,	24-VSOP
AK2346A	Emphasis, Compressor, scrambler, MSK Modem	24-QFN
AK2347B	0.3-2.55/3.0kHz Analog audio filter	24-VSOP
AK2347A	Emphasis, Compressor, scrambler, CTCSS filter	24-QFN
Function IC		
AK2330	8-bit 8ch Electronic Volume	VREF can be selected for each channel
AK2331	8-bit 4ch Electronic Volume	VREF can be selected for each channel

Asahi Kasei Microdevices Corporation ("AKM") reserves the right to make changes to the information contained in this document without notice. When you consider any use or application of AKM product stipulated in this document, please make inquiries the sales office of AKM or authorized distributors as to current status of the Products.