

DESIGNED & DIMENSIONED  
IN MILLIMETERS[INCHES]

DO NOT  
SCALE FROM  
THIS PRINT

ACRK-22-XX-X-X-XX-P-X

RECEPTACLE KIT  
SIZE

KEY FEATURE  
(SEE NOTE 2, SHT. 4)  
-1: ORANGE  
-2: GREEN  
-3: BLUE  
-4: YELLOW

LEAD STYLE  
-01: 30 POS (1.0 TERM/SKT), 20 - 24 AWG  
-02: 20 POS (1.0 TERM/SKT), 20 - 24 AWG  
-03: 8 POS PWR (1.5 TERM/SKT), 14 - 18 AWG  
\* -04: 6 POS (COAX PLUG/JACK), CCA-316  
-05: 20 POS COMBO  
(4 X 1.5 TERM/SKT, 14 - 18 AWG)  
(16 X 1.0 TERM/SKT, 20 - 24 AWG)  
\* -06: 16 POS COMBO  
(4 X COAX PLUG/JACK, CCA-316)  
(12 X 1.0 TERM/SKT, 20 - 24 AWG)

STYLE  
-P: PLASTIC

TERMINATION  
(SEE SHT. 4)  
-C: SOLDER CUP  
-B1: .062 BOARD MOUNT  
(NOT AVAILABLE WITH  
-04, OR -06 LEADSTYLES.)

GENDER  
-T: TERMINAL  
-S: SOCKET

PLATING  
-G: 10µ" GOLD ON CONTACT  
-H: 30µ" GOLD ON CONTACT

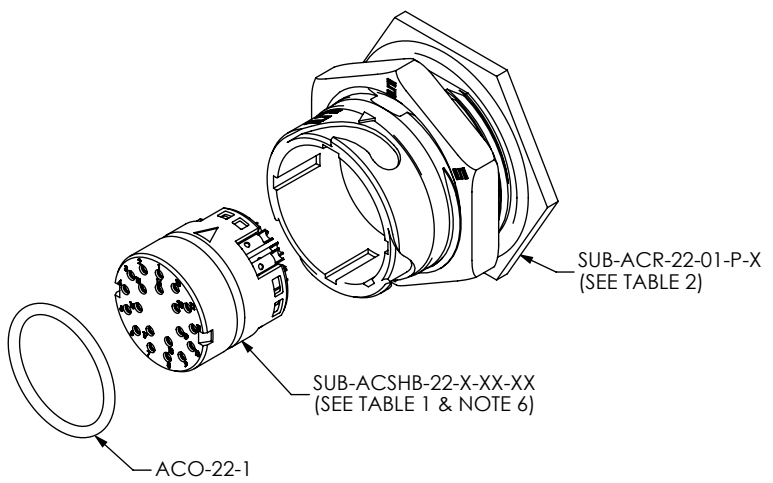

FIG 1  
ACRK-22-02-X-S-X-P-1 SHOWN

\* = NOT RELEASED FOR PRODUCTION

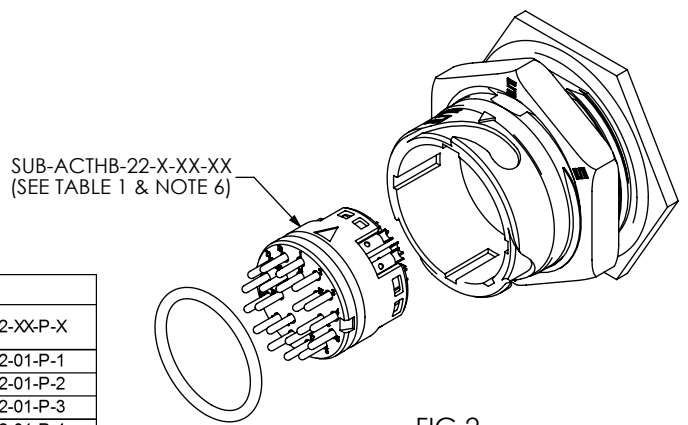

FIG 2  
ACRK-22-02-X-T-X-P-1 SHOWN  
(SAME AS FIG 1, EXCEPT AS SHOWN)

**TABLE 2**

KEY FEATURE	SUB-ACR-22-XX-P-X
-1	SUB-ACR-22-01-P-1
-2	SUB-ACR-22-01-P-2
-3	SUB-ACR-22-01-P-3
-4	SUB-ACR-22-01-P-4

- NOTES:
1. KIT COMPONENTS TO BE PACKAGED IN BAGS PER PACKAGING STANDARD CO-RF-WI-3001-M.
  2. KEY FEATURE DETERMINES COLOR OF COLOR KEY RING AND DUSTCAP LANYARD IF APPLICABLE.
  3. REFER TO DCA-ACR-22-P-X PRINT FOR DUST CAP.
  4. PANEL THICKNESS RANGE: 0.80[.031] - 5.20[.205].
  5. TORQUE SPECIFICATION FOR PANEL NUT: 1.7Nm[15.00 IN-LB] - 2.3Nm[20IN-LB].
  6. RECOMMENDED INSERTION TOOL: CAT-AC-22-M.
  7. NOTE DELETED.

**TABLE 1**

LEAD STYLES	GENDER	TERMINATION					
		-C: SOLDER CUP			-B1: BOARD MOUNT		
		SUB-ASSEMBLY/HOLDER BODY PART #		COAX PLUG/JACK PART #		SUB-ASSEMBLY PART #	
		PLATING		PLATING		PLATING	
		-G	-H	AC-X-C-H-ST-CA1	QTY	-G	-H
-01	-T	SUB-ACTHB-22-G-01	SUB-ACTHB-22-H-01	NA		SUB-ACTHB-22-G-01-B1	SUB-ACTHB-22-H-01-B1
-02	-T	SUB-ACTHB-22-G-02	SUB-ACTHB-22-H-02	NA		SUB-ACTHB-22-G-02-B1	SUB-ACTHB-22-H-02-B1
-03	-T	SUB-ACTHB-22-G-03	SUB-ACTHB-22-H-03	NA		SUB-ACTHB-22-G-03-B1	SUB-ACTHB-22-H-03-B1
-04	-T	ACTHB-22-6	ACTHB-22-6	AC-P-C-H-ST-CA1	6	NA	NA
-05	-T	SUB-ACTHB-22-G-05	SUB-ACTHB-22-H-05	NA		SUB-ACTHB-22-G-05-B1	SUB-ACTHB-22-H-05-B1
* -06	-T	SUB-ACTHB-22-G-06	SUB-ACTHB-22-H-06	AC-P-C-H-ST-CA1	4	NA	NA
-01	-S	SUB-ACSHB-22-G-01	SUB-ACSHB-22-H-01	NA		SUB-ACSHB-22-G-01-B1	SUB-ACSHB-22-H-01-B1
-02	-S	SUB-ACSHB-22-G-02	SUB-ACSHB-22-H-02	NA		SUB-ACSHB-22-G-02-B1	SUB-ACSHB-22-H-02-B1
-03	-S	SUB-ACSHB-22-G-03	SUB-ACSHB-22-H-03	NA		SUB-ACSHB-22-G-03-B1	SUB-ACSHB-22-H-03-B1
* -04	-S	ACSHB-22-6	ACSHB-22-6	AC-J-C-H-ST-CA1	6	NA	NA
-05	-S	SUB-ACSHB-22-G-05	SUB-ACSHB-22-H-05	NA		SUB-ACSHB-22-G-05-B1	SUB-ACSHB-22-H-05-B1
* -06	-S	SUB-ACSHB-22-G-06	SUB-ACSHB-22-H-06	AC-J-C-H-ST-CA1	4	NA	NA

UNLESS OTHERWISE SPECIFIED, DIMENSIONS ARE IN MILLIMETERS. TOLERANCES ARE:

DECIMALS	ANGLES
X.X: ±0.3 [01]	2°
X.XX: ±0.13 [005]	
X.XXX: ±0.051 [0020]	

PROPRIETARY NOTE  
\* THIS DOCUMENT CONTAINS CONFIDENTIAL AND PROPRIETARY INFORMATION AND ALL DESIGN, MANUFACTURING, REPRODUCTION, USE, PATENT RIGHTS AND SALES RIGHTS ARE EXPRESSLY RESERVED BY SAMTEC, INC. THIS DOCUMENT SHALL NOT BE DISCLOSED, IN WHOLE OR PART, TO ANY UNAUTHORIZED PERSON OR ENTITY NOR REPRODUCED, TRANSFERRED OR INCORPORATED IN ANY OTHER PROJECT IN ANY MANNER WITHOUT THE EXPRESS WRITTEN CONSENT OF SAMTEC, INC.



MATERIAL: DO NOT SCALE DRAWING SHEET SCALE: 1:1  
SHELL/NUT: NYLON, COLOR: BLACK  
INSULATOR: PBT, COLOR: BLACK  
O-RING: NITRILE  
COLOR RING: SILICONE  
TERMINALS: BRASS  
CONTACTS: BRASS/BeCu

DESCRIPTION: ACCLIMATE CIRC. FIELD TERM. KIT  
DWG. NO. ACRK-22-XX-X-X-XX-P-X  
BY: CLAY W 08/02/2011 SHEET 1 OF 4

-T END OPTIONS

-01: 30 POS  
Ø 1.0 TERMINALS

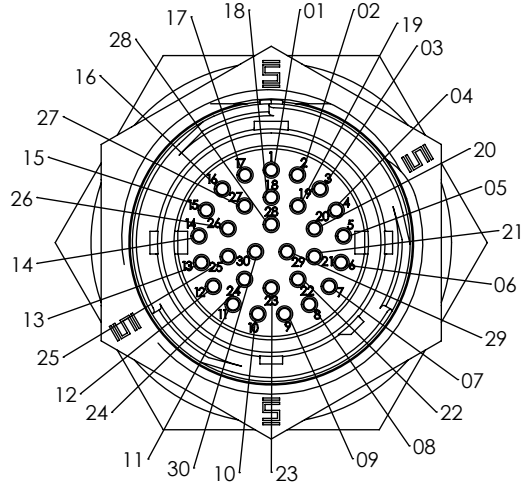

-02: 20 POS  
Ø 1.0 TERMINALS

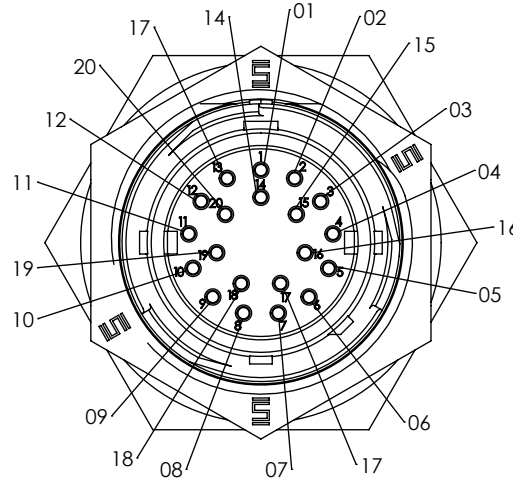

-03: 8 POS  
Ø 1.5 TERMINALS

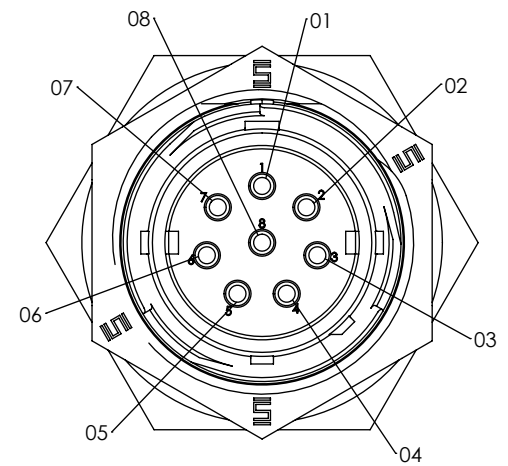

\*-04: 6 POS  
COAX PLUG

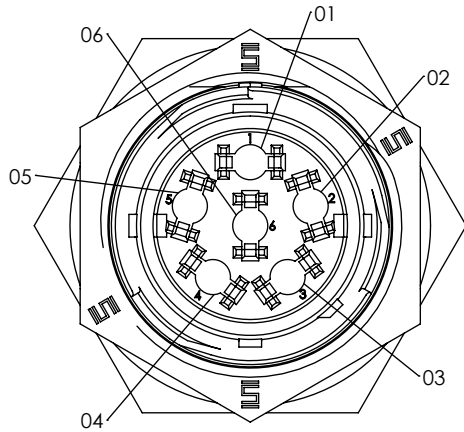

-05: 20 POS COMBO  
16 X Ø 1.0 TERMINALS  
4 X Ø 1.5 TERMINALS

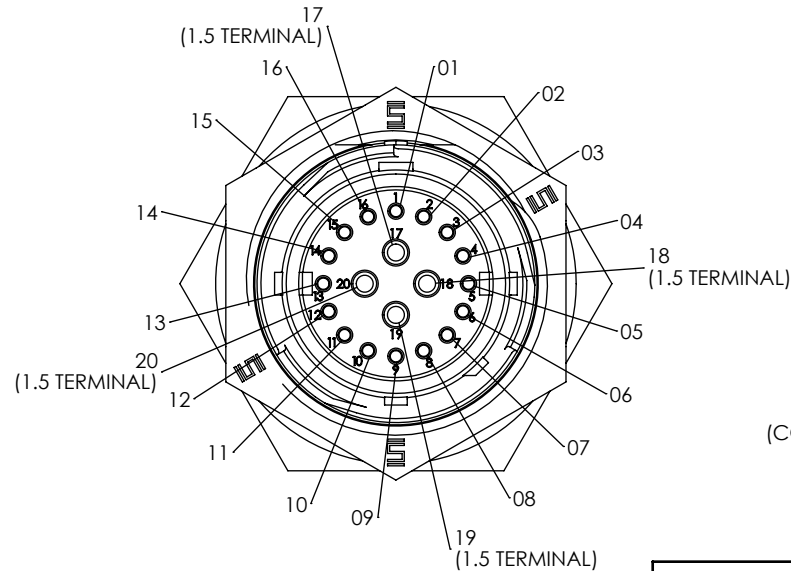

\*-06: 16 POS COMBO  
4 X COAX PLUG  
12 X Ø 1.0 TERMINALS

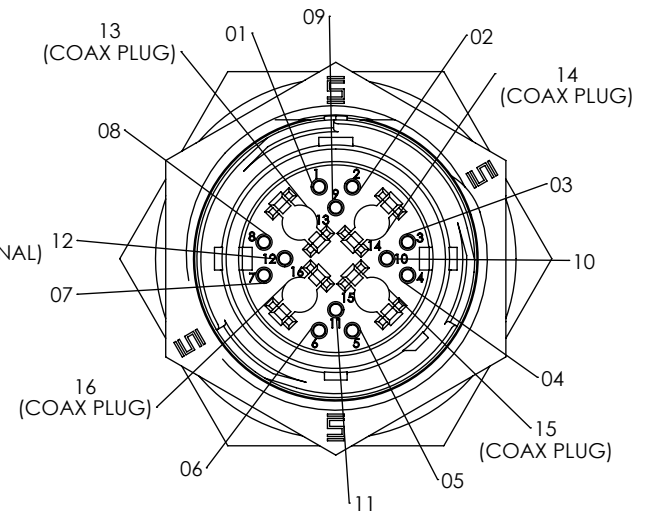

\* = NOT RELEASED FOR PRODUCTION

**PROPRIETARY NOTE**  
THIS DOCUMENT CONTAINS CONFIDENTIAL AND PROPRIETARY INFORMATION AND ALL DESIGN, MANUFACTURING, REPRODUCTION, USE, PATENT RIGHTS AND SALES RIGHTS ARE EXPRESSLY RESERVED BY SAMTEC, INC. THIS DOCUMENT SHALL NOT BE DISCLOSED, IN WHOLE OR PART, TO ANY UNAUTHORIZED PERSON OR ENTITY NOR REPRODUCED, TRANSFERRED OR INCORPORATED IN ANY OTHER PROJECT IN ANY MANNER WITHOUT THE EXPRESS WRITTEN CONSENT OF SAMTEC, INC.

DO NOT SCALE DRAWING

SHEET SCALE: 1.5:1

**samtec**

520 PARK EAST BLVD. NEW ALBANY, IN 47150  
PHONE: 812-944-6733 FAX: 812-948-5047  
e-Mail info@SAMTEC.com code 55322

DESCRIPTION: ACCLIMATE CIRC. FIELD TERM. KIT

DWG. NO. ACRK-22-XX-X-X-XX-P-X

BY: CLAY W 08/02/2011 SHEET 2 OF 4

-S END OPTIONS

-01: 30 POS  
Ø 1.0 SOCKETS

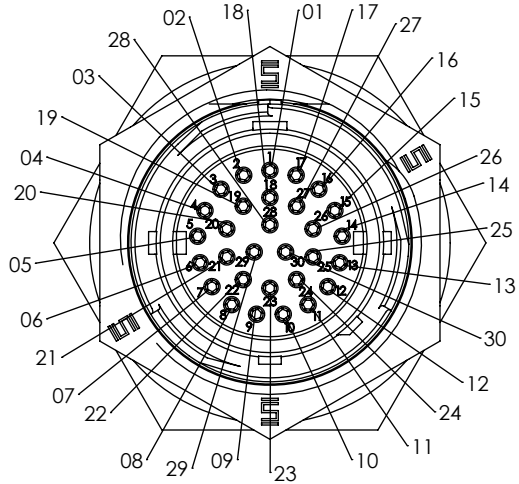

-02: 20 POS  
Ø 1.0 SOCKETS

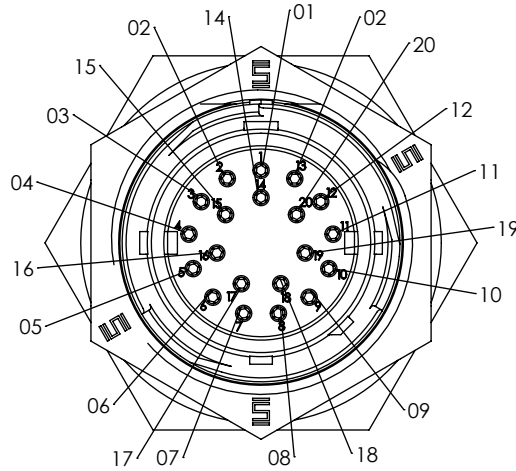

-03: 8 POS  
Ø 1.5 SOCKETS

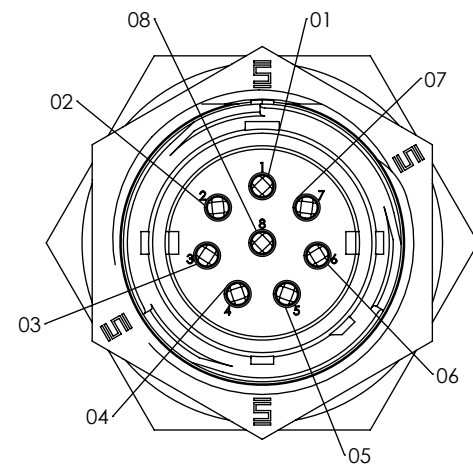

\*-04: 6 POS  
COAX JACK

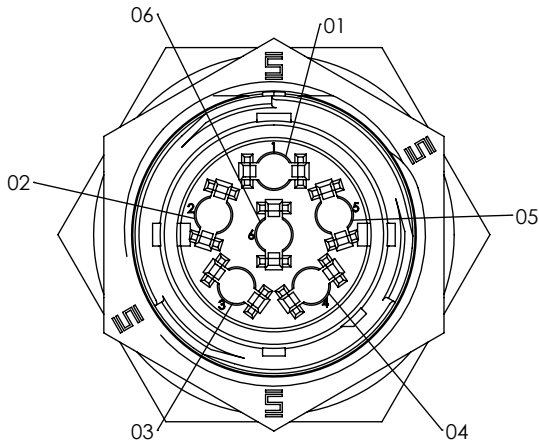

-05: 20 POS COMBO  
16 X Ø 1.0 SOCKETS  
4 X Ø 1.5 SOCKETS

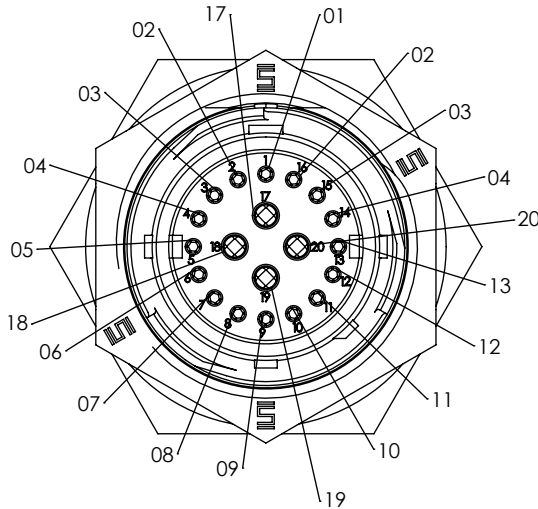

\*-06: 16 POS COMBO  
4 X COAX JACK  
12 X Ø 1.0 SOCKETS

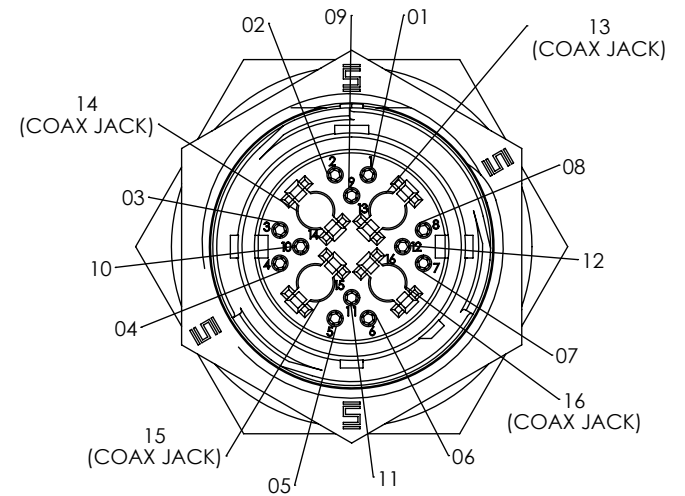

\* = NOT RELEASED FOR PRODUCTION

**PROPRIETARY NOTE**  
THIS DOCUMENT CONTAINS CONFIDENTIAL AND PROPRIETARY INFORMATION AND ALL DESIGN, MANUFACTURING, REPRODUCTION, USE, PATENT RIGHTS AND SALES RIGHTS ARE EXPRESSLY RESERVED BY SAMTEC, INC. THIS DOCUMENT SHALL NOT BE DISCLOSED, IN WHOLE OR PART, TO ANY UNAUTHORIZED PERSON OR ENTITY NOR REPRODUCED, TRANSFERRED OR INCORPORATED IN ANY OTHER PROJECT IN ANY MANNER WITHOUT THE EXPRESS WRITTEN CONSENT OF SAMTEC, INC.

DO NOT SCALE DRAWING

SHEET SCALE: 1.5:1

**samtec**

520 PARK EAST BLVD. NEW ALBANY, IN 47150  
PHONE: 812-944-6733 FAX: 812-948-5047  
e-Mail info@SAMTEC.com code 55322

DESCRIPTION: ACCLIMATE CIRC. FIELD TERM. KIT

DWG. NO. ACRK-22-XX-X-X-XX-P-X

BY: CLAY W 08/02/2011 SHEET 3 OF 4

REVISION B

**-C: SOLDER CUP**  
ACRK-22-01-X-S-C-P-1 SHOWN

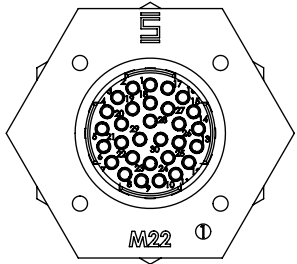
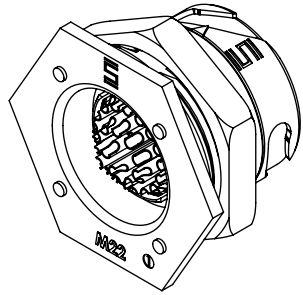

**-B1: BOARD MOUNT**  
ACRK-22-02-X-S-B1-P-1 SHOWN

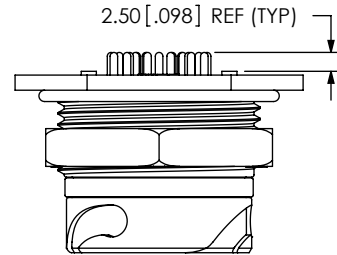
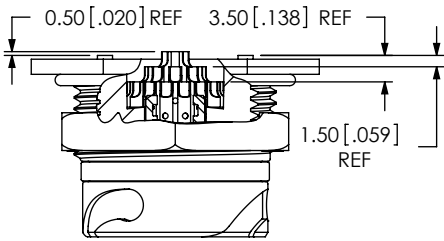
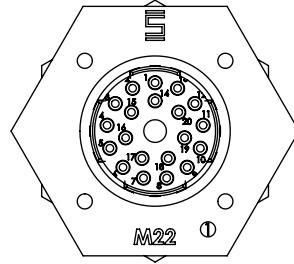
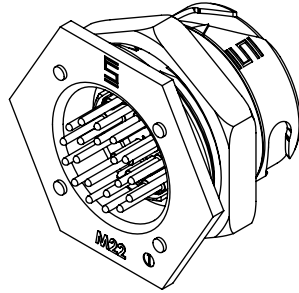

**RECOMMENDED PANEL OPENING**  
SEE NOTE 4

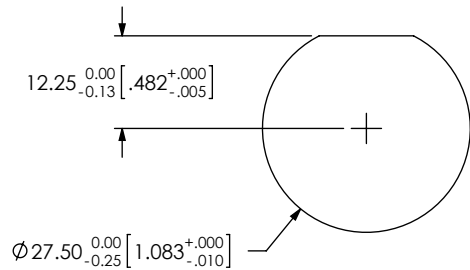

**KEY FEATURE**  
SEE NOTE 2

**-1**  
ORANGE KEY RING

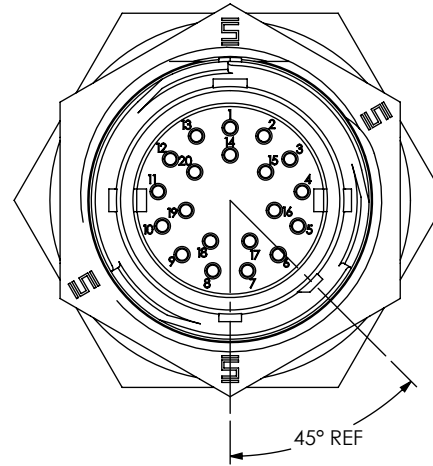

**-2**  
GREEN KEY RING

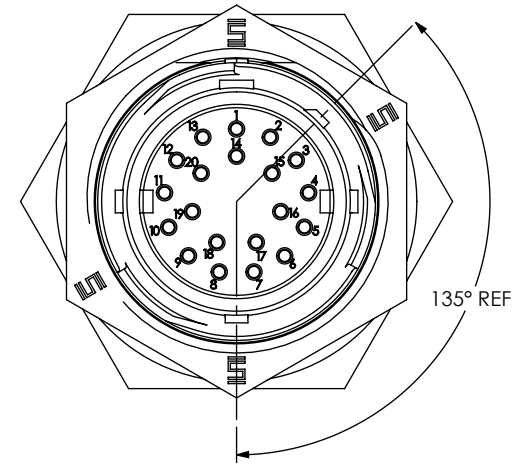

**-3**  
BLUE KEY RING

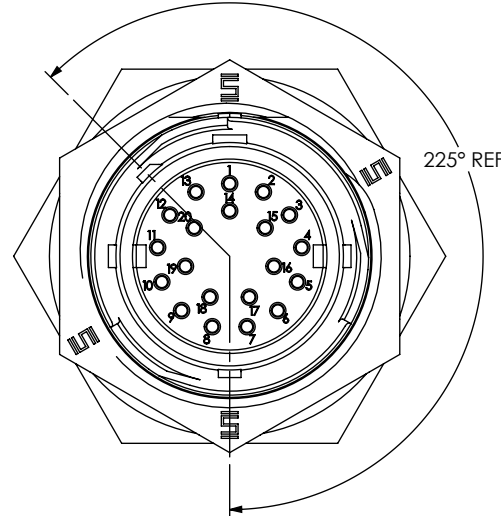

**-4**  
YELLOW KEY RING

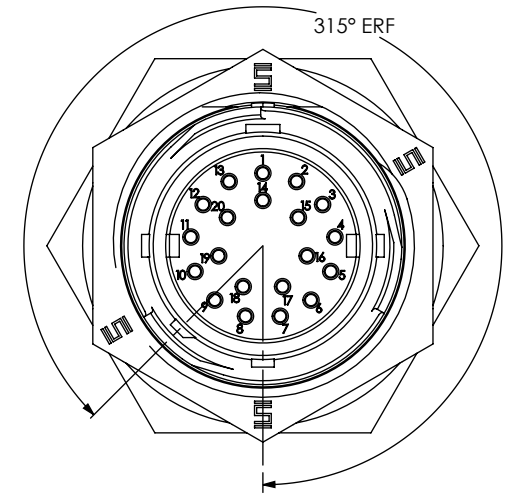

**PROPRIETARY NOTE**  
THIS DOCUMENT CONTAINS CONFIDENTIAL AND PROPRIETARY INFORMATION AND ALL DESIGN, MANUFACTURING, REPRODUCTION, USE, PATENT RIGHTS AND SALES RIGHTS ARE EXPRESSLY RESERVED BY SAMTEC, INC. THIS DOCUMENT SHALL NOT BE DISCLOSED, IN WHOLE OR PART, TO ANY UNAUTHORIZED PERSON OR ENTITY NOR REPRODUCED, TRANSFERRED OR INCORPORATED IN ANY OTHER PROJECT IN ANY MANNER WITHOUT THE EXPRESS WRITTEN CONSENT OF SAMTEC, INC.

DO NOT SCALE DRAWING

SHEET SCALE: 1:1



520 PARK EAST BLVD, NEW ALBANY, IN 47150  
PHONE: 812-944-6733 FAX: 812-948-5047  
e-Mail info@SAMTEC.com code 55322

DESCRIPTION: **ACCLIMATE CIRC. FIELD TERM. KIT**

DWG. NO. **ACRK-22-XX-X-X-XX-P-X**

BY: CLAY W 08/02/2011 SHEET 4 OF 4