

DO NOT SCALE FROM THIS PRINT

DESIGNED & DIMENSIONED IN MILLIMETERS [INCHES]

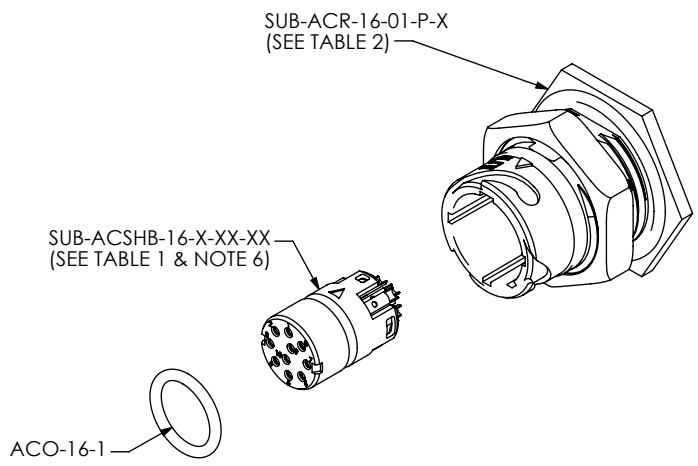

FIG 1
ACRK-16-02-X-S-C-P-1 SHOWN

ACRK-16-XX-X-X-XX-P-X

- RECEPTACLE KIT
- SIZE
- LEAD STYLE
 - 01: 14 POS (0.5 TERM/SKT), 26 - 30 AWG
 - 02: 10 POS (1.0 TERM/SKT), 20 - 24 AWG
 - 03: 4 POS PWR (1.5 TERM/SKT), 14 - 18 AWG
 - * -04: 4 POS COMBO (2 X COAX PLUG/JACK), CCA-316 (2 X 1.0 TERM/SKT), 20 - 24 AWG
 - * -05: 4 POS COMBO (3 X 1.5 TERM/SKT), 14 - 18 AWG (1 X COAX PLUG/JACK), CCA-316
 - 06: 10 POS COMBO (2 X 1.5 TERM/SKT), 14 - 18 AWG (8 X 0.5 TERM/SKT), 26 - 30 AWG
 - * -07: 7 POS COMBO (1 X COAX PLUG/JACK), CCA-316 (6 X 1.0 TERM/SKT), 20 - 24 AWG
- KEY FEATURE (SEE NOTE 2, SHT. 4)
 - 1: ORANGE
 - 2: GREEN
 - 3: BLUE
 - 4: YELLOW
- STYLE
 - P: PLASTIC
- TERMINATION (SEE SHT. 4)
 - C: SOLDER CUP
 - B1: .062 BOARD MOUNT (NOT AVAILABLE WITH -04, -05, OR -07 LEAD STYLES.)
- GENDER
 - T: TERMINAL
 - S: SOCKET
- PLATING
 - G: 10µ" GOLD ON CONTACT
 - H: 30µ" GOLD ON CONTACT

* = NOT RELEASED FOR PRODUCTION

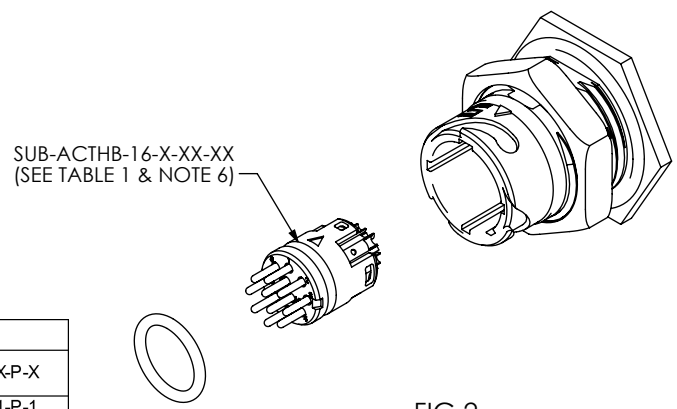

FIG 2
ACRK-16-02-X-T-C-P-1 SHOWN (SAME AS FIG 1, EXCEPT AS SHOWN)

KEY FEATURE	SUB-ACR-16-XX-P-X
-1	SUB-ACR-16-01-P-1
-2	SUB-ACR-16-01-P-2
-3	SUB-ACR-16-01-P-3
-4	SUB-ACR-16-01-P-4

LEAD STYLES	GENDER	TERMINATION					
		-C: SOLDER CUP			-B1: BOARD MOUNT		
		SUB-ASSEMBLY/HOLDER BODY PART #		COAX PLUG/JACK PART #		SUB-ASSEMBLY PART #	
		PLATING		AC-P-C-H-ST-CA1		PLATING	
		-G	-H	QTY		-G	-H
-01	-T	SUB-ACTHB-16-G-01	SUB-ACTHB-16-H-01	NA		SUB-ACTHB-16-G-01-B1	SUB-ACTHB-16-H-01-B1
-02	-T	SUB-ACTHB-16-G-02	SUB-ACTHB-16-H-02	NA		SUB-ACTHB-16-G-02-B1	SUB-ACTHB-16-H-02-B1
-03	-T	SUB-ACTHB-16-G-03	SUB-ACTHB-16-H-03	NA		SUB-ACTHB-16-G-03-B1	SUB-ACTHB-16-H-03-B1
-04	-T	SUB-ACTHB-16-G-04	SUB-ACTHB-16-H-04	AC-P-C-H-ST-CA1	2	NA	NA
-05	-T	SUB-ACTHB-16-G-05	SUB-ACTHB-16-H-05	AC-P-C-H-ST-CA1	1	NA	NA
-06	-T	SUB-ACTHB-16-G-06	SUB-ACTHB-16-H-06	NA		SUB-ACTHB-16-G-06-B1	SUB-ACTHB-16-H-06-B1
-07	-T	SUB-ACTHB-16-G-07	SUB-ACTHB-16-H-07	AC-P-C-H-ST-CA1	1	NA	NA
-01	-S	SUB-ACSHB-16-G-01	SUB-ACSHB-16-H-01	NA		SUB-ACSHB-16-G-01-B1	SUB-ACSHB-16-H-01-B1
-02	-S	SUB-ACSHB-16-G-02	SUB-ACSHB-16-H-02	NA		SUB-ACSHB-16-G-02-B1	SUB-ACSHB-16-H-02-B1
-03	-S	SUB-ACSHB-16-G-03	SUB-ACSHB-16-H-03	NA		SUB-ACSHB-16-G-03-B1	SUB-ACSHB-16-H-03-B1
-04	-S	SUB-ACSHB-16-G-04	SUB-ACSHB-16-H-04	AC-J-C-H-ST-CA1	2	NA	NA
-05	-S	SUB-ACSHB-16-G-05	SUB-ACSHB-16-H-05	AC-J-C-H-ST-CA1	1	NA	NA
-06	-S	SUB-ACSHB-16-G-06	SUB-ACSHB-16-H-06	NA		SUB-ACSHB-16-G-06-B1	SUB-ACSHB-16-H-06-B1
-07	-S	SUB-ACSHB-16-G-07	SUB-ACSHB-16-H-07	AC-J-C-H-ST-CA1	1	NA	NA

NOTES:

- KIT COMPONENTS TO BE PACKAGED IN BAGS PER PACKAGING STANDARD CO-RF-WI-3001-M.
- KEY FEATURE DETERMINES COLOR OF COLOR KEY RING AND DUSTCAP LANYARD IF APPLICABLE.
- REFER TO DCA-ACR-16-P-X PRINT FOR DUST CAP.
- PANEL THICKNESS RANGE: 0.80[.031] - 5.20[.205].
- TORQUE SPECIFICATION FOR PANEL NUT: 1.7Nm [15.00 IN-LB] - 2.3Nm [20.00 IN-LB].
- RECOMMENDED INSERTION TOOL: CAT-AC-16-M.
- NOTE DELETED.

<p>UNLESS OTHERWISE SPECIFIED, DIMENSIONS ARE IN MILLIMETERS. TOLERANCES ARE:</p> <p>DECIMALS ANGLES</p> <p>X.X: ±0.3 [.01] 2°</p> <p>X.XX: ±0.13 [.005]</p> <p>X.XXX: ±0.051 [.0020]</p>	<p>PROPRIETARY NOTE</p> <p>THIS DOCUMENT CONTAINS CONFIDENTIAL AND PROPRIETARY INFORMATION AND ALL DESIGN, MANUFACTURING, REPRODUCTION, USE, PATENT RIGHTS AND SALES RIGHTS ARE EXPRESSLY RESERVED BY SAMTEC, INC. THIS DOCUMENT SHALL NOT BE DISCLOSED, IN WHOLE OR PART, TO ANY UNAUTHORIZED PERSON OR ENTITY NOR REPRODUCED, TRANSFERRED OR INCORPORATED IN ANY OTHER PROJECT IN ANY MANNER WITHOUT THE EXPRESS WRITTEN CONSENT OF SAMTEC, INC.</p>	<p>520 PARK EAST BLVD, NEW ALBANY, IN 47150 PHONE: 812.944.6733 FAX: 812.948.5047 e-Mail: info@SAMTEC.com code 53322</p>		
			<p>DO NOT SCALE DRAWING SHEET SCALE: 1:1</p>	
			<p>MATERIAL: SHELL/NUT: NYLON, COLOR: BLACK HOLDER BODY: PBT, COLOR: BLACK O-RING: NITRILE COLOR RING: SILICONE TERMINALS: BRASS CONTACTS: BRASS/BeCu</p>	
<p>DESCRIPTION: ACCIMATE CIRC. FIELD TERM. KIT</p>				
<p>DWG. NO. ACRK-16-XX-X-X-XX-P-X</p>				
<p>BY: J. BORGELT 3/7/2011</p>		<p>SHEET 1 OF 4</p>		

-T END OPTIONS

-01: 14 POS
Ø0.5 TERMINALS

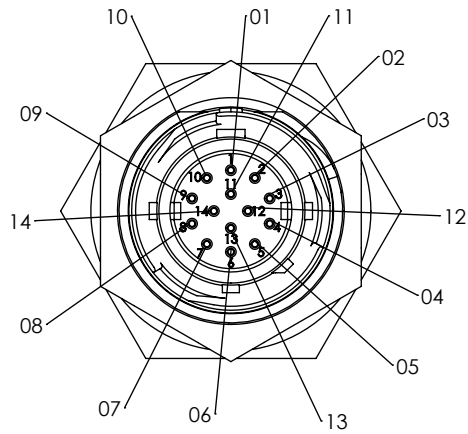

-02: 10 POS
Ø1.0 TERMINALS

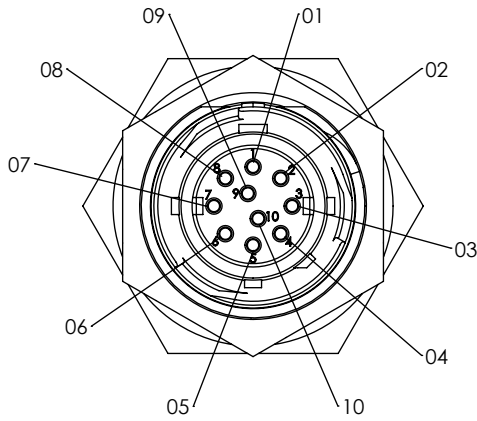

-03: 4 POS
Ø1.5 TERMINALS

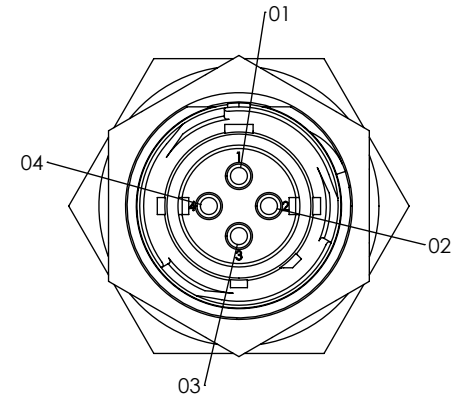

-04: 3 POS COMBO
2 X COAX PLUGS
2 X Ø1.0 TERMINALS

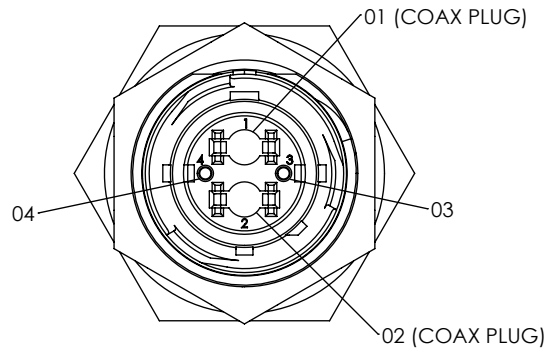

-05: 4 POS COMBO
3 X Ø1.5 TERMINALS
1 X COAX PLUG

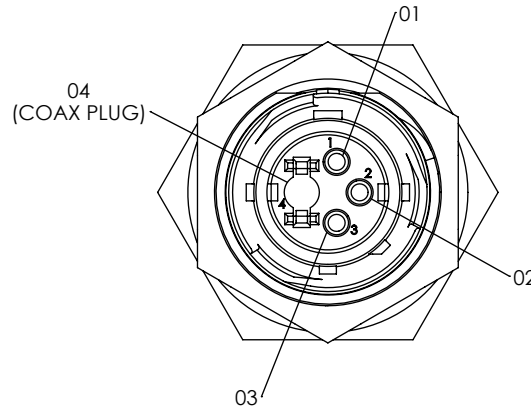

-06: 10 POS COMBO
2 X Ø1.5 TERMINALS
8 X Ø0.5 TERMINALS

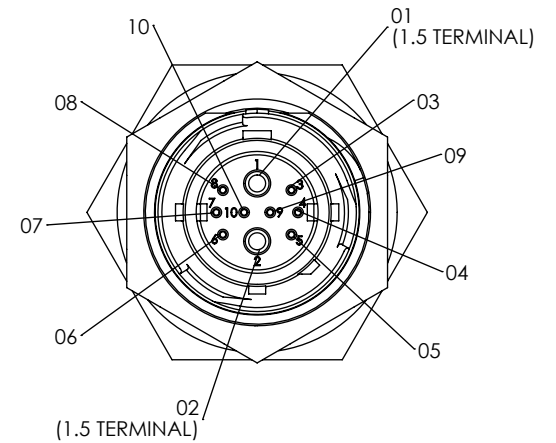

-07: 7 POS COMBO
1 X COAX PLUG
6 X Ø1.0 TERMINALS

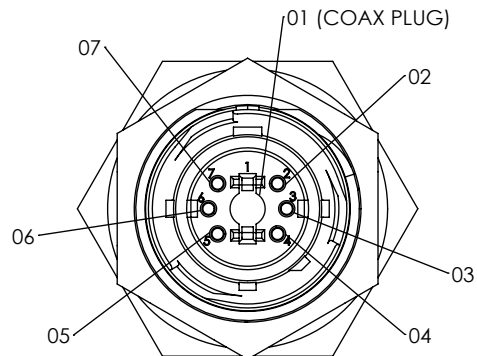

PROPRIETARY NOTE
THIS DOCUMENT CONTAINS CONFIDENTIAL AND PROPRIETARY INFORMATION AND ALL DESIGN, MANUFACTURING, REPRODUCTION, USE, PATENT RIGHTS AND SALES RIGHTS ARE EXPRESSLY RESERVED BY SAMTEC, INC. THIS DOCUMENT SHALL NOT BE DISCLOSED, IN WHOLE OR PART, TO ANY UNAUTHORIZED PERSON OR ENTITY NOR REPRODUCED, TRANSFERRED OR INCORPORATED IN ANY OTHER PROJECT IN ANY MANNER WITHOUT THE EXPRESS WRITTEN CONSENT OF SAMTEC, INC.

DO NOT SCALE DRAWING

SHEET SCALE: 1.5:1



520 PARK EAST BLVD, NEW ALBANY, IN 47150
PHONE: 812-944-6733 FAX: 812-948-5047
e-Mail info@SAMTEC.com code 55322

DESCRIPTION: ACCLIMATE CIRC. FIELD TERM. KIT

DWG. NO. ACRK-16-XX-X-X-XX-P-X

BY: J. BORGELT 3/7/2011 SHEET 2 OF 4

-S END OPTIONS

-01: 14 POS
Ø0.5 SOCKETS

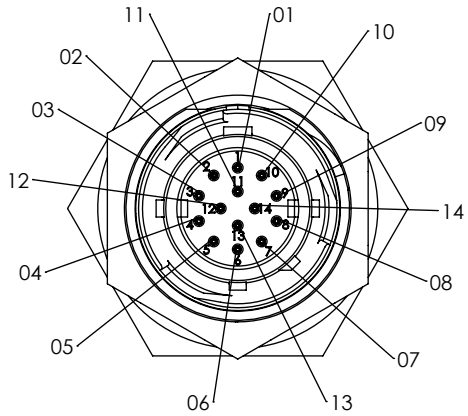

-02: 10 POS
Ø1.0 SOCKETS

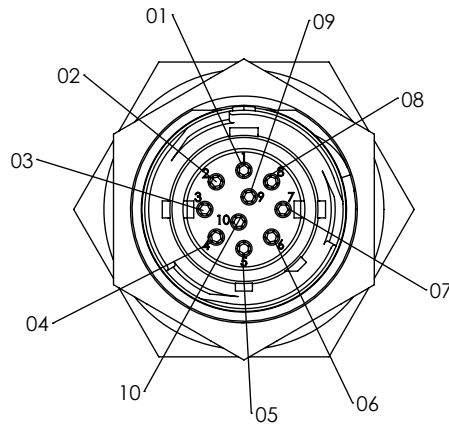

-03: 4 POS
Ø1.5 SOCKETS

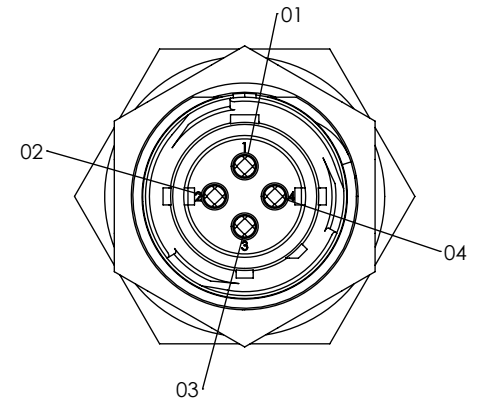

-04: 4 POS COMBO
2 X COAX JACKS
2 X Ø1.0 TERMINALS

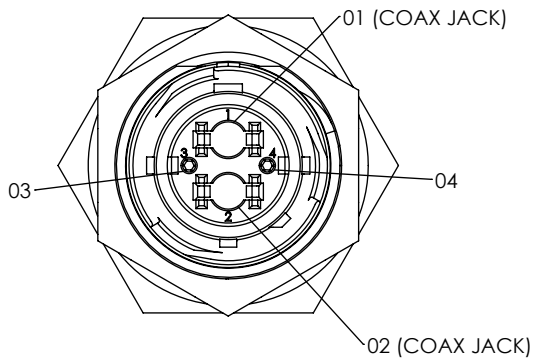

-05: 4 POS COMBO
3 X Ø1.5 SOCKETS
1 X COAX JACK

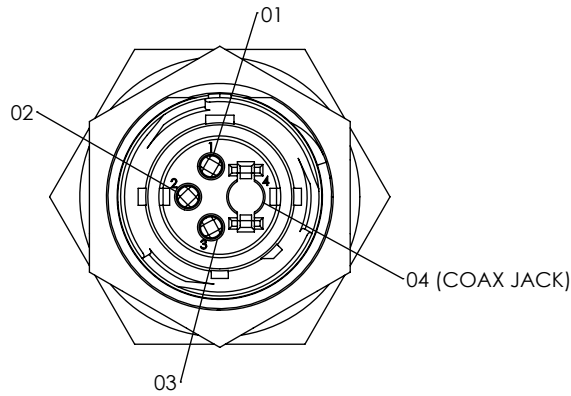

-06: 10 POS COMBO
2 X Ø1.5 SOCKETS
8 X Ø0.5 SOCKETS

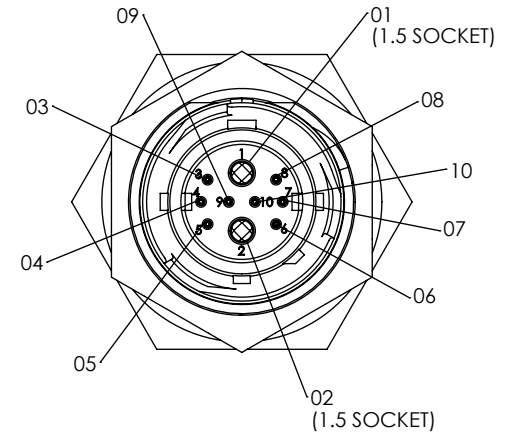

-07: 7 POS COMBO
1 X COAX JACK
6 X Ø1.0 SOCKETS

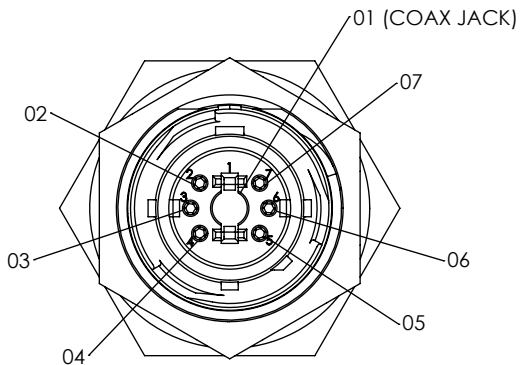

PROPRIETARY NOTE
THIS DOCUMENT CONTAINS CONFIDENTIAL AND PROPRIETARY INFORMATION AND ALL DESIGN, MANUFACTURING, REPRODUCTION, USE, PATENT RIGHTS AND SALES RIGHTS ARE EXPRESSLY RESERVED BY SAMTEC, INC. THIS DOCUMENT SHALL NOT BE DISCLOSED, IN WHOLE OR PART, TO ANY UNAUTHORIZED PERSON OR ENTITY NOR REPRODUCED, TRANSFERRED OR INCORPORATED IN ANY OTHER PROJECT IN ANY MANNER WITHOUT THE EXPRESS WRITTEN CONSENT OF SAMTEC, INC.

DO NOT SCALE DRAWING

SHEET SCALE: 1.5:1



520 PARK EAST BLVD, NEW ALBANY, IN 47150
PHONE: 812-944-6733 FAX: 812-948-5047
e-Mail info@SAMTEC.com code 55322

DESCRIPTION: ACCLIMATE CIRC. FIELD TERM. KIT

DWG. NO. ACRK-16-XX-X-X-XX-P-X

BY: J. BORGELT 3/7/2011 SHEET 3 OF 4

REVISION B

-C: SOLDER CUP
ACRK-16-02-X-S-C-P-1 SHOWN

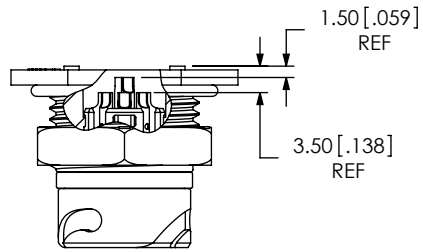
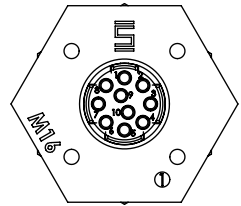
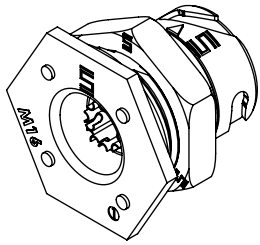

-B1: BOARD MOUNT
ACRK-16-02-X-S-B1-P-1 SHOWN

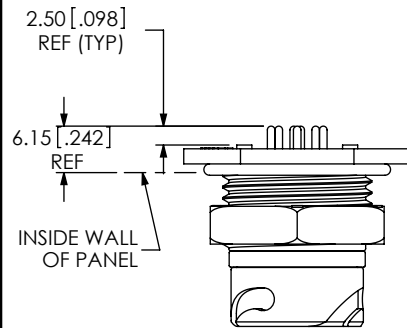
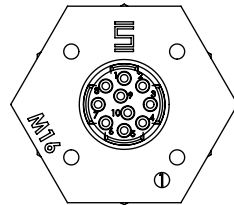
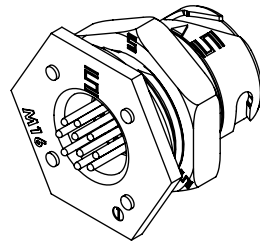

RECOMMENDED PANEL OPENING
SEE NOTE 4

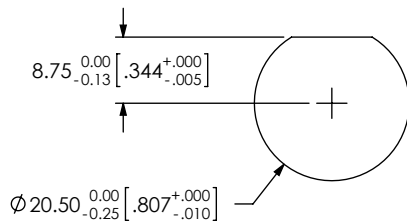

KEY FEATURE
SEE NOTE 2

-1
ORANGE KEY RING

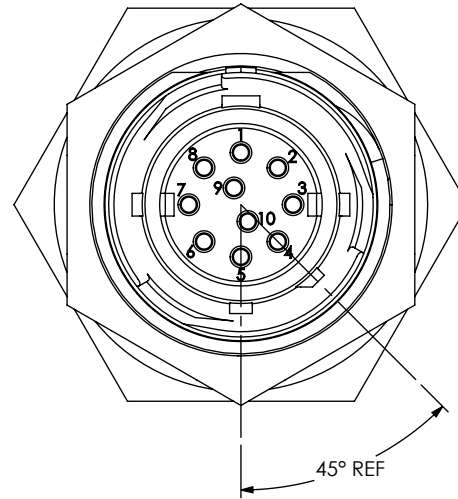

-2
GREEN KEY RING

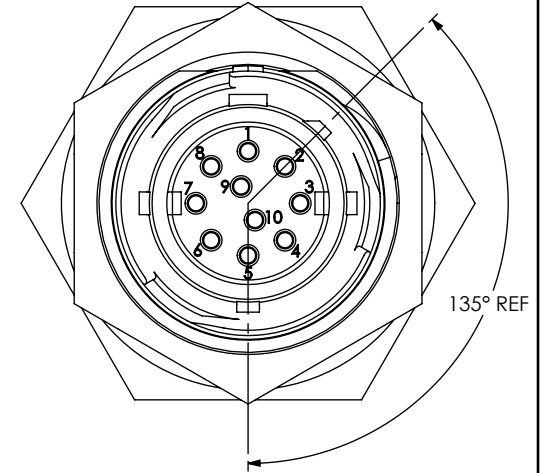

-3
BLUE KEY RING

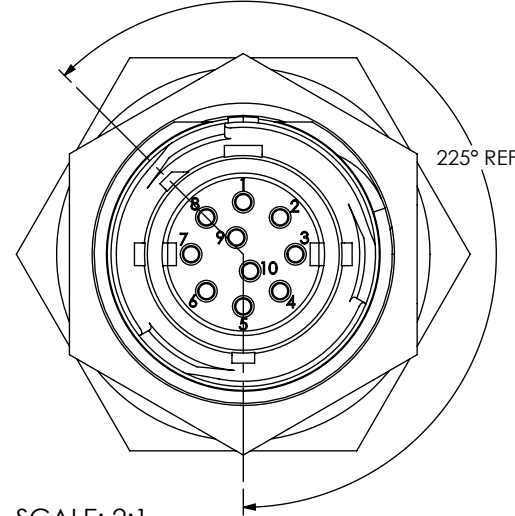

-4
YELLOW KEY RING

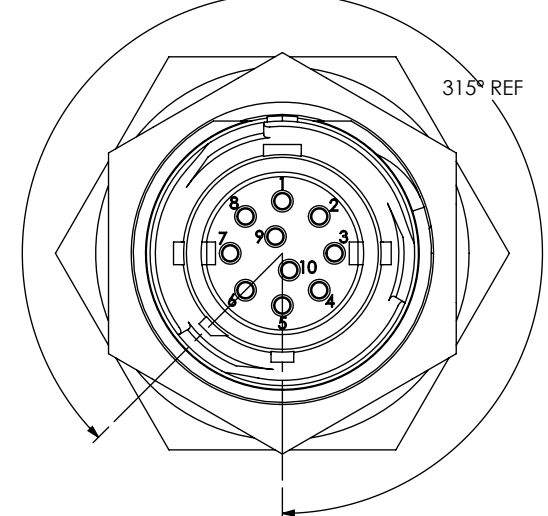

SCALE: 2:1

PROPRIETARY NOTE

THIS DOCUMENT CONTAINS CONFIDENTIAL AND PROPRIETARY INFORMATION AND ALL DESIGN, MANUFACTURING, REPRODUCTION, USE, PATENT RIGHTS AND SALES RIGHTS ARE EXPRESSLY RESERVED BY SAMTEC, INC. THIS DOCUMENT SHALL NOT BE DISCLOSED, IN WHOLE OR PART, TO ANY UNAUTHORIZED PERSON OR ENTITY NOR REPRODUCED, TRANSFERRED OR INCORPORATED IN ANY OTHER PROJECT IN ANY MANNER WITHOUT THE EXPRESS WRITTEN CONSENT OF SAMTEC, INC.

DO NOT SCALE DRAWING

SHEET SCALE: 1:1



520 PARK EAST BLVD, NEW ALBANY, IN 47150
PHONE: 812-944-6733 FAX: 812-948-5047
e-Mail info@SAMTEC.com code 55322

DESCRIPTION: ACCLIMATE CIRC. FIELD TERM. KIT

DWG. NO. ACRK-16-XX-X-X-XX-P-X

BY: J. BORGELT 3/7/2011 SHEET 4 OF 4