

DESIGNED & DIMENSIONED
IN MILLIMETERS[INCHES]

Pb THIS PRODUCT MANUFACTURED
WITH LEAD-FREE PROCESSING

DO NOT
SCALE FROM
THIS PRINT

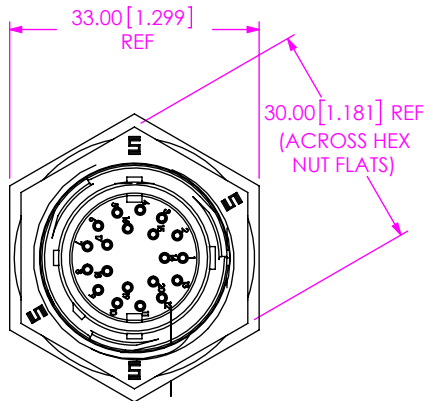
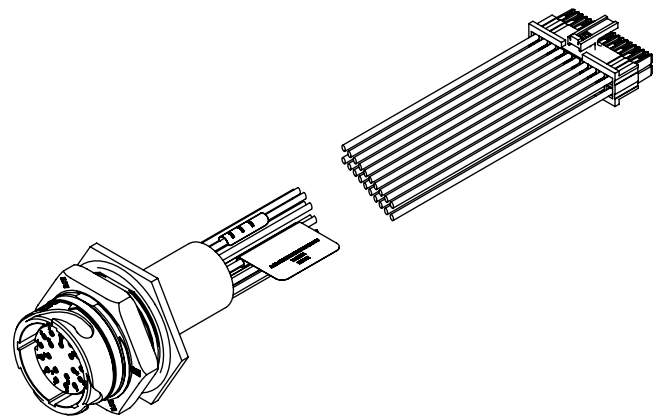

ACR-22-XX-X-XX.XX-X-XX-P-X

- LEAD STYLE**
 - 01: 30 POS (1.0 TERM/SKT), 24 AWG
 - 02: 20 POS (1.0 TERM/SKT), 24 AWG
 - 03: 8 POS PWR(1.5 TERM/SKT), 16 AWG
 - 04: 6 POS (COAX PLUG/JACK), COAX (ONLY AVAILABLE WITH -H PLATING)
 - 05: 20 POS COMBO (4 X 1.5 TERM/SKT), 16 AWG (16 X 1.0 TERM/SKT), 24 AWG
 - 06: 16 POS COMBO (4 X COAX PLUG/JACK), COAX (12 X 1.0 TERM/SKT), 24 AWG
- KEYING FEATURE** (SEE NOTE 4)(SEE SHEET 6)
 - 1: ORANGE
 - 2: GREEN
 - 3: BLUE
 - 4: YELLOW
- STYLE**
 - P: PLASTIC
- END 2**
 - BC: BLUNT CUT CONNECTOR (DETERMINED BY LEAD STYLE)
 - S1: CONNECTOR (DETERMINED BY LEAD STYLE)
- END 1**
 - T: TERMINAL
 - S: SOCKET
- PLATING** (SEE NOTE 10 & 14)
 - G: LIGHT, 10µ AU / 50µ NI MIN ON CONTACT
 - H: HEAVY, 30µ AU / 50µ NI MIN ON CONTACT
- ASSEMBLED LENGTH**
 - XX.XX (IN METERS) (00.20 METER MIN TO 50.00 METER MAX)

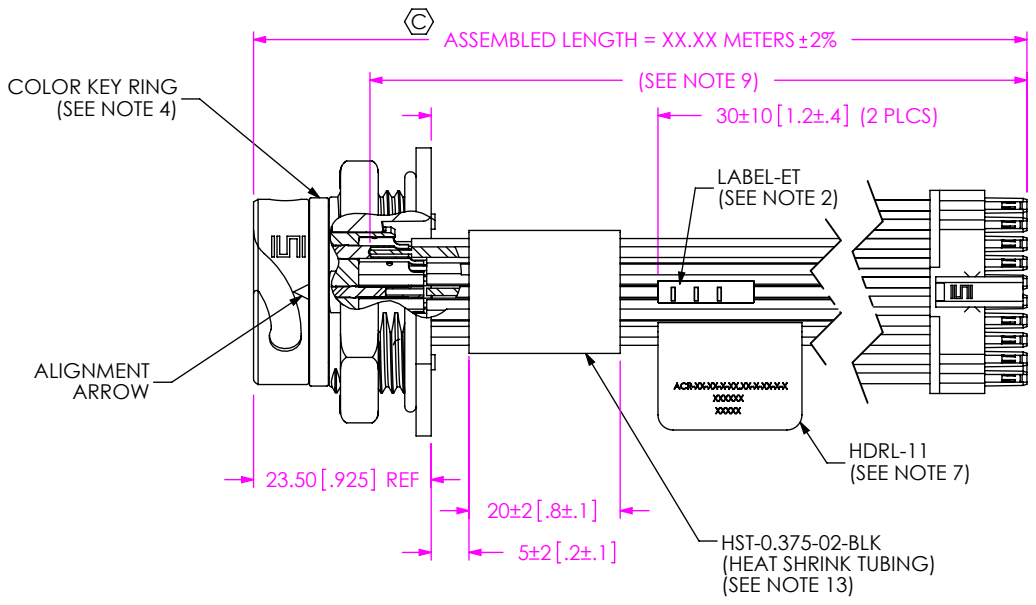

FIG 1
ACR-22-02-X-XX.XX-S-S1-P-1 SHOWN

NOTES:

- ⊕ REPRESENTS A CRITICAL DIMENSION.
- ASSEMBLY TO BE 100% HI-POT TESTED AT 300V. (1) LABEL-ET TO BE APPLIED AFTER FINAL ELECTRICAL TEST.
- ASSEMBLIES TO BE BULK PACKAGED.
- KEYING FEATURE DETERMINES COLOR OF KEY RING AND DUSTCAP LANYARD IF APPLICABLE.
- SIGNAL MAPPING IS 1 TO 1, 2 TO 2, 3 TO 3, ETC..
- REFER TO DCA-ACR-22-P-X PRINT FOR DUST CAP.
- PLACE HDRL-11 (LABEL) IN FLAG STYLE, ON CABLE WHERE SHOWN. LABEL TO CONTAIN:
LINE 1 - PART NUMBER "ACR-22-XX-X-XX.XX-X-XX-P-X"
LINE 2 - SHOP ORDER NUMBER "XXXXXX"
LINE 3 - DATE CODE "XXXXX"
- PANEL THICKNESS RANGE: 0.80[0.031] - 5.20[0.205]
- FOR END 2 CABLE LENGTH, REFERENCE END 2 OPTIONS ON SHEET 4.
- END 2 CONNECTOR PLATING:
MPSS & MMSD: 10µ MIN GOLD.
RF316: 30µ MIN GOLD ON INNER CONTACT
3µ MIN GOLD ON OUTER CONTACT
3µ MIN GOLD ON REMAINING METAL PARTS.
- NOTE DELETED.
- WHEN MOUNTING PRODUCT TO PANEL TORQUE ACPN-22-P TO 15 IN-LBS.
- APPLY HEAT SHRINK TUBING TO -01, -02, -05, & -06 LEAD STYLES.
- PLATING CALLOUTS APPLY TO END 1 TERMINALS & SOCKETS ONLY. COAX PLUGS/JACKS HAVE -H PLATING ON INNER TERMINALS/SOCKETS & -F PLATING ON OUTER SHELLS.
- MINIMUM BEND RADIUS FOR COAX CABLE IS 25.4[1.00].

UNLESS OTHERWISE SPECIFIED,
DIMENSIONS ARE IN MILLIMETERS.
TOLERANCES ARE:
DECIMALS ANGLES
X.X: ±0.3 [.01] 2°
X.XX: ±0.13 [.005]
X.XXX: ±0.051 [.0020]

PROPRIETARY NOTE
THIS DOCUMENT CONTAINS CONFIDENTIAL AND PROPRIETARY INFORMATION AND ALL DESIGN, MANUFACTURING, REPRODUCTION, USE, PATENT RIGHTS AND SALES RIGHTS ARE EXPRESSLY RESERVED BY SAMTEC, INC. THIS DOCUMENT SHALL NOT BE DISCLOSED, IN WHOLE OR PART, TO ANY UNAUTHORIZED PERSON OR ENTITY NOR REPRODUCED, TRANSFERRED OR INCORPORATED IN ANY OTHER PROJECT IN ANY MANNER WITHOUT THE EXPRESS WRITTEN CONSENT OF SAMTEC, INC.

MATERIAL: DO NOT SCALE DRAWING SHEET SCALE: 2:1
SHELL: NYLON, COLOR: BLACK
HOLDER BODY: PBT, COLOR: BLACK
TERMINALS: BRASS
CONTACTS: BRASS/BeCu
BAYONET COLLAR: NYLON, COLOR: BLACK
CABLE NUT: NYLON, COLOR: BLACK
GROMMET: NBR
GROMMET CAGE: NYLON, COLOR: BLACK
COLOR RINGS: SILICONE



520 PARK EAST BLVD, NEW ALBANY, IN 47150
PHONE: 812-944-6733 FAX: 812-948-5047
e-Mail: info@SAMTEC.com code 53322

DESCRIPTION:	M22 CABLE ASSEMBLY
DWG. NO.	ACR-22-XX-X-XX.XX-X-XX-P-X
BY:	CLAY W 9/8/2010 SHEET 1 OF 8

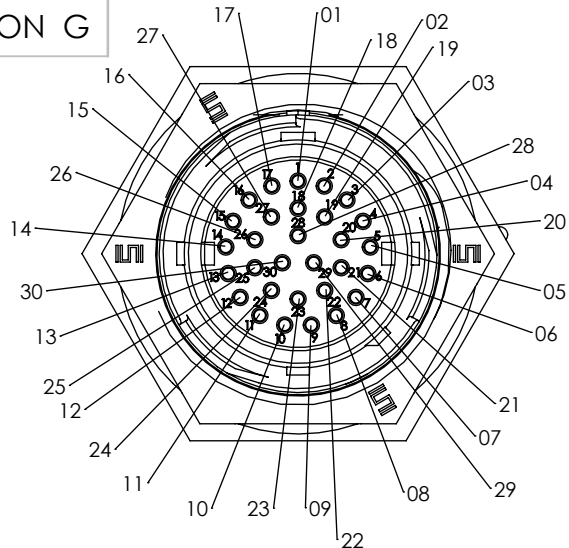

-01: 30 POS
(ϕ 1.0 TERMINALS)

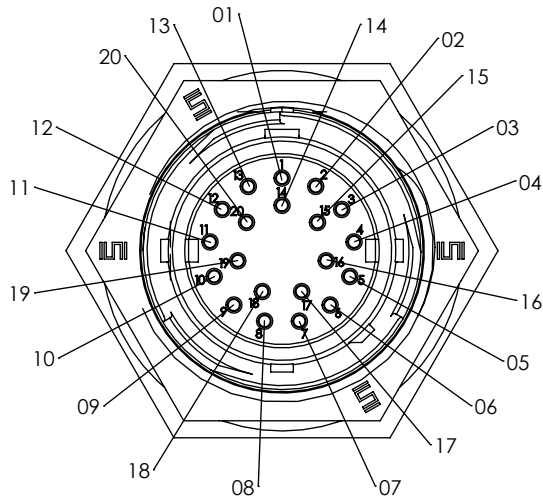

-02: 20 POS
(ϕ 1.0 TERMINALS)

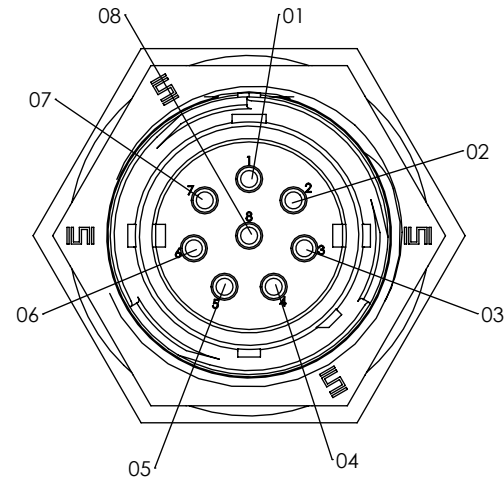

-03: 8 POS
(ϕ 1.5 TERMINALS)

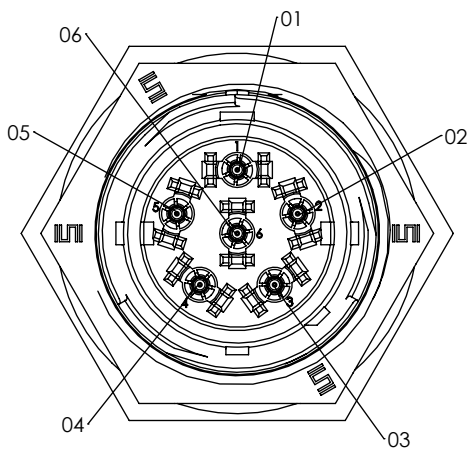

-04: 6 POS
(COAX PLUGS)

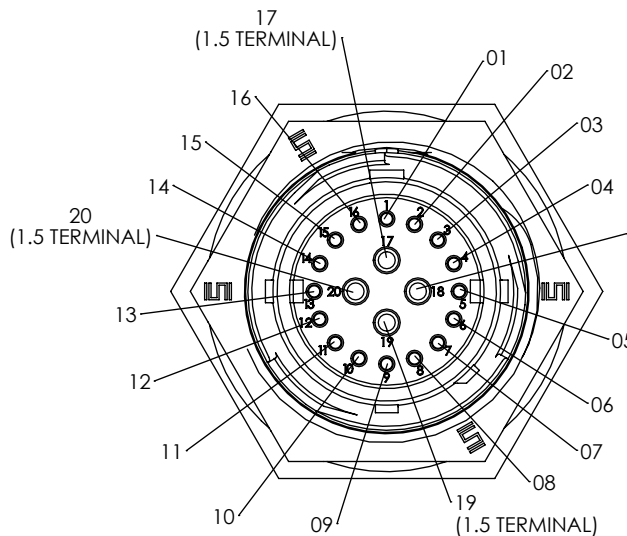

-05: 20 POS COMBO
(4X ϕ 1.5 TERMINALS)
(16 X ϕ 1.0 TERMINALS)

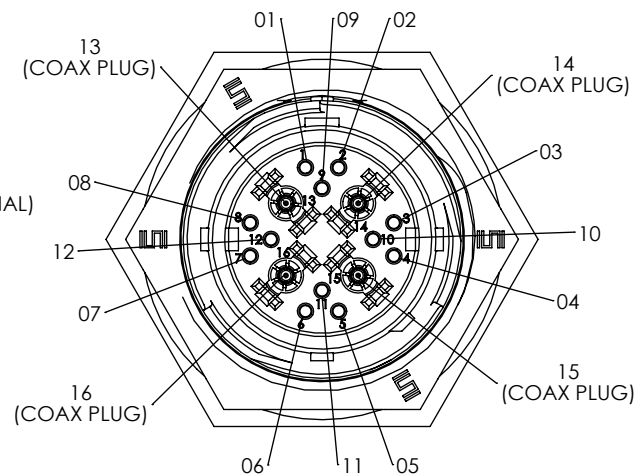

-06: 16 POS COMBO
(4 X COAX PLUGS)
(12 X 1.0 ϕ TERMINALS)

-T END OPTIONS

PROPRIETARY NOTE
THIS DOCUMENT CONTAINS CONFIDENTIAL AND PROPRIETARY INFORMATION AND ALL DESIGN, MANUFACTURING, REPRODUCTION, USE, PATENT RIGHTS AND SALES RIGHTS ARE EXPRESSLY RESERVED BY SAMTEC, INC. THIS DOCUMENT SHALL NOT BE DISCLOSED, IN WHOLE OR PART, TO ANY UNAUTHORIZED PERSON OR ENTITY NOR REPRODUCED, TRANSFERRED OR INCORPORATED IN ANY OTHER PROJECT IN ANY MANNER WITHOUT THE EXPRESS WRITTEN CONSENT OF SAMTEC, INC.

DO NOT SCALE DRAWING

SHEET SCALE: 1.5:1



520 PARK EAST BLVD, NEW ALBANY, IN 47150
PHONE: 812-944-6733 FAX: 812-948-5047
e-Mail info@SAMTEC.com code 55322

DESCRIPTION: M22 CABLE ASSEMBLY

DWG. NO. ACR-22-XX-X-XX.XX-X-XX-P-X

BY: CLAY W 9/8/2010 SHEET 2 OF 8

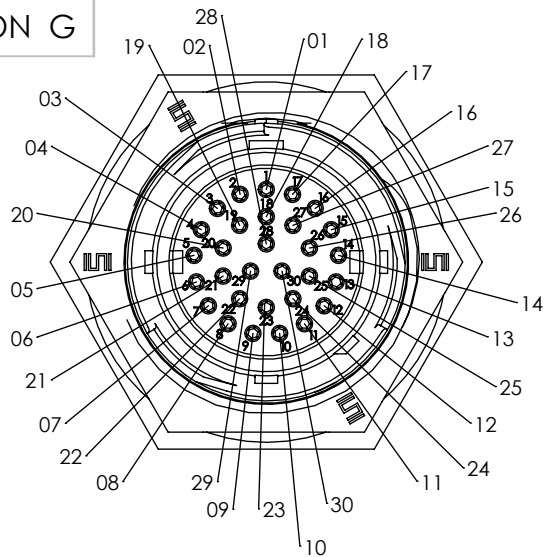

-01: 30 POS
(\varnothing 1.0 SOCKETS)

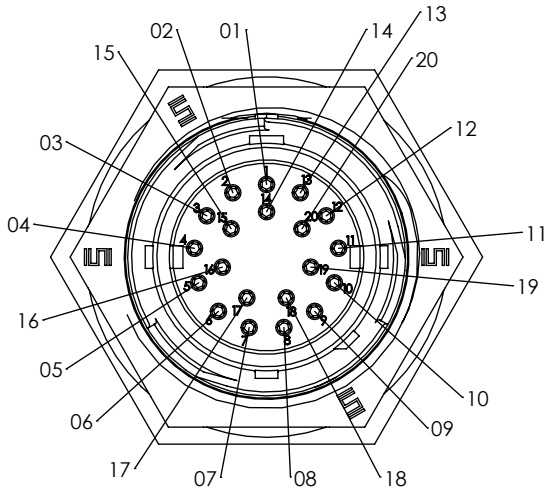

-02: 20 POS
(\varnothing 1.0 SOCKETS)

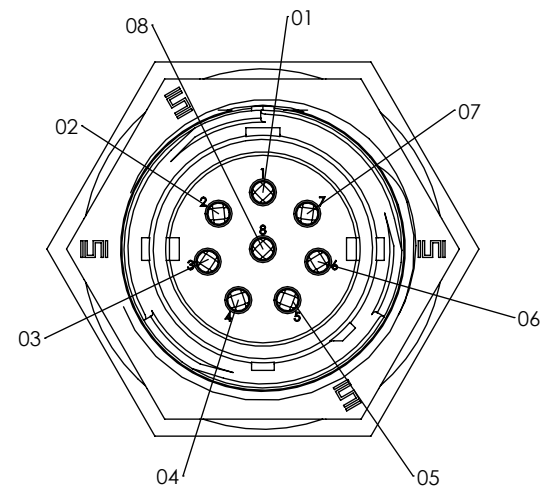

-03: 8 POS
(\varnothing 1.5 SOCKETS)

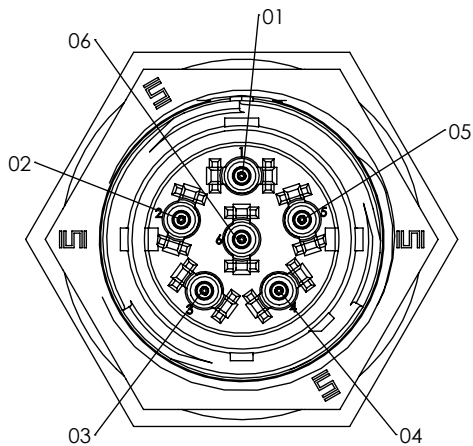

-04: 6 POS
(COAX JACK)

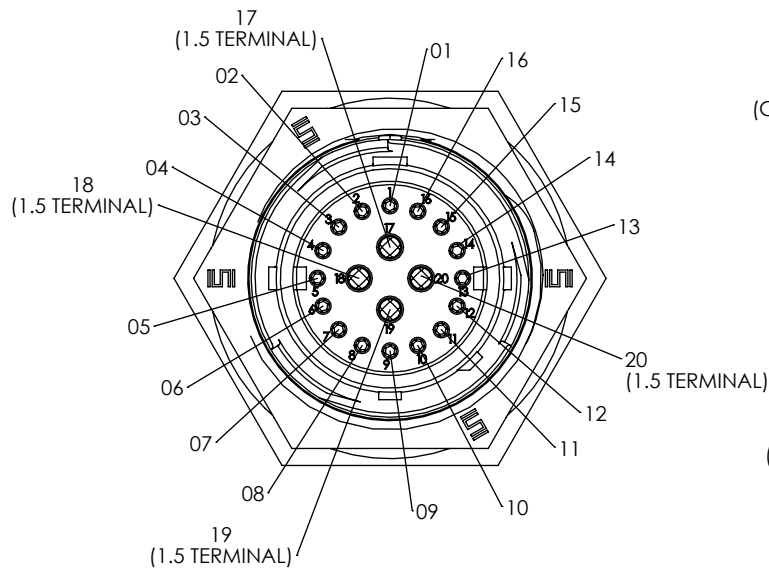

-05: 20 POS COMBO
(4 X \varnothing 1.5 SOCKETS)
(16 X \varnothing 1.0 SOCKETS)

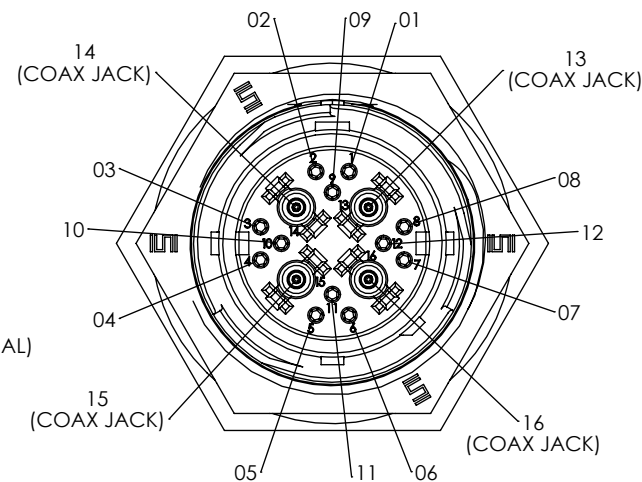

-06: 16 POS COMBO
4 X COAX JACK
12 X 1.0 SOCKETS

-S END OPTIONS

PROPRIETARY NOTE
THIS DOCUMENT CONTAINS CONFIDENTIAL AND PROPRIETARY INFORMATION AND ALL DESIGN, MANUFACTURING, REPRODUCTION, USE, PATENT RIGHTS AND SALES RIGHTS ARE EXPRESSLY RESERVED BY SAMTEC, INC. THIS DOCUMENT SHALL NOT BE DISCLOSED, IN WHOLE OR PART, TO ANY UNAUTHORIZED PERSON OR ENTITY NOR REPRODUCED, TRANSFERRED OR INCORPORATED IN ANY OTHER PROJECT IN ANY MANNER WITHOUT THE EXPRESS WRITTEN CONSENT OF SAMTEC, INC.

DO NOT SCALE DRAWING

SHEET SCALE: 1.5:1



520 PARK EAST BLVD, NEW ALBANY, IN 47150
PHONE: 812-944-6733 FAX: 812-948-5047
e-Mail info@SAMTEC.com code 55322

DESCRIPTION: M22 CABLE ASSEMBLY

DWG. NO. ACR-22-XX-X-XX.XX-X-XX-P-X

BY: CLAY W 9/8/2010 SHEET 3 OF 8

MMSD ASSEMBLED LENGTH =
(XX.XX (METERS) X 39.37) -0.63

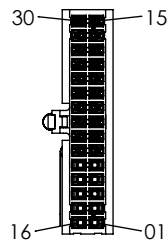
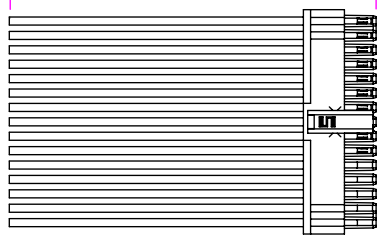

-01: 30 POS
(MMSD-15-24-L-XX.XX-S-K)

MMSD ASSEMBLED LENGTH =
(XX.XX (METERS) X 39.37) -0.63

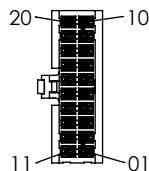
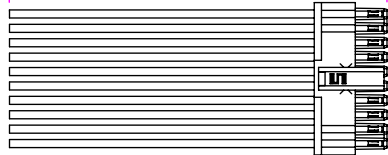

-02: 20 POS
(MMSD-10-24-L-XX.XX-S-K)

MPSS ASSEMBLED LENGTH =
(XX.XX (METERS) X 39.37) -0.63

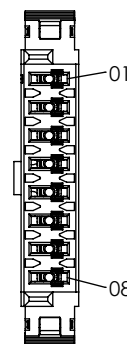
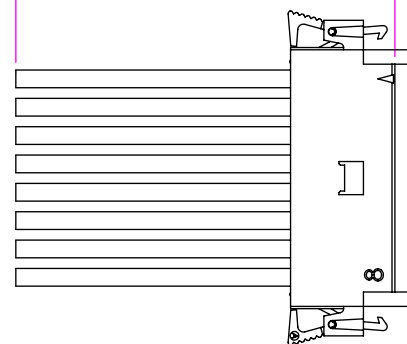

-03: 8 POS
(MPSS-08-16-L-XX.XX-SR)

RF316A O.A. CABLE LENGTH =
(XX.XX (METERS) X 1000) - 7.80
(SEE NOTE 15)

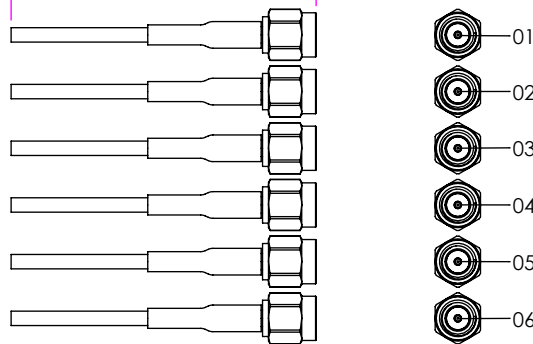

-04: 6 POS
(6 X RF316A-01SP1-SING-XXXX)

MMSD ASSEMBLED LENGTH =
(XX.XX (METERS) X 39.37) -0.63

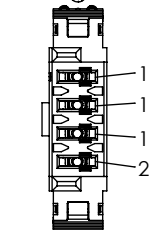
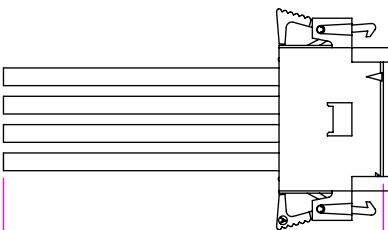
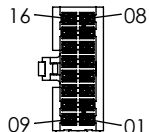
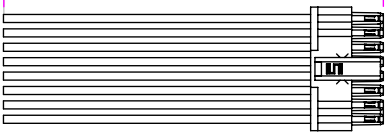

MPSS ASSEMBLED LENGTH =
(XX.XX (METERS) X 39.37) -0.63

-05: 20 POS COMBO
(1 X MMSD-08-24-L-XX.XX-S-K)
(1 X MPSS-04-16-L-XX.XX-SR)

MMSD ASSEMBLED LENGTH =
(XX.XX (METERS) X 39.37) -0.63

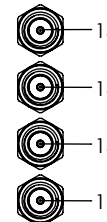
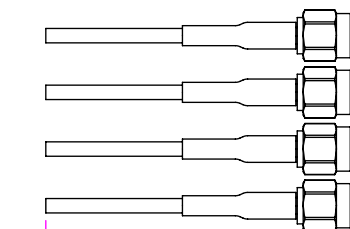
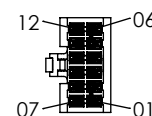
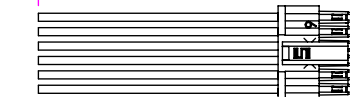

RF316A O.A. CABLE LENGTH =
(XX.XX METERS X 1000) - 7.80
(SEE NOTE 15)

-06: 16 POS COMBO
(1 X MMSD-06-24-L-XX.XX-S-K)
(4 X RF316A-01SP1-SING-XXXX)

PROPRIETARY NOTE

THIS DOCUMENT CONTAINS CONFIDENTIAL AND PROPRIETARY INFORMATION AND ALL DESIGN, MANUFACTURING, REPRODUCTION, USE, PATENT RIGHTS AND SALES RIGHTS ARE EXPRESSLY RESERVED BY SAMTEC, INC. THIS DOCUMENT SHALL NOT BE DISCLOSED, IN WHOLE OR PART, TO ANY UNAUTHORIZED PERSON OR ENTITY NOR REPRODUCED, TRANSFERRED OR INCORPORATED IN ANY OTHER PROJECT IN ANY MANNER WITHOUT THE EXPRESS WRITTEN CONSENT OF SAMTEC, INC.

DO NOT SCALE DRAWING

SHEET SCALE: 3:4



520 PARK EAST BLVD, NEW ALBANY, IN 47150
PHONE: 812-944-6733 FAX: 812-948-5047
e-Mail info@SAMTEC.com code 55322

DESCRIPTION: M22 CABLE ASSEMBLY

DWG. NO. ACR-22-XX-X-XX.XX-X-XX-P-X

BY: CLAY W 9/8/2010 SHEET 4 OF 8

-BC END 2 OPTION
 BUILD DOUBLE-ENDED INITIALLY FOR E-TEST
 (SEE IN-PROCESS 7)

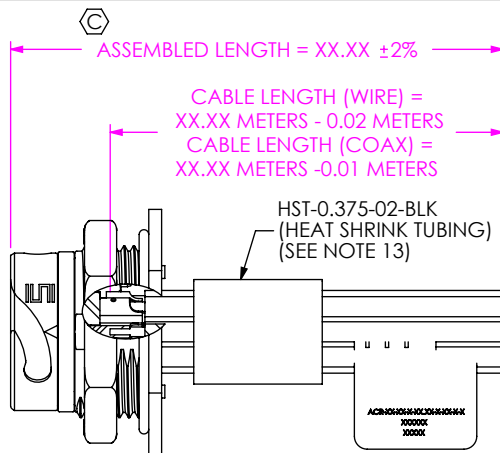

TABLE 2												
LEAD STYLE												
POSITION	-01		-02		-03		-04		-05		-06	
	COLOR	DWC-XX-XX-XXX	COLOR	DWC-XX-XX-XXX	COLOR	DWC-XX-XX-XXX	COLOR	DWC-XX-XX-XXX	COLOR	DWC-XX-XX-XXX	COLOR	DWC-XX-XX-XXX
01	BROWN	DWC-24-01-300	BROWN	DWC-24-01-300	BROWN	DWC-16-01-300	COAX	CCS-174525-01-CC	BROWN	DWC-24-01-300	BROWN	DWC-24-01-300
02	RED	DWC-24-02-300	RED	DWC-24-02-300	RED	DWC-16-02-300	COAX		RED	DWC-24-02-300	RED	DWC-24-02-300
03	ORANGE	DWC-24-03-300	ORANGE	DWC-24-03-300	ORANGE	DWC-16-03-300	COAX		ORANGE	DWC-24-03-300	ORANGE	DWC-24-03-300
04	YELLOW	DWC-24-04-300	YELLOW	DWC-24-04-300	YELLOW	DWC-16-04-300	COAX		YELLOW	DWC-24-04-300	YELLOW	DWC-24-04-300
05	GREEN	DWC-24-05-300	GREEN	DWC-24-05-300	GREEN	DWC-16-05-300	COAX		GREEN	DWC-24-05-300	GREEN	DWC-24-05-300
06	DARK BLUE	DWC-24-06-300	DARK BLUE	DWC-24-06-300	DARK BLUE	DWC-16-06-300	COAX		DARK BLUE	DWC-24-06-300	DARK BLUE	DWC-24-06-300
07	VIOLET	DWC-24-07-300	VIOLET	DWC-24-07-300	VIOLET	DWC-16-07-300			VIOLET	DWC-24-07-300	VIOLET	DWC-24-07-300
08	GRAY	DWC-24-08-300	GRAY	DWC-24-08-300	GRAY	DWC-16-08-300			GRAY	DWC-24-08-300	GRAY	DWC-24-08-300
09	WHITE	DWC-24-09-300	WHITE	DWC-24-09-300					WHITE	DWC-24-09-300	WHITE	DWC-24-09-300
10	BLACK	DWC-24-10-300	BLACK	DWC-24-10-300					BLACK	DWC-24-10-300	BLACK	DWC-24-10-300
11	GREEN / BLACK	DWC-24-11-300	GREEN / BLACK	DWC-24-11-300					GREEN / BLACK	DWC-24-11-300	GREEN / BLACK	DWC-24-11-300
12	TAN	DWC-24-12-300	TAN	DWC-24-12-300					TAN	DWC-24-12-300	TAN	DWC-24-12-300
13	DARK BLUE / YELLOW	DWC-24-31-300	DARK BLUE / YELLOW	DWC-24-31-300					DARK BLUE / YELLOW	DWC-24-31-300	COAX	CCS-174525-01-CC
14	PINK	DWC-24-14-300	PINK	DWC-24-14-300				PINK	DWC-24-14-300	COAX		
15	BROWN / WHITE	DWC-24-15-300	BROWN / WHITE	DWC-24-15-300				BROWN / WHITE	DWC-24-15-300	COAX		
16	RED / WHITE	DWC-24-16-300	RED / WHITE	DWC-24-16-300				RED / WHITE	DWC-24-16-300	COAX		
17	ORANGE / WHITE	DWC-24-17-300	ORANGE / WHITE	DWC-24-17-300				ORANGE / WHITE	DWC-16-17-300			
18	YELLOW / WHITE	DWC-24-18-300	YELLOW / WHITE	DWC-24-18-300				YELLOW / WHITE	DWC-16-18-300			
19	GREEN / WHITE	DWC-24-19-300	GREEN / WHITE	DWC-24-19-300				GREEN / WHITE	DWC-16-19-300			
20	DARK BLUE / WHITE	DWC-24-20-300	DARK BLUE / WHITE	DWC-24-20-300	NA				DARK BLUE / WHITE	DWC-16-20-300		
21	VIOLET / WHITE	DWC-24-21-300										
22	GRAY / WHITE	DWC-24-22-300										
23	WHITE / BLACK	DWC-24-23-300										
24	BLACK / WHITE	DWC-24-24-300										
25	GREEN / YELLOW	DWC-24-25-300										
26	TAN / WHITE	DWC-24-26-300	NA						NA			
27	DARK BLUE / PINK	DWC-24-27-300										
28	PINK / WHITE	DWC-24-28-300										
29	BROWN / BLACK	DWC-24-29-300										
30	RED / BLACK	DWC-24-30-300										

PROPRIETARY NOTE
 THIS DOCUMENT CONTAINS CONFIDENTIAL AND PROPRIETARY INFORMATION AND ALL DESIGN, MANUFACTURING, REPRODUCTION, USE, PATENT RIGHTS AND SALES RIGHTS ARE EXPRESSLY RESERVED BY SAMTEC, INC. THIS DOCUMENT SHALL NOT BE DISCLOSED, IN WHOLE OR PART, TO ANY UNAUTHORIZED PERSON OR ENTITY NOR REPRODUCED, TRANSFERRED OR INCORPORATED IN ANY OTHER PROJECT IN ANY MANNER WITHOUT THE EXPRESS WRITTEN CONSENT OF SAMTEC, INC.

DO NOT SCALE DRAWING
 SHEET SCALE: 1:1



520 PARK EAST BLVD, NEW ALBANY, IN 47150
 PHONE: 812-944-6733 FAX: 812-948-5047
 e-Mail info@SAMTEC.com code 55322

DESCRIPTION: M22 CABLE ASSEMBLY
 DWG. NO. ACR-22-XX-X-XX.XX-X-XX-P-X
 BY: CLAY W 9/8/2010 SHEET 5 OF 8

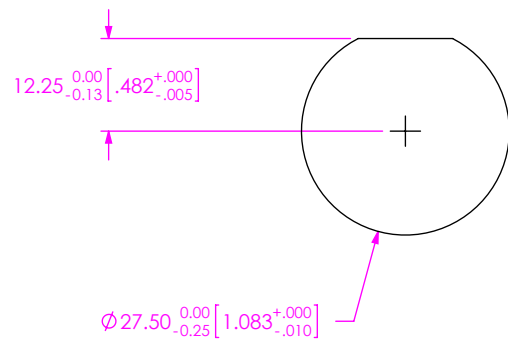

RECOMMENDED PANEL OPENING
(SEE NOTE 8)

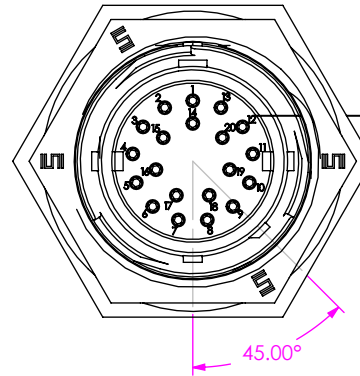

-1
(ORANGE KEY RING)

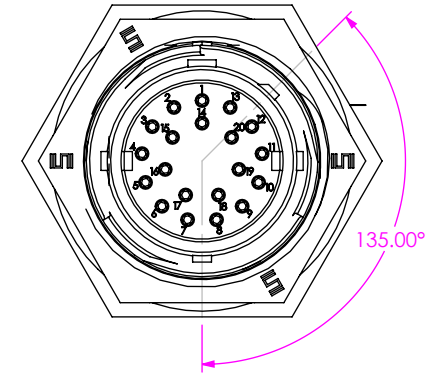

-2
(GREEN KEY RING)

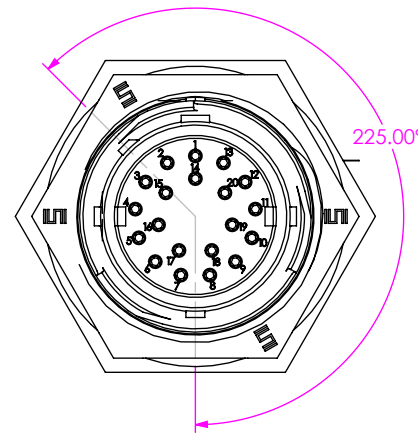

-3
(BLUE KEY RING)

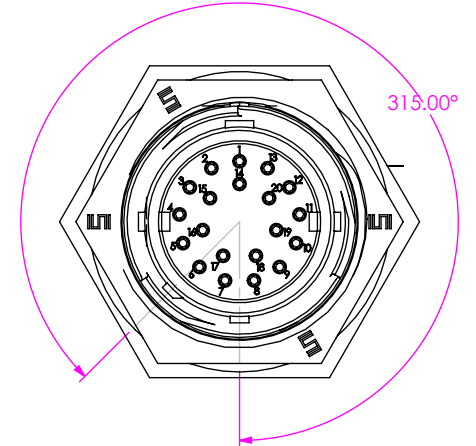

-4
(YELLOW KEY RING)

KEYING FEATURE
(SEE NOTE 4)

PROPRIETARY NOTE
THIS DOCUMENT CONTAINS CONFIDENTIAL AND PROPRIETARY INFORMATION AND ALL DESIGN, MANUFACTURING, REPRODUCTION, USE, PATENT RIGHTS AND SALES RIGHTS ARE EXPRESSLY RESERVED BY SAMTEC, INC. THIS DOCUMENT SHALL NOT BE DISCLOSED, IN WHOLE OR PART, TO ANY UNAUTHORIZED PERSON OR ENTITY NOR REPRODUCED, TRANSFERRED OR INCORPORATED IN ANY OTHER PROJECT IN ANY MANNER WITHOUT THE EXPRESS WRITTEN CONSENT OF SAMTEC, INC.

DO NOT SCALE DRAWING
SHEET SCALE: 1:1

samtec
520 PARK EAST BLVD, NEW ALBANY, IN 47150
PHONE: 812-944-6733 FAX: 812-948-5047
e-Mail info@SAMTEC.com code 55322

DESCRIPTION:	M22 CABLE ASSEMBLY
DWG. NO.	ACR-22-XX-X-XX.XX-X-XX-P-X
BY: CLAY W	9/8/2010
SHEET 6 OF 8	

5.50±0.25 [.217±.010]

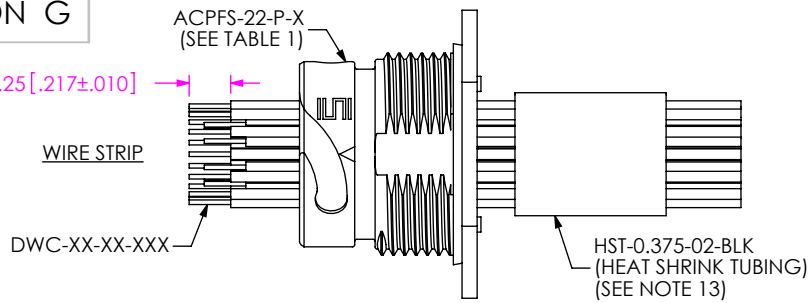

CCA-316 COAX (SEE NOTE 15)

COAX STRIP

REFERENCE AC-P-C-X-ST-CA1 & AC-J-C-X-ST-CA1 PRINTS FOR COAX STRIP DIMENSIONS

ACPFS-22-P-X (SEE TABLE 1)

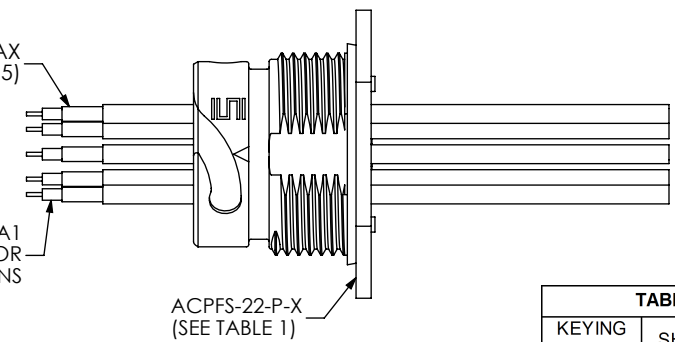

KEYING FEATURE	SHELL PART #
-1	ACPFS-22-P-1
-2	ACPFS-22-P-2
-3	ACPFS-22-P-3
-4	ACPFS-22-P-4

IN-PROCESS 1

FEED CABLES FROM END 2 DISCRETE CABLE ASSEMBLY THROUGH HST-0.375-02-BLK & ACPFS-22-P-X, STRIP CABLES TO DIMENSIONS SHOWN AND TIN INNER CONDUCTORS. FOR -BC OPTION, FEED DWC/COAX & STRIP TO DIMENSIONS SHOWN

SUB-ACTHB-22-X-XX (SEE TABLE 3)

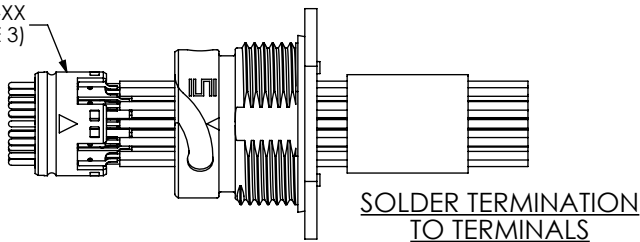

ON LEADSTYLE -06 TERMINATE & INSERT COAX PLUGS/JACKS BEFORE SOLDERING REMAINING WIRES

SUB-ACSHB-22-X-XX (SEE TABLE 3)

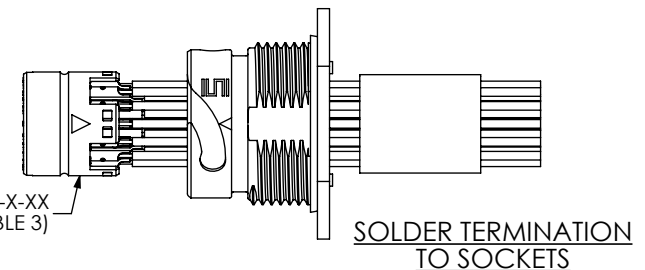

11.80 [.465] REF

SUB-ACTHB-22-X-XX OR ACTHB-22-X (SEE TABLE 3)

3.20^{+0.25}_{-0.13} [.126^{+0.010}_{-.005}]

COAX PLUG INSERTION
AFTER INSERTION, PUSH COAX PLUG INTO CORE UNTIL RETENTION BEAMS ENGAGE AND LOCK IT IN PLACE

ON LEADSTYLES -01, -02, -03, -05, & -06 SOLDER INNER RING OF TERMINALS/SOCKETS FIRST AND THEN OUTER RING

15.80 [.622] REF

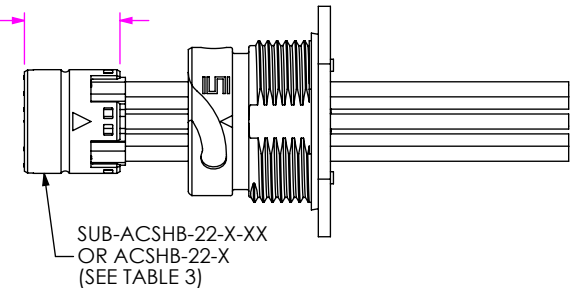

COAX JACK INSERTION
AFTER TERMINATION, PUSH COAX JACK INTO CORE UNTIL RETENTION BEAMS ENGAGE AND LOCK IT IN PLACE

IN-PROCESS 2

TERMINATE WIRES/COAX TO TERMINALS/SOCKETS (SEE AC-P-C-X-ST-CA1 & AC-J-C-X-ST-CA1 PRINTS FOR COAX TERMINATION)

TABLE 3

LEAD STYLES	END1/END 2	PLATING		COAX PLUG/JACK PART #	
		-G	-H	AC-X-C-H-ST-CA1	QTY
-01	-T	SUB-ACTHB-22-G-01	SUB-ACTHB-22-H-01	NA	
-02	-T	SUB-ACTHB-22-G-02	SUB-ACTHB-22-H-02	NA	
-03	-T	SUB-ACTHB-22-G-03	SUB-ACTHB-22-H-03	NA	
-04	-T	ACTHB-22-6	ACTHB-22-6	AC-P-C-H-ST-CA1	6
-05	-T	SUB-ACTHB-22-G-05	SUB-ACTHB-22-H-05	NA	
-06	-T	SUB-ACTHB-22-G-06	SUB-ACTHB-22-H-06	AC-P-C-H-ST-CA1	4
-01	-S	SUB-ACSHB-22-G-01	SUB-ACSHB-22-H-01	NA	
-02	-S	SUB-ACSHB-22-G-02	SUB-ACSHB-22-H-02	NA	
-03	-S	SUB-ACSHB-22-G-03	SUB-ACSHB-22-H-03	NA	
-04	-S	ACSHB-22-6	ACSHB-22-6	AC-J-C-H-ST-CA1	6
-05	-S	SUB-ACSHB-22-G-05	SUB-ACSHB-22-H-05	NA	
-06	-S	SUB-ACSHB-22-G-06	SUB-ACSHB-22-H-06	AC-J-C-H-ST-CA1	4

F:\DWG\MISC\MKTG\ACR-22-XX-X-XX-XX-X-XX-P-X-MKT.SLDDRW

PROPRIETARY NOTE

THIS DOCUMENT CONTAINS CONFIDENTIAL AND PROPRIETARY INFORMATION AND ALL DESIGN, MANUFACTURING, REPRODUCTION, USE, PATENT RIGHTS AND SALES RIGHTS ARE EXPRESSLY RESERVED BY SAMTEC, INC. THIS DOCUMENT SHALL NOT BE DISCLOSED, IN WHOLE OR PART, TO ANY UNAUTHORIZED PERSON OR ENTITY NOR REPRODUCED, TRANSFERRED OR INCORPORATED IN ANY OTHER PROJECT IN ANY MANNER WITHOUT THE EXPRESS WRITTEN CONSENT OF SAMTEC, INC.

DO NOT SCALE DRAWING

SHEET SCALE: 1:1



520 PARK EAST BLVD, NEW ALBANY, IN 47150
PHONE: 812-944-6733 FAX: 812-948-5047
e-Mail info@SAMTEC.com code 55322

DESCRIPTION:

M22 CABLE ASSEMBLY

DWG. NO.

ACR-22-XX-X-XX.XX-X-XX-P-X

BY: CLAY W

9/8/2010

SHEET 7 OF 8

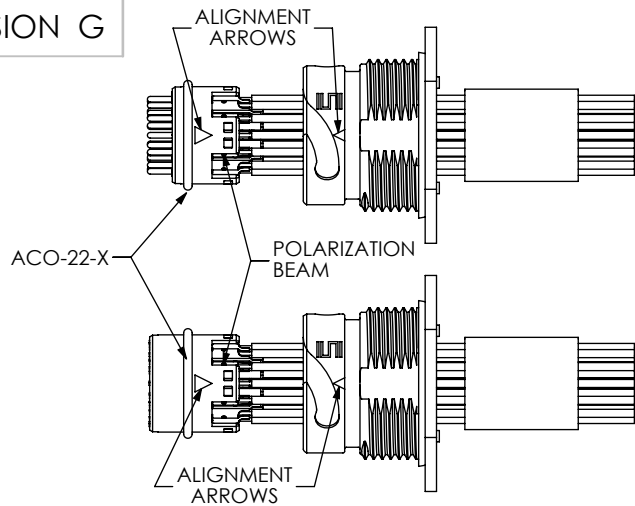

IN-PROCESS 3
 PUSH ACO-22-1 ORING ONTO SUB-ACTHB-22-X-X OR SUB-ACSHB-22-X-X SUB-ASSEMBLIES

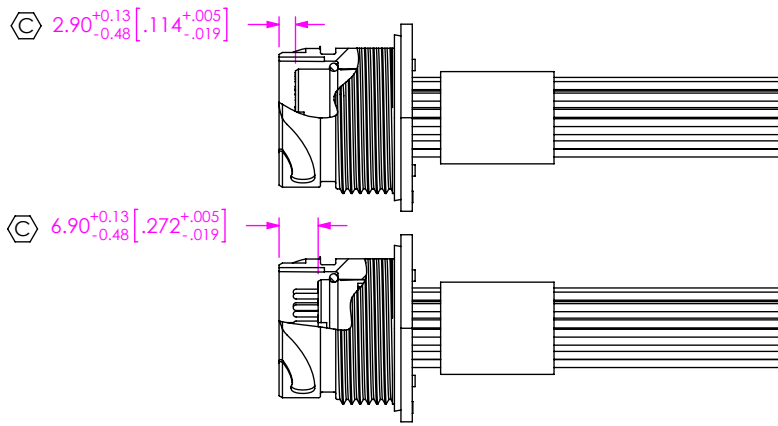

IN-PROCESS 4
 WHILE MAKING SURE ALIGNMENT ARROWS LINE UP TO AID POLARIZATION BEAM ENGAGEMENT, INSERT SUB-ACXHB-22-X SUB-ASSEMBLY INTO ACPFS-22-P-X PANEL SHELL UNTIL SNAP LOCKS ENGAGE

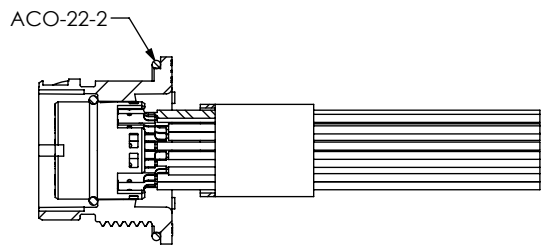

IN-PROCESS 5
 INSERT ACO-22-2 WHERE SHOWN

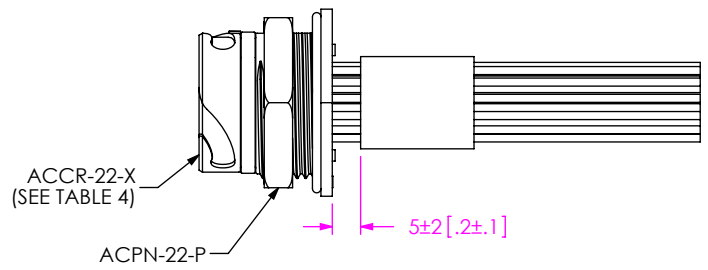

IN-PROCESS 6
 THREAD ACPN-22-P ONTO ACPFS-22-P-X
 STRETCH ACCR-22-X OVER ACPFS-22-P-X
 UNTIL IT SEATS IN GROOVE. ACTIVATE HEAT SHRINK TUBING.

TABLE 4	
KEYING FEATURE	ACCR-22-X
-1 (ORANGE)	ACCR-22-1
-2 (GREEN)	ACCR-22-2
-3 (BLUE)	ACCR-22-3
-4 (YELLOW)	ACCR-22-4

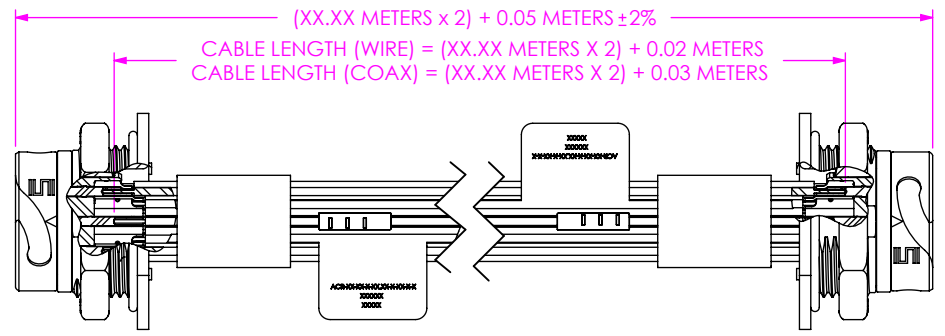

IN-PROCESS 7
 (-BC OPTION ONLY)
 BUILD DOUBLE-ENDED INITIALLY FOR E-TEST,
 APPLY LABEL-ET & HDRL-11 TO BOTH ENDS,
 AND CUT CABLE IN HALF

PROPRIETARY NOTE
 THIS DOCUMENT CONTAINS CONFIDENTIAL AND PROPRIETARY INFORMATION AND ALL DESIGN, MANUFACTURING, REPRODUCTION, USE, PATENT RIGHTS AND SALES RIGHTS ARE EXPRESSLY RESERVED BY SAMTEC, INC. THIS DOCUMENT SHALL NOT BE DISCLOSED, IN WHOLE OR PART, TO ANY UNAUTHORIZED PERSON OR ENTITY NOR REPRODUCED, TRANSFERRED OR INCORPORATED IN ANY OTHER PROJECT IN ANY MANNER WITHOUT THE EXPRESS WRITTEN CONSENT OF SAMTEC, INC.

DO NOT SCALE DRAWING

SHEET SCALE: 1:1

520 PARK EAST BLVD, NEW ALBANY, IN 47150
 PHONE: 812-944-6733 FAX: 812-948-5047
 e-Mail: info@SAMTEC.com code 55322

DESCRIPTION: M22 CABLE ASSEMBLY

DWG. NO. ACR-22-XX-X-XX.XX-X-XX-P-X

BY: CLAY W 9/8/2010 SHEET 8 OF 8