

DO NOT
SCALE FROM
THIS PRINT

Pb THIS PRODUCT MANUFACTURED
WITH LEAD-FREE PROCESSING

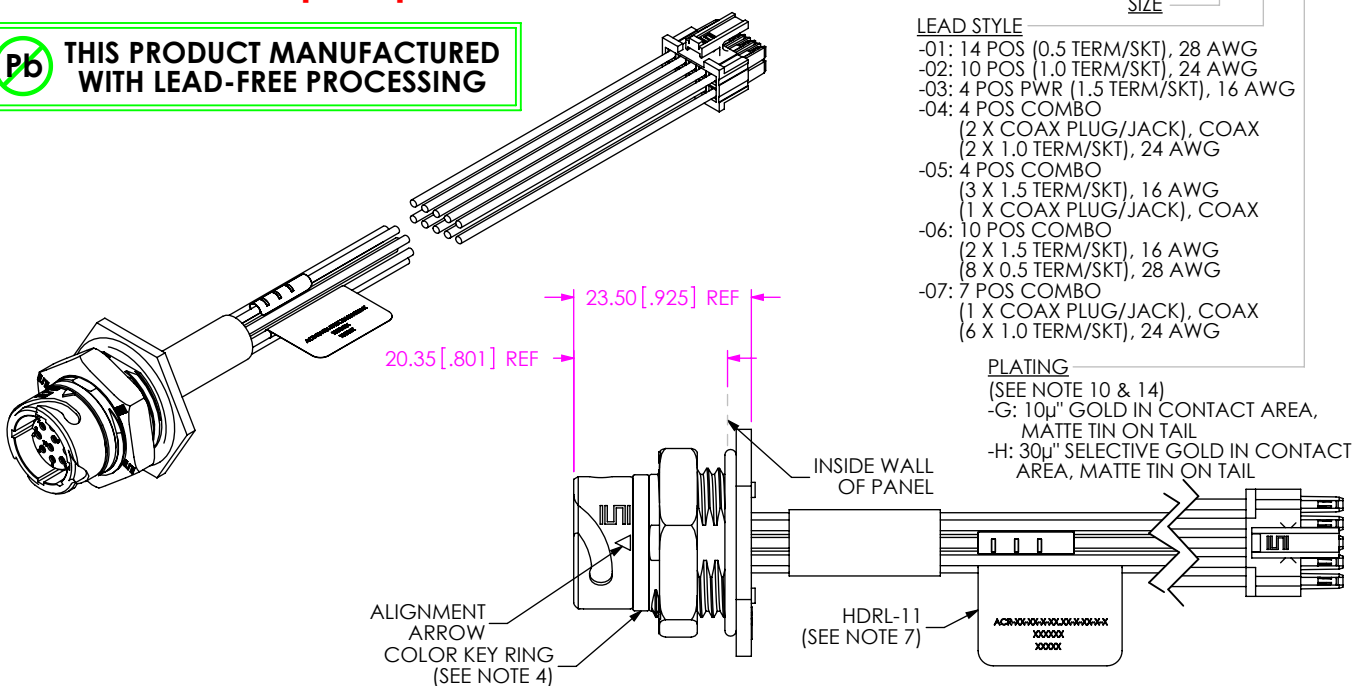

- LEAD STYLE**
- 01: 14 POS (0.5 TERM/SKT), 28 AWG
 - 02: 10 POS (1.0 TERM/SKT), 24 AWG
 - 03: 4 POS PWR (1.5 TERM/SKT), 16 AWG
 - 04: 4 POS COMBO
(2 X COAX PLUG/JACK), COAX
(2 X 1.0 TERM/SKT), 24 AWG
 - 05: 4 POS COMBO
(3 X 1.5 TERM/SKT), 16 AWG
(1 X COAX PLUG/JACK), COAX
 - 06: 10 POS COMBO
(2 X 1.5 TERM/SKT), 16 AWG
(8 X 0.5 TERM/SKT), 28 AWG
 - 07: 7 POS COMBO
(1 X COAX PLUG/JACK), COAX
(6 X 1.0 TERM/SKT), 24 AWG

- KEYING FEATURE**
(SEE NOTE 4)
- 1: ORANGE
 - 2: GREEN
 - 3: BLUE
 - 4: YELLOW
- STYLE**
-P: PLASTIC
- END 2**
- BC: BLUNT CUT
 - S1: CONNECTOR
(DETERMINED BY
LEAD STYLE)

- PLATING**
(SEE NOTE 10 & 14)
- G: 10µ" GOLD IN CONTACT AREA,
MATTE TIN ON TAIL
 - H: 30µ" SELECTIVE GOLD IN CONTACT
AREA, MATTE TIN ON TAIL

ASSEMBLED LENGTH
XX.XX (IN METERS)
(00.20 METER MIN TO 50.00 METER MAX)

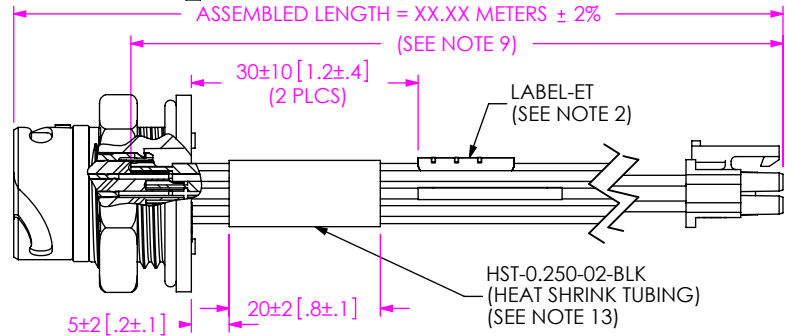
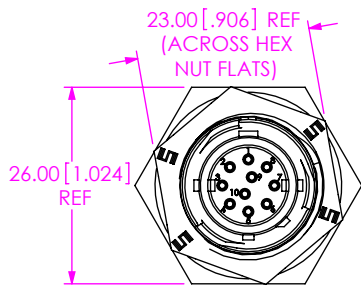

NOTES:

1. Ⓢ REPRESENTS A CRITICAL DIMENSION.
2. ASSEMBLY TO BE 100% TESTED FOR CONTINUITY, ISOLATION, & HI-POT AT 300V. (1) LABEL-ET TO BE APPLIED AFTER FINAL ELECTRICAL TEST.
3. ASSEMBLIES TO BE BULK PACKAGED.
4. KEYING FEATURE DETERMINES COLOR OF KEY RING AND DUSTCAP LANYARD IF APPLICABLE.
5. SIGNAL MAPPING IS 1 TO 1, 2 TO 2, 3 TO 3, etc..
6. REFER TO DCA-ACR-16-P-X PRINT FOR DUST CAP.
7. PLACE HDRL-11 (LABEL) ON CABLE WHERE SHOWN. LABEL TO CONTAIN
LINE 1 - PART NUMBER "ACR-16-XX-X-XX.XX-X-XX-P-X"
LINE 2 - SHOP ORDER NUMBER "XXXXXX"
LINE 3 - DATE CODE "XXXXX"
8. PANEL THICKNESS RANGE: 0.80[0.031] - 5.20[0.205].
9. FOR END 2 CABLE LENGTH, REFERENCE END 2 OPTIONS ON SHEET 4.
10. END 2 CONNECTOR PLATING: SFSD, MMSD & MPSS: 10µ" GOLD IN CONTACT AREA
RF316: 30µ" GOLD CENTER CONTACT
3µ" GOLD OUTER CONTACT
11. NOTE DELETED.
12. WHEN MOUNTING PRODUCT TO PANEL TORQUE ACPN-16-P TO 15 IN-LBS.
13. APPLY HEAT SHRINK TUBING TO -01, -02, -06, & -07 LEAD STYLES.
14. PLATING CALLOUTS APPLY TO END 1 TERMINALS & SOCKETS ONLY. COAX PLUGS/JACKS HAVE -H PLATING ON INNER TERMINALS/SOCKETS & -F PLATING ON OUTER SHELLS.
15. MINIMUM BEND RADIUS FOR COAX CABLE IS 25.4[1.00].

FIG 1
ACR-16-02-X-XX.XX-S-S1-P-1

UNLESS OTHERWISE SPECIFIED,
DIMENSIONS ARE IN MILLIMETERS.

TOLERANCES ARE:

DECIMALS	ANGLES
X.X: ±0.3 [.01]	2°
X.XX: ±0.13 [.005]	
X.XXX: ±0.051 [.0020]	

PROPRIETARY NOTE

THIS DOCUMENT CONTAINS CONFIDENTIAL AND PROPRIETARY INFORMATION AND ALL DESIGN, MANUFACTURING, REPRODUCTION, USE, PATENT RIGHTS AND SALES RIGHTS ARE EXPRESSLY RESERVED BY SAMTEC, INC. THIS DOCUMENT SHALL NOT BE DISCLOSED, IN WHOLE OR PART, TO ANY UNAUTHORIZED PERSON OR ENTITY NOR REPRODUCED, TRANSFERRED OR INCORPORATED IN ANY OTHER PROJECT IN ANY MANNER WITHOUT THE EXPRESS WRITTEN CONSENT OF SAMTEC, INC.



520 PARK EAST BLVD, NEW ALBANY, IN 47150
PHONE: 812-944-6733 FAX: 812-948-5047
e-Mail info@SAMTEC.com code 53322

MATERIAL: DO NOT SCALE DRAWING SHEET SCALE: 1:1
SHELL: NYLON, COLOR: BLACK
INSULATOR: PBT
TERMINALS: BRASS
CONTACTS: BRASS/BeCu

DESCRIPTION: M16 CABLE ASSEMBLY

DWG. NO. ACR-16-XX-X-XX.XX-X-XX-P-X

BY: D.SCHMELZ 04/27/2010 SHEET 1 OF 8

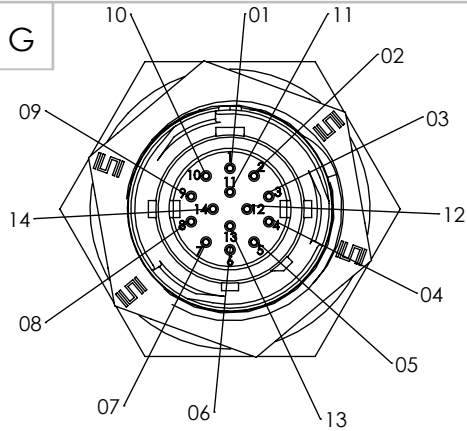

-01: 14 POS
(\varnothing 0.5 TERMINALS)

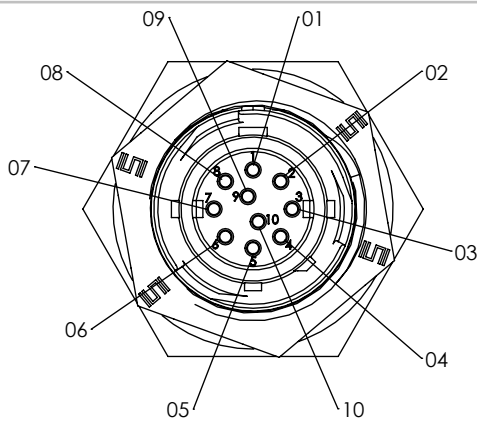

-02: 10 POS
(\varnothing 1.0 TERMINALS)

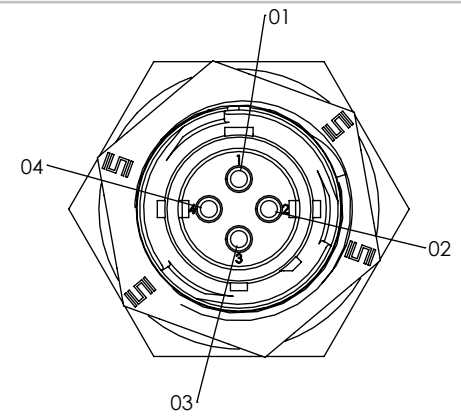

-03: 4 POS
(\varnothing 1.5 TERMINALS)

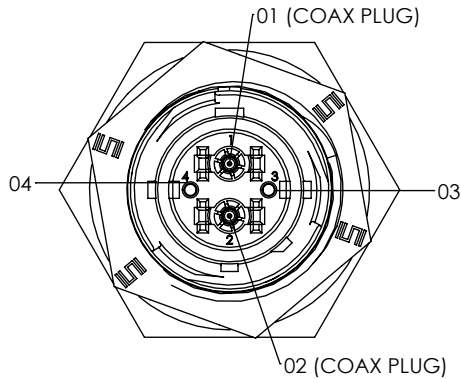

-04: 4 POS COMBO
(2 X COAX PLUGS)
(2 X \varnothing 1.0 TERMINALS)

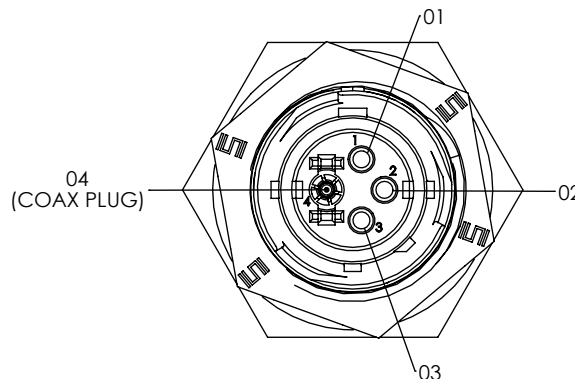

-05: 4 POS COMBO
(3 X \varnothing 1.5 TERMINALS)
(1 X COAX PLUG)

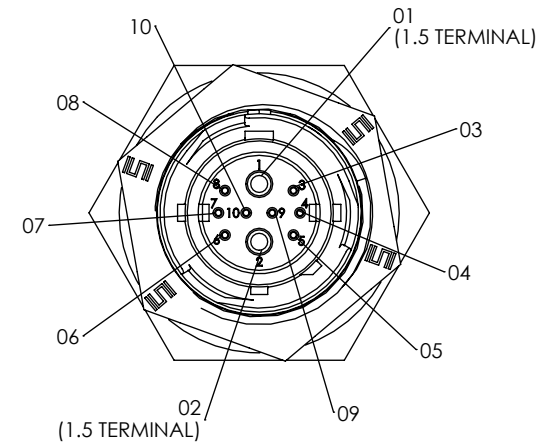

-06: 10 POS COMBO
(2 X \varnothing 1.5 TERMINALS)
(8 X \varnothing 0.5 TERMINALS)

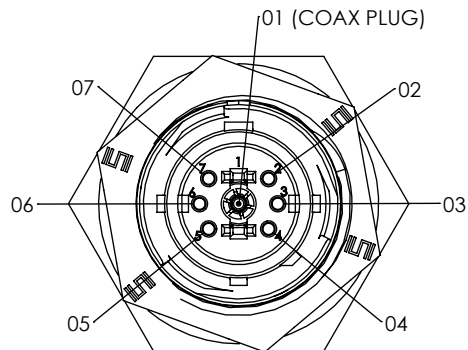

-07: 7 POS COMBO
(1 X COAX PLUG)
(6 X \varnothing 1.0 TERMINALS)

-T END OPTIONS

F:\DWG\MISC\MKTG\ACR-16-XX-X-XX.XX-X-XX-P-X-MKT.SLDDRW

PROPRIETARY NOTE
THIS DOCUMENT CONTAINS CONFIDENTIAL AND PROPRIETARY INFORMATION AND ALL DESIGN, MANUFACTURING, REPRODUCTION, USE, PATENT RIGHTS AND SALES RIGHTS ARE EXPRESSLY RESERVED BY SAMTEC, INC. THIS DOCUMENT SHALL NOT BE DISCLOSED, IN WHOLE OR PART, TO ANY UNAUTHORIZED PERSON OR ENTITY NOR REPRODUCED, TRANSFERRED OR INCORPORATED IN ANY OTHER PROJECT IN ANY MANNER WITHOUT THE EXPRESS WRITTEN CONSENT OF SAMTEC, INC.

DO NOT SCALE DRAWING

SHEET SCALE: 1.5:1



520 PARK EAST BLVD, NEW ALBANY, IN 47150
PHONE: 812-944-6733 FAX: 812-948-5047
e-Mail info@SAMTEC.com code 55322

DESCRIPTION:
M16 CABLE ASSEMBLY

DWG. NO.
ACR-16-XX-X-XX.XX-X-XX-P-X

BY: D.SCHMELZ 04/27/2010 SHEET 2 OF 8

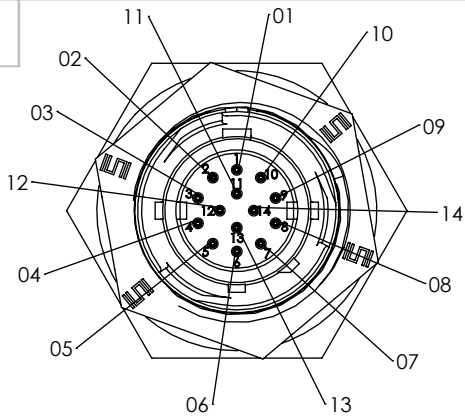

-01: 14 POS
(Ø0.5 SOCKETS)

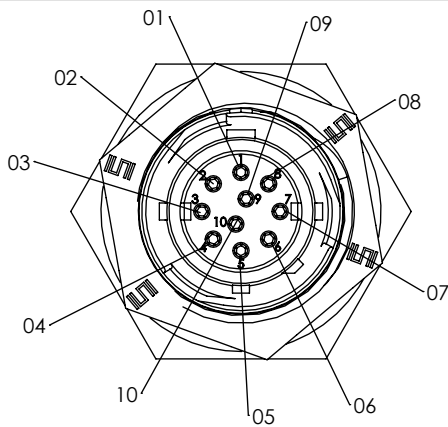

-02: 10 POS
(Ø1.0 SOCKETS)

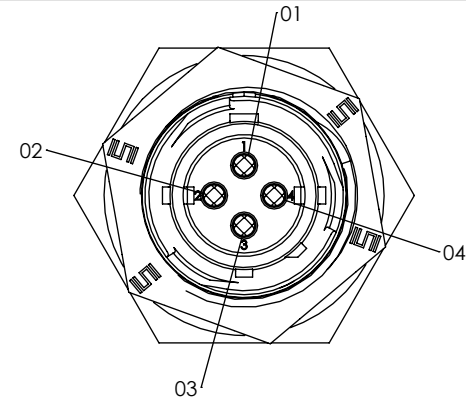

-03: 4 POS
(Ø1.5 SOCKETS)

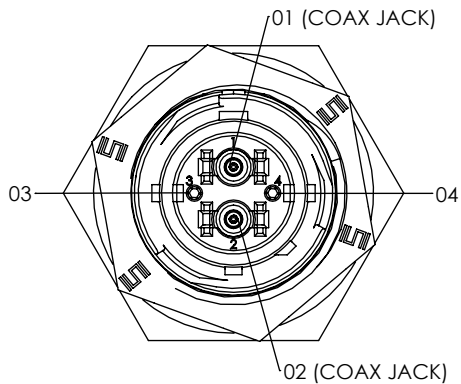

-04: 4 POS COMBO
(2 X COAX JACKS)
(2 X Ø1.0 SOCKETS)

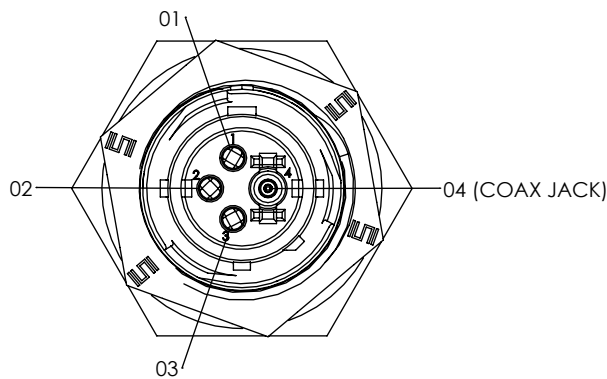

-05: 4 POS COMBO
(3 X Ø1.5 SOCKETS)
(1 X COAX JACK)

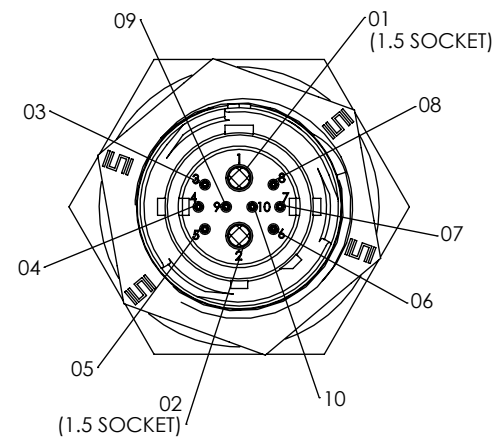

-06: 10 POS COMBO
(2 X Ø1.5 SOCKETS)
(8 X Ø0.5 SOCKETS)

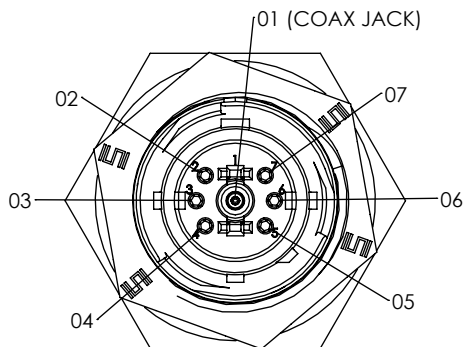

-07: 7 POS COMBO
(1 X COAX JACK)
(6 X Ø1.0 SOCKETS)

-S END OPTIONS

PROPRIETARY NOTE
THIS DOCUMENT CONTAINS CONFIDENTIAL AND PROPRIETARY INFORMATION AND ALL DESIGN, MANUFACTURING, REPRODUCTION, USE, PATENT RIGHTS AND SALES RIGHTS ARE EXPRESSLY RESERVED BY SAMTEC, INC. THIS DOCUMENT SHALL NOT BE DISCLOSED, IN WHOLE OR PART, TO ANY UNAUTHORIZED PERSON OR ENTITY NOR REPRODUCED, TRANSFERRED OR INCORPORATED IN ANY OTHER PROJECT IN ANY MANNER WITHOUT THE EXPRESS WRITTEN CONSENT OF SAMTEC, INC.

DO NOT SCALE DRAWING

SHEET SCALE: 1.5:1



520 PARK EAST BLVD, NEW ALBANY, IN 47150
PHONE: 812-944-6733 FAX: 812-948-5047
e-Mail info@SAMTEC.com code 55322

DESCRIPTION: M16 CABLE ASSEMBLY

DWG. NO. ACR-16-XX-X-XX.XX-X-XX-P-X

BY: D.SCHMELZ 04/27/2010 SHEET 3 OF 8

REVISION G

END 2 OPTIONS

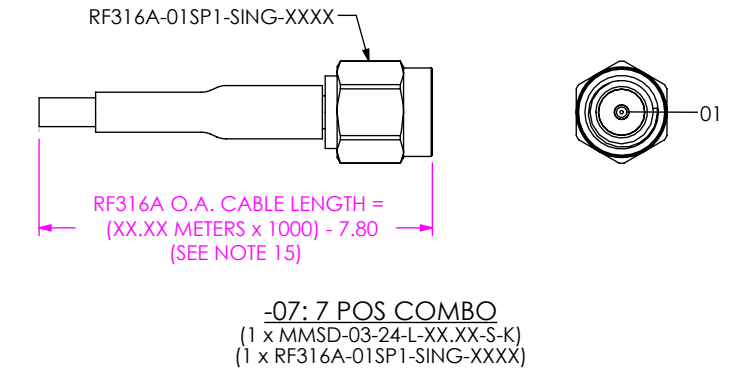
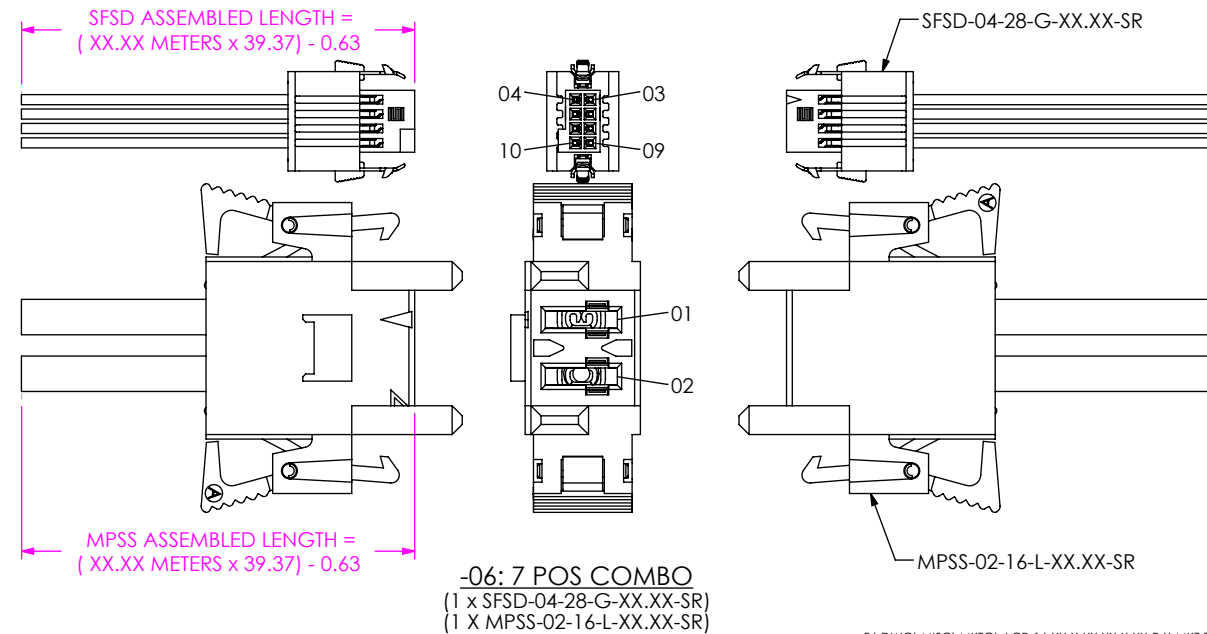
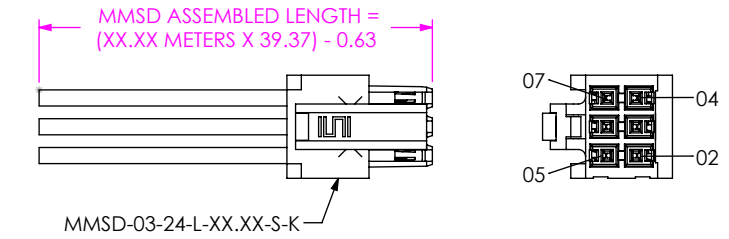
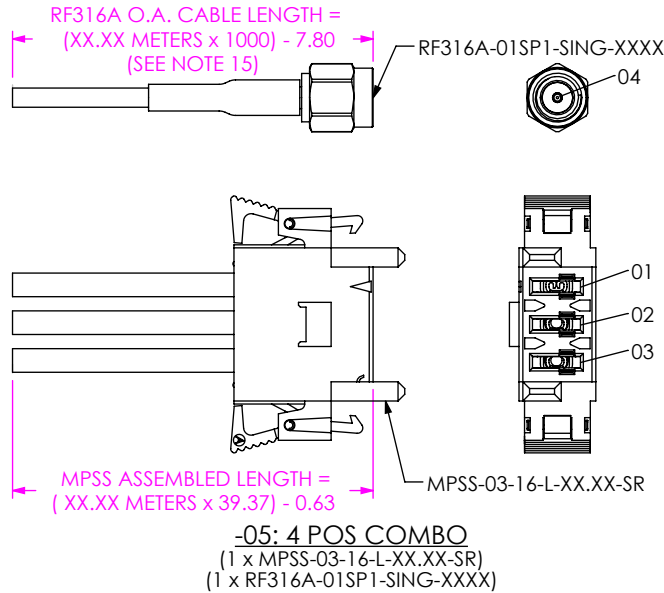
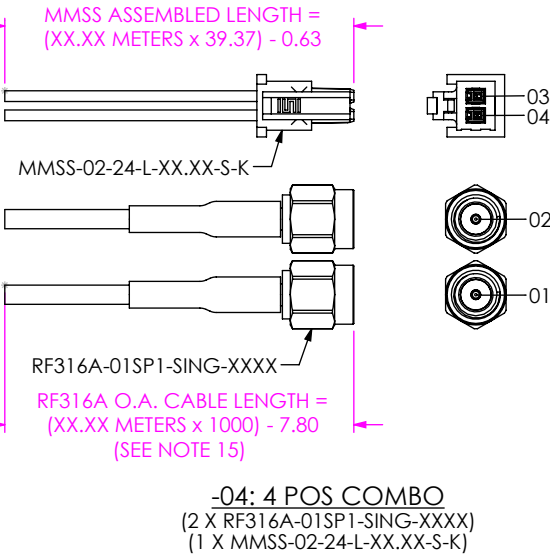
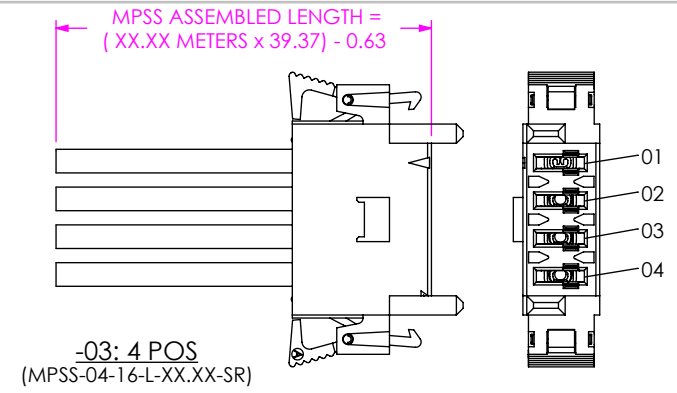
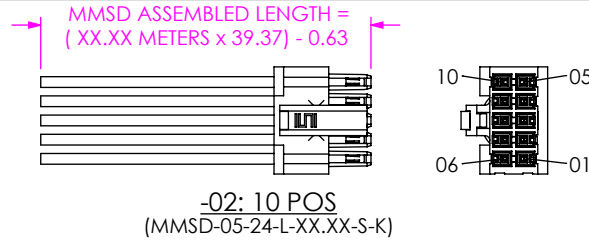
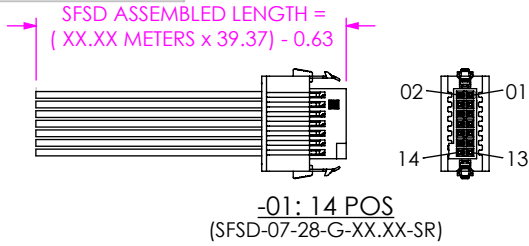

PROPRIETARY NOTE
THIS DOCUMENT CONTAINS CONFIDENTIAL AND PROPRIETARY INFORMATION AND ALL DESIGN, MANUFACTURING, REPRODUCTION, USE, PATENT RIGHTS AND SALES RIGHTS ARE EXPRESSLY RESERVED BY SAMTEC, INC. THIS DOCUMENT SHALL NOT BE DISCLOSED, IN WHOLE OR PART, TO ANY UNAUTHORIZED PERSON OR ENTITY NOR REPRODUCED, TRANSFERRED OR INCORPORATED IN ANY OTHER PROJECT IN ANY MANNER WITHOUT THE EXPRESS WRITTEN CONSENT OF SAMTEC, INC.

DO NOT SCALE DRAWING

SHEET SCALE: 1:1



520 PARK EAST BLVD, NEW ALBANY, IN 47150
PHONE: 812-944-6733 FAX: 812-948-5047
e-Mail info@SAMTEC.com code 55322

DESCRIPTION:
M16 CABLE ASSEMBLY

DWG. NO.
ACR-16-XX-X-XX.XX-X-XX-P-X

BY: D.SCHMELZ 04/27/2010 SHEET 4 OF 8

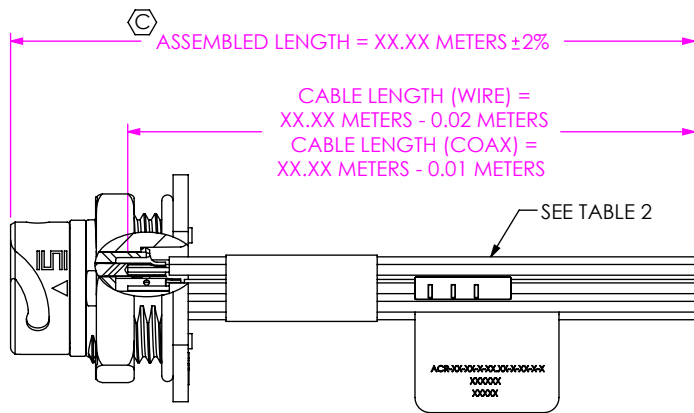

-BC END OPTION
 (BUILD DOUBLE-ENDED INITIALLY FOR E-TEST)
 (SEE TABLE 2 FOR DWC CALLOUTS/SIGNAL MAPPING)
 (SEE IN-PROCESS 7)

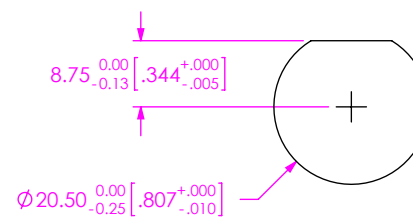

RECOMMENDED PANEL OPENING
 (SEE NOTE 8 & 12)

TABLE 2
 LEAD STYLE

POSITION	-01		-02		-03		-04		-05		-06		-07	
	COLOR	CABLE PART #	COLOR	CABLE PART #	COLOR	CABLE PART #	COLOR	CABLE PART #	COLOR	CABLE PART #	COLOR	CABLE PART #	COLOR	CABLE PART #
01	BROWN	DWC-28H-01-300	BROWN	DWC-24-01-300	BROWN	DWC-16-01-300	COAX	CCS-174525-01-CC	BROWN	DWC-16-01-300	BROWN	DWC-16-01-300	COAX	CCS-174525-01-CC
02	RED	DWC-28H-02-300	RED	DWC-24-02-300	RED	DWC-16-02-300	COAX	CCS-174525-01-CC	RED	DWC-16-02-300	RED	DWC-16-02-300	RED	DWC-24-02-300
03	ORANGE	DWC-28H-03-300	ORANGE	DWC-24-03-300	ORANGE	DWC-16-03-300	ORANGE	DWC-24-03-300	ORANGE	DWC-16-03-300	ORANGE	DWC-28H-03-300	ORANGE	DWC-24-03-300
04	YELLOW	DWC-28H-04-300	YELLOW	DWC-24-04-300	YELLOW	DWC-16-04-300	YELLOW	DWC-24-04-300	COAX	CCS-174525-01-CC	YELLOW	DWC-28H-04-300	YELLOW	DWC-24-04-300
05	GREEN	DWC-28H-05-300	GREEN	DWC-24-05-300							GREEN	DWC-28H-05-300	GREEN	DWC-24-05-300
06	DARK BLUE	DWC-28H-06-300	DARK BLUE	DWC-24-06-300							DARK BLUE	DWC-28H-06-300	DARK BLUE	DWC-24-06-300
07	VIOLET	DWC-28H-07-300	VIOLET	DWC-24-07-300							VIOLET	DWC-28H-07-300	VIOLET	DWC-24-07-300
08	GRAY	DWC-28H-08-300	GRAY	DWC-24-08-300							GRAY	DWC-28H-08-300		
09	WHITE	DWC-28H-09-300	WHITE	DWC-24-09-300							WHITE	DWC-28H-09-300		
10	BLACK	DWC-28H-10-300	BLACK	DWC-24-10-300	NA		NA		NA		BLACK	DWC-28H-10-300		
11	GREEN/BLACK	DWC-28H-11-300												
12	TAN	DWC-28H-12-300	NA											
13	DARK BLUE/YELLOW	DWC-28H-31-300												
14	PINK	DWC-28H-14-300												

PROPRIETARY NOTE
 THIS DOCUMENT CONTAINS CONFIDENTIAL AND PROPRIETARY INFORMATION AND ALL DESIGN, MANUFACTURING, REPRODUCTION, USE, PATENT RIGHTS AND SALES RIGHTS ARE EXPRESSLY RESERVED BY SAMTEC, INC. THIS DOCUMENT SHALL NOT BE DISCLOSED, IN WHOLE OR PART, TO ANY UNAUTHORIZED PERSON OR ENTITY NOR REPRODUCED, TRANSFERRED OR INCORPORATED IN ANY OTHER PROJECT IN ANY MANNER WITHOUT THE EXPRESS WRITTEN CONSENT OF SAMTEC, INC.

DO NOT SCALE DRAWING

SHEET SCALE: 1:1



520 PARK EAST BLVD, NEW ALBANY, IN 47150
 PHONE: 812-944-6733 FAX: 812-948-5047
 e-Mail info@SAMTEC.com code 55322

DESCRIPTION:
 M16 CABLE ASSEMBLY

DWG. NO.
ACR-16-XX-X-XX.XX-X-XX-P-X

BY: D.SCHMELZ 04/27/2010 SHEET 5 OF 8

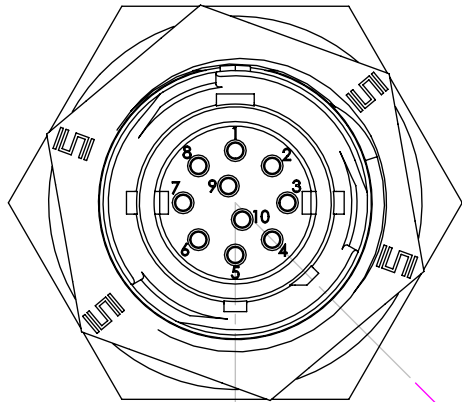

-1
(ORANGE KEY RING)

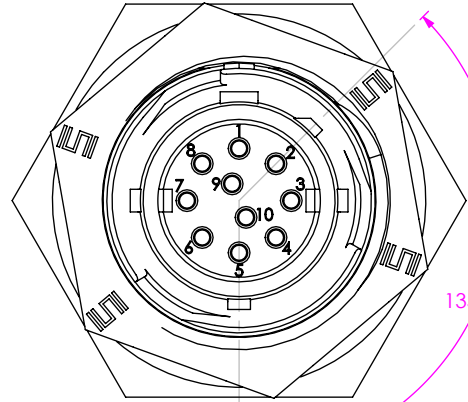

-2
(GREEN KEY RING)

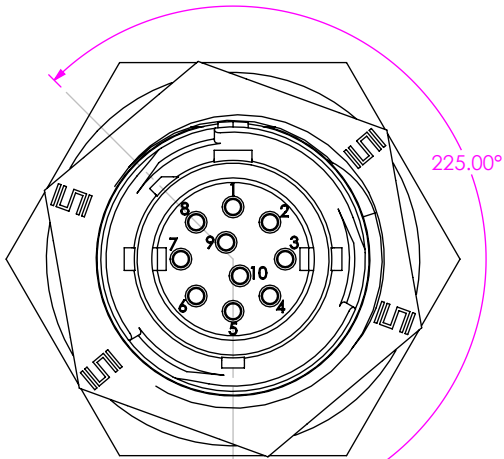

-3
(BLUE KEY RING)

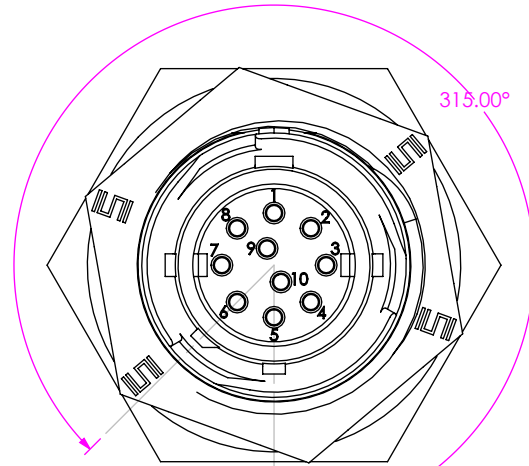

-4
(YELLOW KEY RING)

KEYING FEATURE
(SEE NOTE 4)

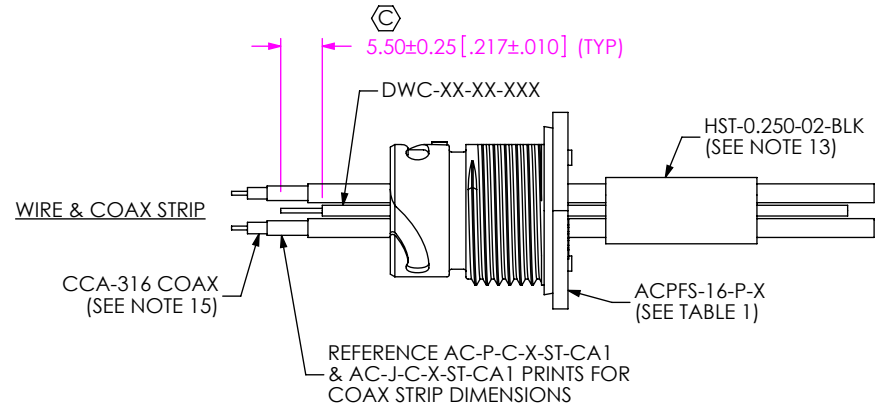

IN-PROCESS 1
FEED CABLES FROM END 2 DISCRETE CABLE ASSEMBLY THROUGH HST-0.250-02-BLK (IF APPLICABLE) & ACPFS-16-P-X. STRIP CABLES TO DIMENSIONS SHOWN & TIN INNER CONDUCTORS. FOR -BC OPTION, FEED DWC/COAX & STRIP TO DIMENSION SHOWN. (SEE NOTE 15)

KEYING FEATURE	SHELL PART #
-1	ACPFS-16-P-1
-2	ACPFS-16-P-2
-3	ACPFS-16-P-3
-4	ACPFS-16-P-4

PROPRIETARY NOTE
THIS DOCUMENT CONTAINS CONFIDENTIAL AND PROPRIETARY INFORMATION AND ALL DESIGN, MANUFACTURING, REPRODUCTION, USE, PATENT RIGHTS AND SALES RIGHTS ARE EXPRESSLY RESERVED BY SAMTEC, INC. THIS DOCUMENT SHALL NOT BE DISCLOSED, IN WHOLE OR PART, TO ANY UNAUTHORIZED PERSON OR ENTITY NOR REPRODUCED, TRANSFERRED OR INCORPORATED IN ANY OTHER PROJECT IN ANY MANNER WITHOUT THE EXPRESS WRITTEN CONSENT OF SAMTEC, INC.

DO NOT SCALE DRAWING

SHEET SCALE: 1:1



520 PARK EAST BLVD, NEW ALBANY, IN 47150
PHONE: 812-944-6733 FAX: 812-948-5047
e-Mail info@SAMTEC.com code 55322

DESCRIPTION:
M16 CABLE ASSEMBLY

DWG. NO.
ACR-16-XX-X-XX.XX-X-XX-P-X

BY: D.SCHMELZ 04/27/2010 SHEET 6 OF 8

SUB-ACTHB-16-X-XX
(SEE TABLE 3)

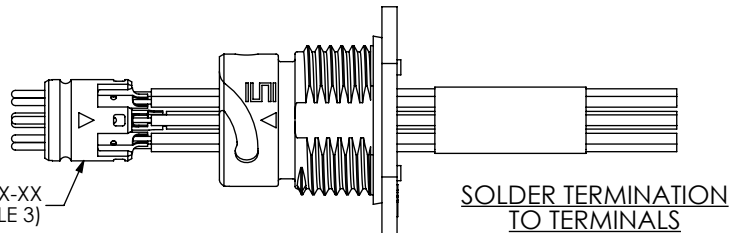

SUB-ACSHB-16-X-XX
(SEE TABLE 3)

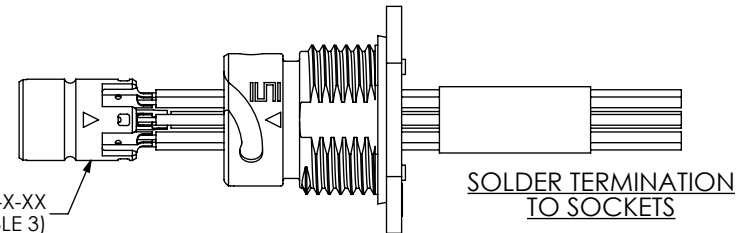

⌀ 11.50 [.453] REF

⌀ 3.20^{+0.25}_{-0.13} [.126^{+0.010}_{-.005}]

SUB-ACTHB-16-X-XX
(SEE TABLE 3)

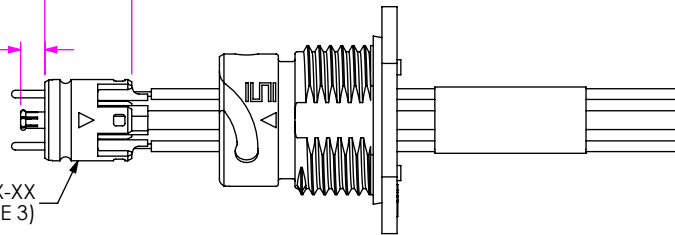

COAX PLUG INSERTION
AFTER TERMINATION, PUSH COAX PLUG INTO CORE UNTIL RETENTION BEAMS ENGAGE AND LOCK IT IN PLACE.

⌀ 15.50 [.610] REF

SUB-ACSHB-16-X-XX
(SEE TABLE 3)

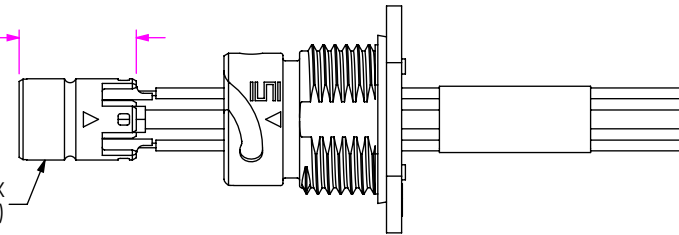

COAX JACK INSERTION
AFTER TERMINATION, PUSH COAX JACK INTO CORE UNTIL RETENTION BEAMS ENGAGE AND LOCK IT IN PLACE.

IN-PROCESS 2
TERMINATE WIRES/COAX TO TERMINALS/SOCKETS
(SEE AC-P-C-X-ST-CA1 & AC-J-C-X-ST-CA1 PRINTS FOR COAX TERMINATION)
(SEE NOTE 5)

ON LEADSTYLES -04, -05, & -07 TERMINATE & INSERT COAX PLUGS/JACKS BEFORE SOLDERING REMAINING WIRES

ON LEADSTYLES -01, -02, & -06 SOLDER INNER RING OF TERMINALS/SOCKETS FIRST AND THEN OUTER RING

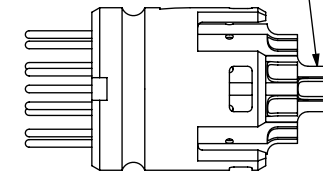
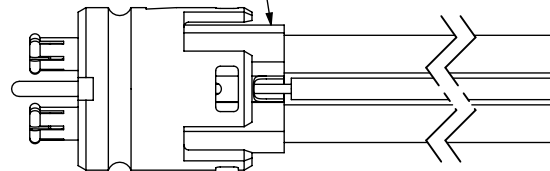

TABLE 3

LEAD STYLES	END1/END 2	SUB-ASSEMBLY/HOLDER BODY PART #		COAX PLUG/JACK PART #	
		PLATING			
		-G	-H	AC-X-C-H-ST-CA1	QTY
-01	-T	SUB-ACTHB-16-G-01	SUB-ACTHB-16-H-01	NA	
-02	-T	SUB-ACTHB-16-G-02	SUB-ACTHB-16-H-02	NA	
-03	-T	SUB-ACTHB-16-G-03	SUB-ACTHB-16-H-03	NA	
-04	-T	SUB-ACTHB-16-G-04	SUB-ACTHB-16-H-04	AC-P-C-H-ST-CA1	2
-05	-T	SUB-ACTHB-16-G-05	SUB-ACTHB-16-H-05	AC-P-C-H-ST-CA1	1
-06	-T	SUB-ACTHB-16-G-06	SUB-ACTHB-16-H-06	NA	
-07	-T	SUB-ACTHB-16-G-07	SUB-ACTHB-16-H-07	AC-P-C-H-ST-CA1	1
-01	-S	SUB-ACSHB-16-G-01	SUB-ACSHB-16-H-01	NA	
-02	-S	SUB-ACSHB-16-G-02	SUB-ACSHB-16-H-02	NA	
-03	-S	SUB-ACSHB-16-G-03	SUB-ACSHB-16-H-03	NA	
-04	-S	SUB-ACSHB-16-G-04	SUB-ACSHB-16-H-04	AC-J-C-H-ST-CA1	2
-05	-S	SUB-ACSHB-16-G-05	SUB-ACSHB-16-H-05	AC-J-C-H-ST-CA1	1
-06	-S	SUB-ACSHB-16-G-06	SUB-ACSHB-16-H-06	NA	
-07	-S	SUB-ACSHB-16-G-07	SUB-ACSHB-16-H-07	AC-J-C-H-ST-CA1	1

PROPRIETARY NOTE
THIS DOCUMENT CONTAINS CONFIDENTIAL AND PROPRIETARY INFORMATION AND ALL DESIGN, MANUFACTURING, REPRODUCTION, USE, PATENT RIGHTS AND SALES RIGHTS ARE EXPRESSLY RESERVED BY SAMTEC, INC. THIS DOCUMENT SHALL NOT BE DISCLOSED, IN WHOLE OR PART, TO ANY UNAUTHORIZED PERSON OR ENTITY NOR REPRODUCED, TRANSFERRED OR INCORPORATED IN ANY OTHER PROJECT IN ANY MANNER WITHOUT THE EXPRESS WRITTEN CONSENT OF SAMTEC, INC.

DO NOT SCALE DRAWING

SHEET SCALE: 1:1



520 PARK EAST BLVD, NEW ALBANY, IN 47150
PHONE: 812-944-6733 FAX: 812-948-5047
e-Mail info@SAMTEC.com code 55322

DESCRIPTION:
M16 CABLE ASSEMBLY
DWG. NO.
ACR-16-XX-X-XX.XX-X-XX-P-X
BY: D.SCHMELZ 04/27/2010 SHEET 7 OF 8

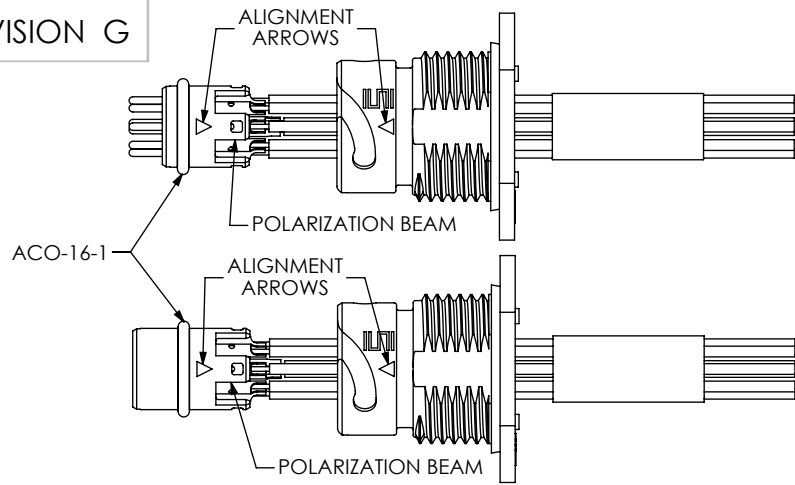

IN-PROCESS 3
 PUSH ACO-16-1 O-RING ONTO SUB-ACTHB-16-X-XX,
 OR SUB-ACSHB-16-X-XX SUB-ASSEMBLIES

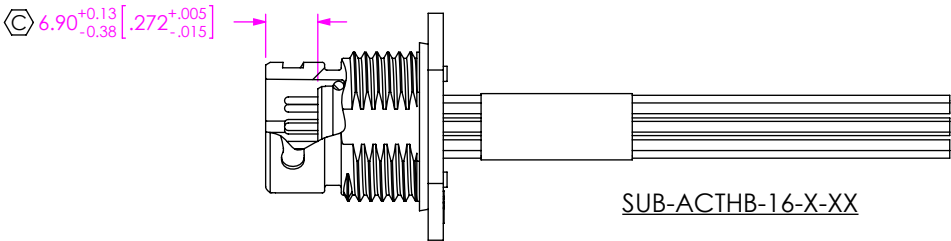

SUB-ACTHB-16-X-XX

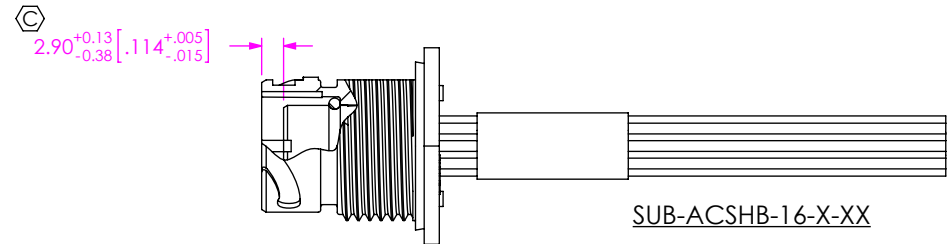

SUB-ACSHB-16-X-XX

IN-PROCESS 4
 WHILE MAKING SURE ALIGNMENT ARROWS LINE UP TO AID POLARIZATION BEAM
 ENGAGEMENT, INSERT SUB-ACXHB-16-X-XX SUB-ASSEMBLY INTO ACPFS-16-P-X
 UNTIL SNAP LOCKS ENGAGE

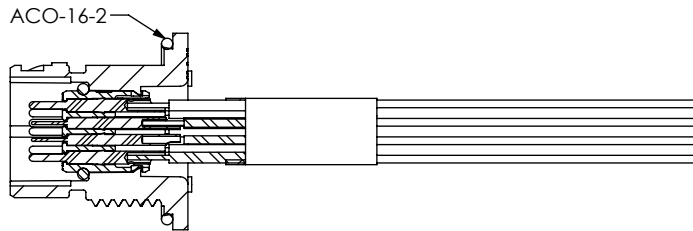

IN-PROCESS 5
 INSERT ACO-16-2 AROUND FLANGE

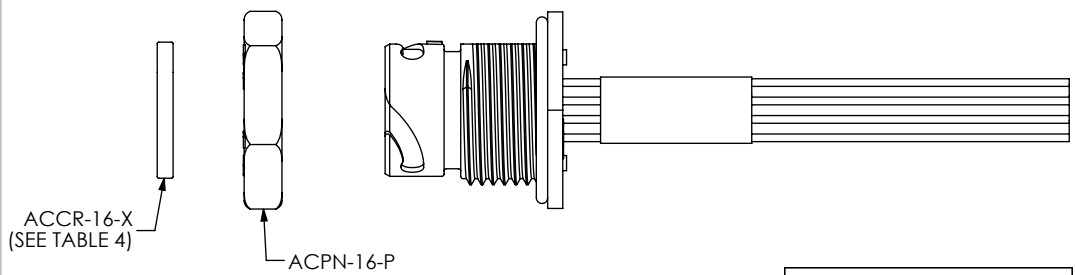

IN-PROCESS 6
 THREAD ACPN-16-P ONTO ACPFS-16-P-X
 STRETCH ACCR-16-X OVER ACPFS-16-P-X
 UNTIL IT SEATS IN GROOVE. ACTIVATE HEAT SHRINK TUBING.

TABLE 4	
KEYING FEATURE	ACCR-16-X
-1 (ORANGE)	ACCR-16-1
-2 (GREEN)	ACCR-16-2
-3 (BLUE)	ACCR-16-3
-4 (YELLOW)	ACCR-16-4

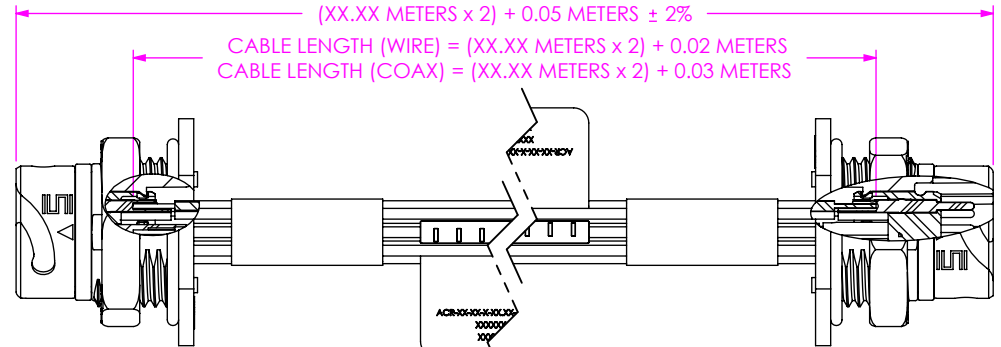

IN-PROCESS 7
 (-BC OPTION ONLY)
 BUILD DOUBLE-ENDED INITIALLY FOR E-TEST,
 APPLY LABEL-ET & HDRL-11 TO BOTH ENDS,
 AND CUT CABLE IN HALF

PROPRIETARY NOTE
 * THIS DOCUMENT CONTAINS CONFIDENTIAL AND PROPRIETARY INFORMATION AND ALL DESIGN, MANUFACTURING, REPRODUCTION, USE, PATENT RIGHTS AND SALES RIGHTS ARE EXPRESSLY RESERVED BY SAMTEC, INC. THIS DOCUMENT SHALL NOT BE DISCLOSED, IN WHOLE OR PART, TO ANY UNAUTHORIZED PERSON OR ENTITY NOR REPRODUCED, TRANSFERRED OR INCORPORATED IN ANY OTHER PROJECT IN ANY MANNER WITHOUT THE EXPRESS WRITTEN CONSENT OF SAMTEC, INC.

DO NOT SCALE DRAWING

SHEET SCALE: 1:1



520 PARK EAST BLVD, NEW ALBANY, IN 47150
 PHONE: 812-944-6733 FAX: 812-948-5047
 e-Mail: info@SAMTEC.com code 55322

DESCRIPTION:
 M16 CABLE ASSEMBLY

DWG. NO.
 ACR-16-XX-X-XX.XX-X-XX-P-X

BY: D.SCHMELZ 04/27/2010 SHEET 8 OF 8