

DO NOT SCALE FROM THIS PRINT

DESIGNED & DIMENSIONED IN MILLIMETERS [INCHES]

Pb THIS PRODUCT MANUFACTURED WITH LEAD-FREE PROCESSING

ACR-12-XX-X-XX.XX-X-XX-M-X

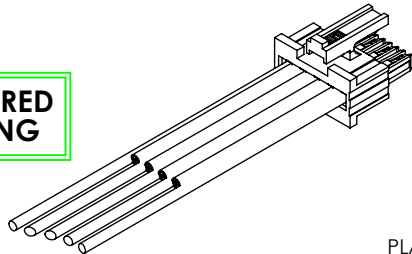

- LEAD STYLE**
- 01: 4 POS (1.0 TERM/SKT), 24 AWG
 - 02: 5 POS (1.0 TERM/SKT), 24 AWG
 - 03: 6 POS (0.5 TERM/SKT), 28 AWG
 - 04: 8 POS (0.5 TERM/SKT), 28 AWG
 - 05: 6 POS COMBO (2x1.0 TERM/SKT), 24 AWG (4x0.5 TERM/SKT), 28 AWG

- PLATING SPECIFICATION**
- G: 10µ" LIGHT GOLD IN CONTACT AREA
 - H: 30µ" HEAVY GOLD IN CONTACT AREA (SEE NOTE 10)

- KEYING FEATURE (SEE NOTE 4) (SEE SHT 5)**
- 1: ORANGE
 - 2: GREEN
 - 3: BLUE
 - 4: YELLOW

STYLE
-M: METAL

- END 2**
- BC: BLUNT CUT
 - S1: CONNECTOR (DETERMINED BY LEAD STYLE)

- END 1**
- T: TERMINAL
 - S: SOCKET

ASSEMBLED LENGTH
XX.XX (IN METERS)
(00.20 METER MIN TO 50.00 METER MAX)
(-01.00 IS CATALOG STANDARD LENGTH, FOR OTHER LENGTHS CONTACT SAMTEC)

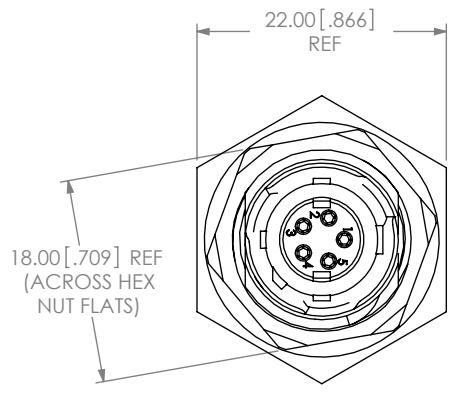
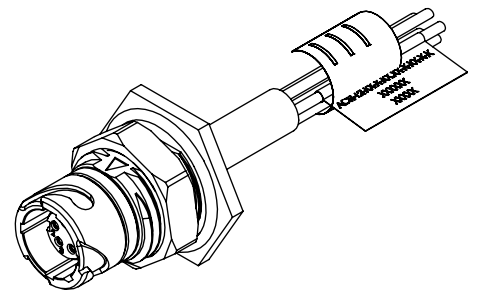

COLOR KEY RING (SEE NOTE 4)

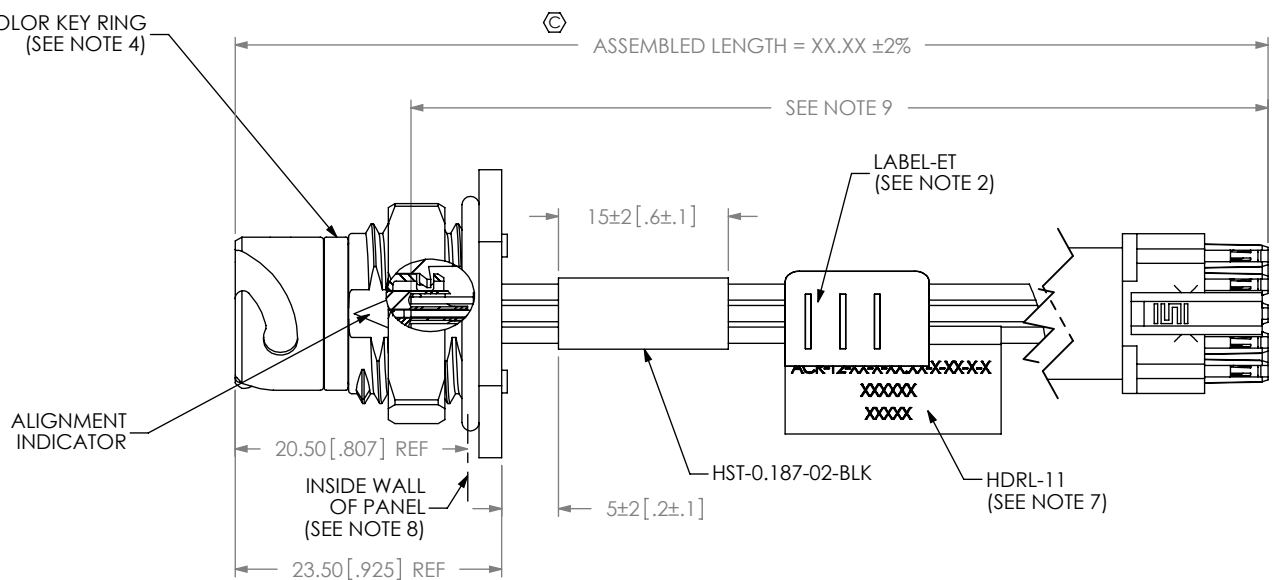

ALIGNMENT INDICATOR

FIG 1
ACR-12-02-X-XX.XX-S-S1-M-1 SHOWN

NOTES:

1. Ⓢ REPRESENTS A CRITICAL DIMENSION.
2. ASSEMBLY TO BE 100% HI-POT TESTED AT 300V.
(1) LABEL-ET TO BE APPLIED AFTER FINAL ELECTRICAL TEST.
3. ASSEMBLIES TO BE BULK PACKAGED.
4. KEYING FEATURE DETERMINES COLOR OF KEY RING AND DUSTCAP LANYARD IF APPLICABLE.
5. SIGNAL MAPPING IS 1 TO 1, 2 TO 2, 3 TO 3, ETC..
6. REFER TO DCA-ACR-12-M-X PRINT FOR DUST CAP.
7. PLACE HDRL-11 (LABEL) ON CABLE WHERE SHOWN. LABEL TO CONTAIN:
LINE 1 - PART NUMBER "ACR-12-XX-X-XX.XX-X-XX-M-X"
LINE 2 - SHOP ORDER NUMBER "XXXXXX"
LINE 3 - DATE CODE "XXXXX"
8. PANEL THICKNESS RANGE: 0.80[0.031] - 5.20[0.205]
9. FOR END 2 CABLE LENGTH REFERENCE END 2 OPTIONS ON SHEET 3.
10. END 2 CONNECTOR PLATING TO BE 10µ GOLD.
11. PARTS TO BE BUILT AND INSPECTED TO IPC-A-620 CLASS 2.
12. WHEN MOUNTING PRODUCT TO PANEL TORQUE ACPN-12-M TO 15IN-LBS.

UNLESS OTHERWISE SPECIFIED, DIMENSIONS ARE IN MILLIMETERS.
TOLERANCES ARE:
DECIMALS ANGLES
X.X: ±0.3 [.01] 2°
X.XX: ±0.13 [.005]
X.XXX: ±0.051 [.0020]

PROPRIETARY NOTE
THIS DOCUMENT CONTAINS INFORMATION CONFIDENTIAL AND PROPRIETARY TO SAMTEC, INC. AND SHALL NOT BE REPRODUCED OR TRANSFERRED TO OTHER DOCUMENTS OR DISCLOSED TO OTHERS OR USED FOR ANY PURPOSE OTHER THAN THAT WHICH IT WAS OBTAINED WITHOUT THE EXPRESSED WRITTEN CONSENT OF SAMTEC, INC.



520 PARK EAST BLVD, NEW ALBANY, IN 47150
PHONE: 812-944-6733 FAX: 812-948-5047
e-Mail info@SAMTEC.com code 55322

MATERIAL: DO NOT SCALE DRAWING SHEET SCALE: 3:2
SHELL: ZINC ALLOY
INSULATOR: PBT, COLOR: BLACK
TERMINALS: BRASS
CONTACTS: BRASS/BeCu

DESCRIPTION: M12 CABLE ASSEMBLY
DWG. NO. ACR-12-XX-X-XX.XX-X-XX-M-X
BY: D.SCHMELZ 09/17/2010 SHEET 1 OF 6

-T END OPTIONS

-01: 4 POS
Ø 1.0 TERMINALS

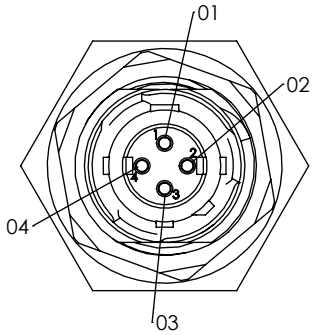

-02: 5 POS
Ø 1.0 TERMINALS

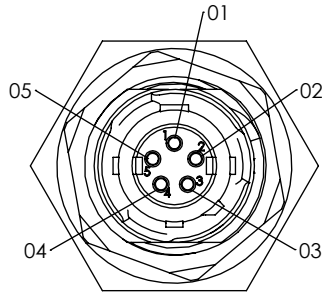

-03: 6 POS
Ø 0.5 TERMINALS

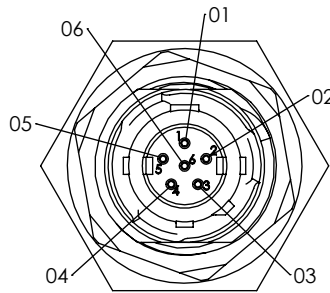

-04: 8 POS
Ø 0.5 TERMINALS

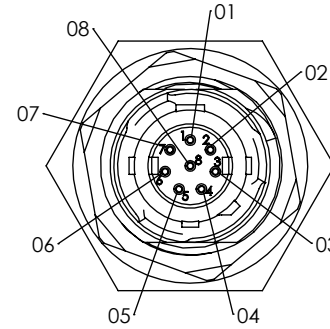

-05: 6 POS COMBO
2x Ø 1.0 TERMINALS
4x Ø 0.5 TERMINALS

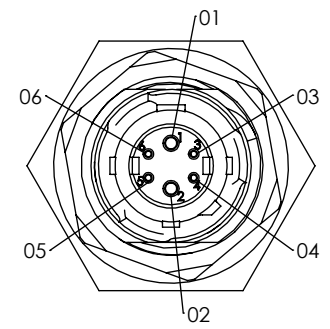

-S END OPTIONS

-01: 4 POS
Ø 1.0 SOCKETS

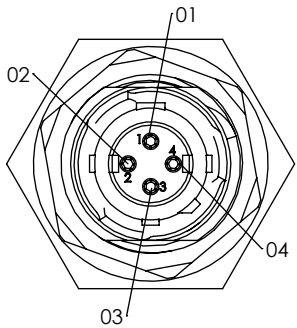

-02: 5 POS
Ø 1.0 SOCKETS

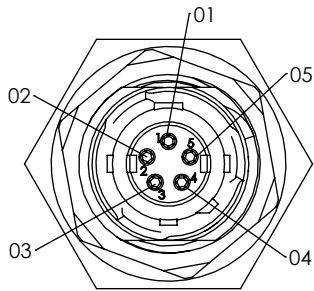

-03: 6 POS
Ø 0.5 SOCKETS

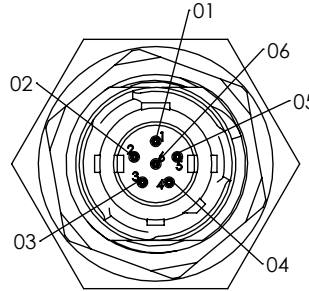

-04: 8 POS
Ø 0.5 SOCKETS

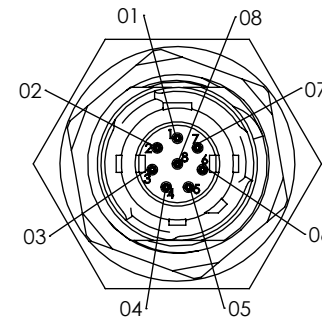

-05: 6 POS COMBO
2x Ø 1.0 SOCKETS
4x Ø 0.5 SOCKETS

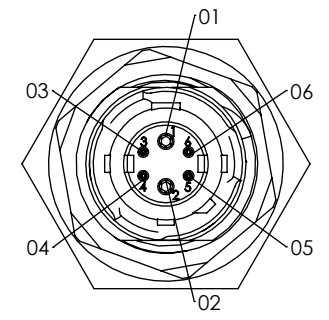

PROPRIETARY NOTE

THIS DOCUMENT CONTAINS INFORMATION CONFIDENTIAL AND PROPRIETARY TO SAMTEC, INC. AND SHALL NOT BE REPRODUCED OR TRANSFERRED TO OTHER DOCUMENTS OR DISCLOSED TO OTHERS OR USED FOR ANY PURPOSE OTHER THAN THAT WHICH IT WAS OBTAINED WITHOUT THE EXPRESSED WRITTEN CONSENT OF SAMTEC, INC.

DO NOT SCALE DRAWING

SHEET SCALE: 1.5:1

samtec

520 PARK EAST BLVD, NEW ALBANY, IN 47150
PHONE: 812-944-6733 FAX: 812-948-5047
e-Mail info@SAMTEC.com code 55322

DESCRIPTION:
M12 CABLE ASSEMBLY

DWG. NO.
ACR-12-XX-X-XX.XX-X-XX-M-X

BY: D.SCHMELZ 09/17/2010 SHEET 2 OF 6

-01: 4 POS
MMSS-04-24-L-XX.XX-S-K

END 2 OPTIONS

-02: 5 POS
MMSS-05-24-L-XX.XX-S-K

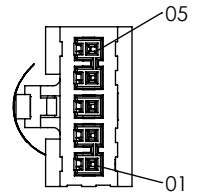
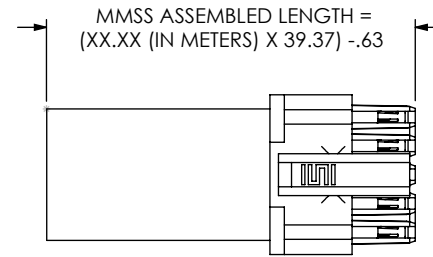
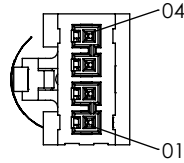
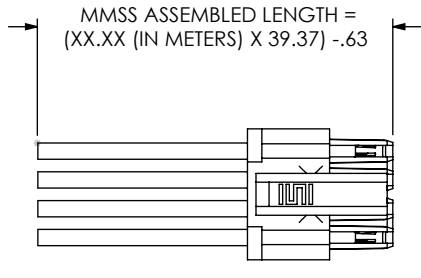

-03: 6 POS
SFSS-06-28-G-XX.XX-SR

SFSS ASSEMBLED LENGTH =
(XX.XX (IN METERS) X 39.37) -.63

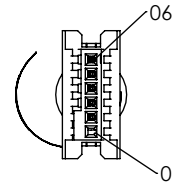

-05: 6 POS COMBO
SUB-MMSS-06-L-XX.XX-S-K

SUB-MMSS ASSEMBLED LENGTH =
(XX.XX (IN METERS) X 39.37) -.63

28 AWG
BLACK WIRES

24 AWG
RED WIRES
(POSITIONS 1 & 2)

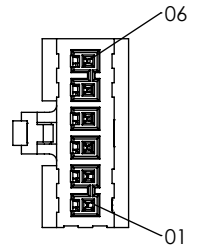
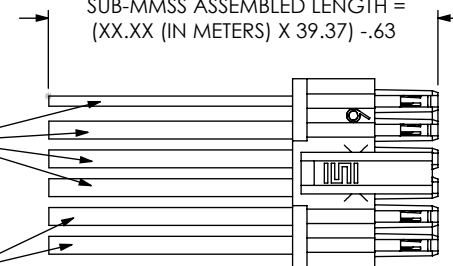

-04: 8 POS
SFSS-08-28-G-XX.XX-SR

SFSS ASSEMBLED LENGTH =
(XX.XX (IN METERS) X 39.37) -.63

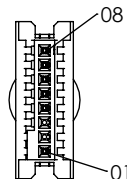
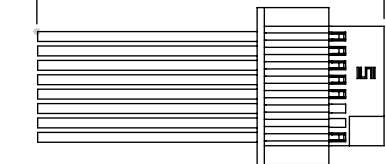

PROPRIETARY NOTE

THIS DOCUMENT CONTAINS INFORMATION CONFIDENTIAL AND PROPRIETARY TO SAMTEC, INC. AND SHALL NOT BE REPRODUCED OR TRANSFERRED TO OTHER DOCUMENTS OR DISCLOSED TO OTHERS OR USED FOR ANY PURPOSE OTHER THAN THAT WHICH IT WAS OBTAINED WITHOUT THE EXPRESSED WRITTEN CONSENT OF SAMTEC, INC.

DO NOT SCALE DRAWING

SHEET SCALE: 1.5:1

samtec

520 PARK EAST BLVD, NEW ALBANY, IN 47150
PHONE: 812-944-6733 FAX: 812-948-5047
e-Mail info@SAMTEC.com code 55322

DESCRIPTION:

M12 CABLE ASSEMBLY

DWG. NO.

ACR-12-XX-X-XX.XX-X-XX-M-X

BY: D.SCHMELZ 09/17/2010 SHEET 3 OF 6

-BC END 2 OPTION
(BUILD DOUBLE-ENDED INITIALLY FOR E-TEST)
(SEE IN-PROCESS 6)

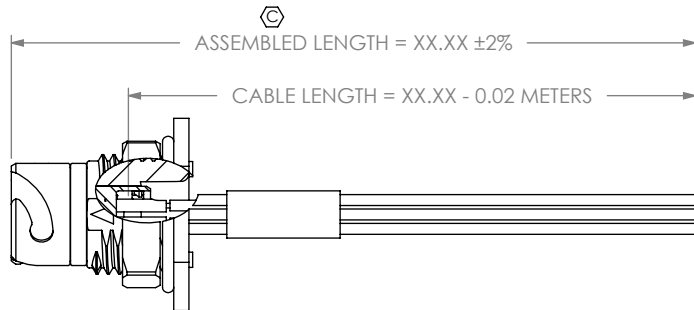

RECOMMENDED PANEL OPENING
(SEE NOTE 8)

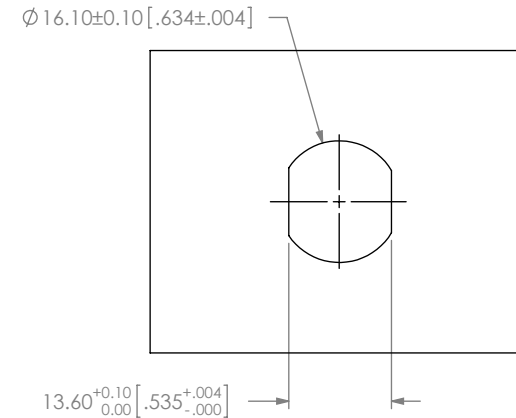

TABLE 2

-BC LEAD STYLES ONLY

POSITION	-01		-02		-03		-04		-05			
	COLOR	DWC-XX-XX-XXX	COLOR	DWC-XX-XX-XXX	COLOR	DWC-XX-XX-XXX	COLOR	DWC-XX-XX-XXX	COLOR	DWC-XX-XX-XXX		
01	BROWN	DWC-24-01-300	BROWN	DWC-24-01-300	BROWN	DWC-28H-01-300	BROWN	DWC-28H-01-300	BROWN	DWC-24-01-300		
02	RED	DWC-24-02-300	RED	DWC-24-02-300	RED	DWC-28H-02-300	RED	DWC-28H-02-300	RED	DWC-24-02-300		
03	ORANGE	DWC-24-03-300	ORANGE	DWC-24-03-300	ORANGE	DWC-28H-03-300	ORANGE	DWC-28H-03-300	ORANGE	DWC-28H-03-300		
04	YELLOW	DWC-24-04-300	YELLOW	DWC-24-04-300	YELLOW	DWC-28H-04-300	YELLOW	DWC-28H-04-300	YELLOW	DWC-28H-04-300		
05	NA		GREEN	DWC-24-05-300	GREEN	DWC-28H-05-300	GREEN	DWC-28H-05-300	GREEN	DWC-28H-05-300		
06			NA		DARK BLUE	DWC-28H-06-300	DARK BLUE	DWC-28H-06-300	DARK BLUE	DWC-28H-06-300		
07					NA		NA		VIOLET	DWC-28H-07-300	NA	
08							NA		GRAY	DWC-28H-08-300	NA	

PROPRIETARY NOTE

THIS DOCUMENT CONTAINS INFORMATION CONFIDENTIAL AND PROPRIETARY TO SAMTEC, INC. AND SHALL NOT BE REPRODUCED OR TRANSFERRED TO OTHER DOCUMENTS OR DISCLOSED TO OTHERS OR USED FOR ANY PURPOSE OTHER THAN THAT WHICH IT WAS OBTAINED WITHOUT THE EXPRESSED WRITTEN CONSENT OF SAMTEC, INC.

DO NOT SCALE DRAWING

SHEET SCALE: 1:5:1



520 PARK EAST BLVD, NEW ALBANY, IN 47150
PHONE: 812-944-6733 FAX: 812-948-5047
e-Mail info@SAMTEC.com code 55322

DESCRIPTION:

M12 CABLE ASSEMBLY

DWG. NO.

ACR-12-XX-X-XX.XX-X-XX-M-X

BY: D.SCHMELZ 09/17/2010 SHEET 4 OF 6

KEYING FEATURE
(SEE NOTE 4)

-1
ORANGE KEY RING

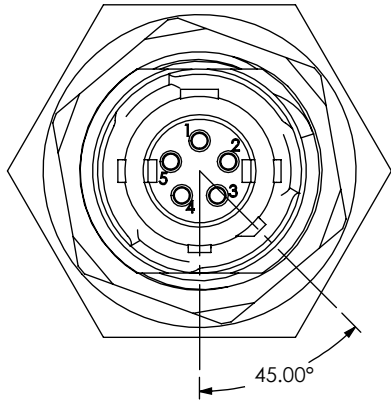

-2
GREEN KEY RING

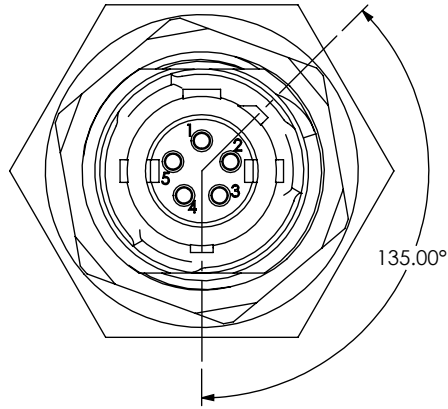

-3
BLUE KEY RING

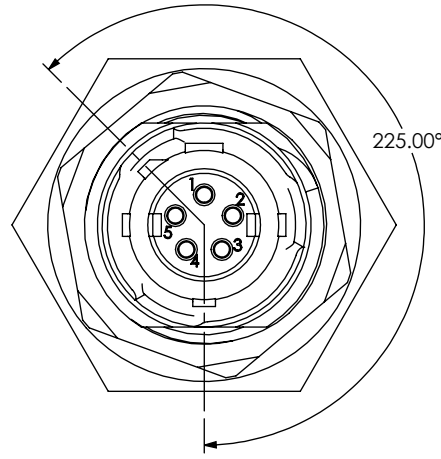

-4
YELLOW KEY RING

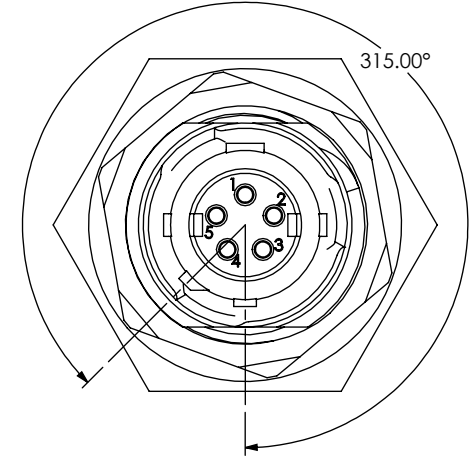

IN-PROCESS 1
FEED CABLES THROUGH HST-0.187-02-BLK & ACPFS-12-M-X
& STRIP CABLES TO DIMENSIONS SHOWN & TIN INNER CONDUCTORS

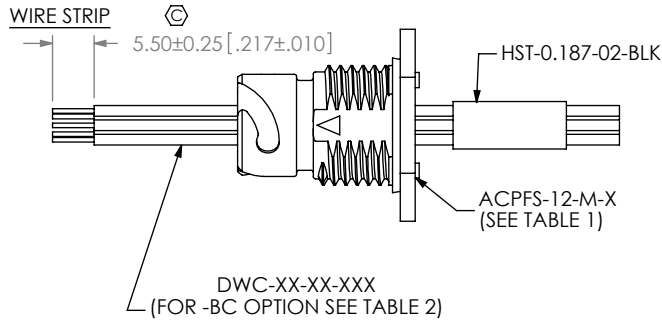

KEYING FEATURE	SHELL PART #
-1	ACPFS-12-M-1
-2	ACPFS-12-M-2
-3	ACPFS-12-M-3
-4	ACPFS-12-M-4

IN-PROCESS 2
TERMINATE WIRES TO TERMINALS/SOCKETS

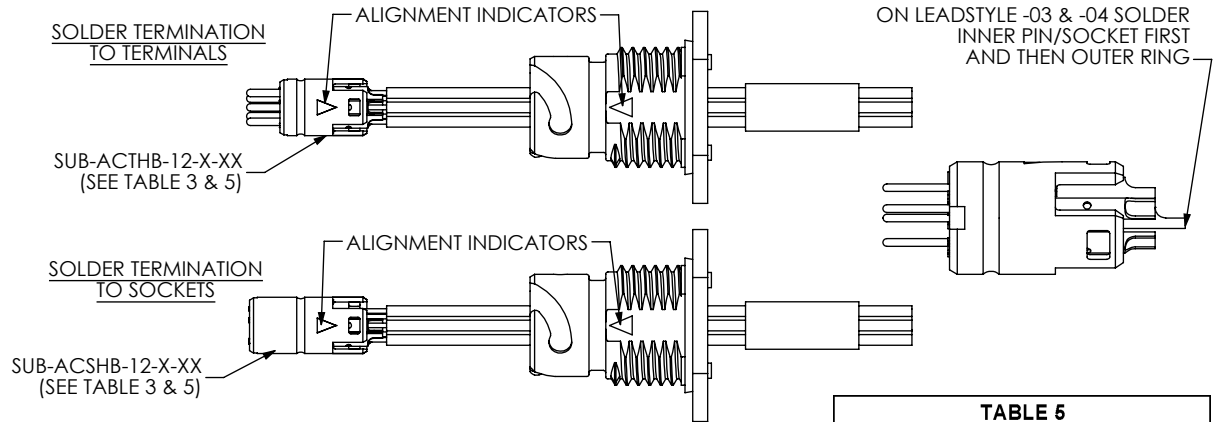

LEAD STYLE	END1/END 2	SUB-ACXHB-12-X-XX
-01	-T	SUB-ACTHB-12-X-01
-02	-T	SUB-ACTHB-12-X-02
-03	-T	SUB-ACTHB-12-X-03
-04	-T	SUB-ACTHB-12-X-04
-05	-T	SUB-ACTHB-12-X-05
-01	-S	SUB-ACSHB-12-X-01
-02	-S	SUB-ACSHB-12-X-02
-03	-S	SUB-ACSHB-12-X-03
-04	-S	SUB-ACSHB-12-X-04
-05	-S	SUB-ACSHB-12-X-05

PLATING	SUB-ACXHB-12-X-XX
-G	SUB-ACXHB-12-G-XX
-H	SUB-ACXHB-12-H-XX

F:\DWG\MISC\MKTG\ACR-12-XX-X-XX.XX-X-XX-M-X-MKT.SLDDRW

PROPRIETARY NOTE
THIS DOCUMENT CONTAINS INFORMATION CONFIDENTIAL AND PROPRIETARY TO SAMTEC, INC. AND SHALL NOT BE REPRODUCED OR TRANSFERRED TO OTHER DOCUMENTS OR DISCLOSED TO OTHERS OR USED FOR ANY PURPOSE OTHER THAN THAT WHICH IT WAS OBTAINED WITHOUT THE EXPRESSED WRITTEN CONSENT OF SAMTEC, INC.

DO NOT SCALE DRAWING

SHEET SCALE: 1:1



520 PARK EAST BLVD, NEW ALBANY, IN 47150
PHONE: 812-944-6733 FAX: 812-948-5047
e-Mail: info@SAMTEC.com code 55322

DESCRIPTION:
M12 CABLE ASSEMBLY

DWG. NO.
ACR-12-XX-X-XX.XX-X-XX-M-X

BY: D.SCHMELZ 09/17/2010 SHEET 5 OF 6

IN-PROCESS 3

PUSH ACO-12-1 O-RING ONTO SUB-ACXHB-12-X-XX.

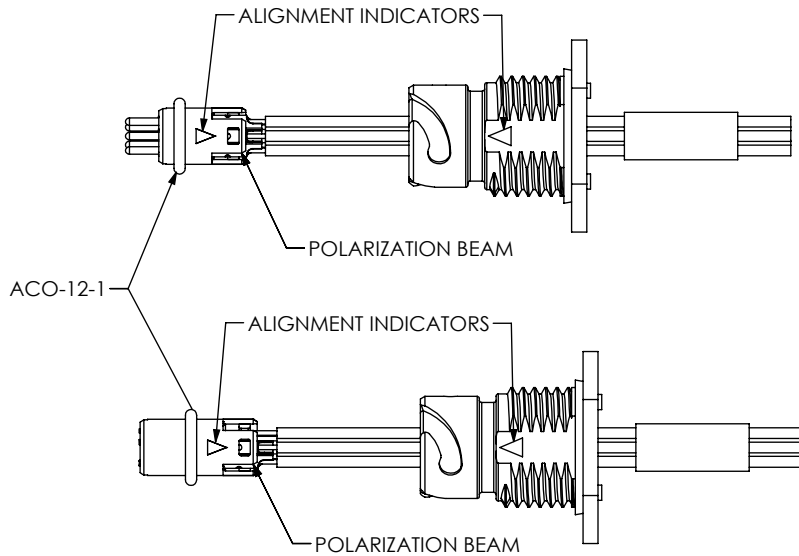

IN-PROCESS 5

PRESS ACO-12-2 O-RING AROUND FLANGE OF ACPFS-12-M-X
 THREAD ACPN-12-M ONTO ACPFS-12-M-X
 STRETCH ACCR-12-X OVER ACPFS-12-M-X UNTIL IT SEATS IN GROOVE
 ACTIVATE HST-0.187-02-BLK USING HEAT GUN

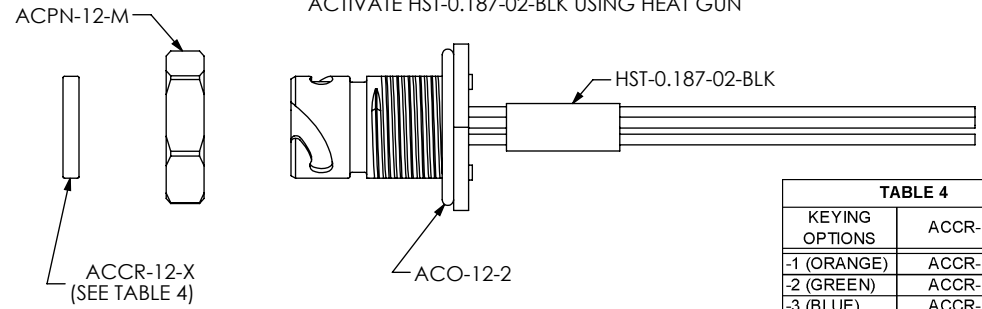
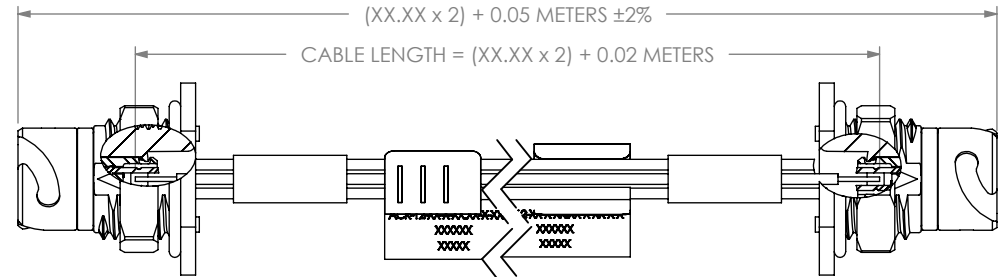

TABLE 4	
KEYING OPTIONS	ACCR-12-X
-1 (ORANGE)	ACCR-12-1
-2 (GREEN)	ACCR-12-2
-3 (BLUE)	ACCR-12-3
-4 (YELLOW)	ACCR-12-4

IN-PROCESS 6

(-BC OPTION ONLY)
 BUILD DOUBLE-ENDED INITIALLY FOR E-TEST,
 APPLY LABEL-ET & HDRL-11 TO BOTH ENDS,
 AND CUT CABLE IN HALF



IN-PROCESS 4

WHILE MAKING SURE THE ALIGNMENT ARROWS LINE UP TO AID POLARIZATION BEAM ENGAGEMENT, INSERT SUB-ACXHB-12-X-XX UNTIL SNAP LOCKS ENGAGE.

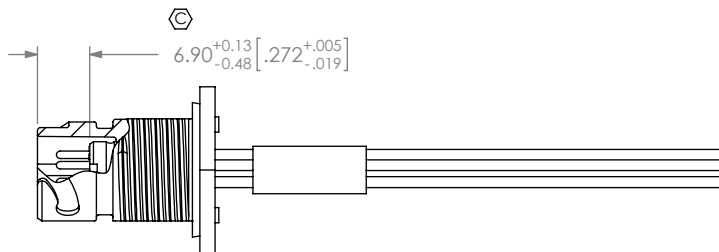

SUB-ACTHB-12-X-XX

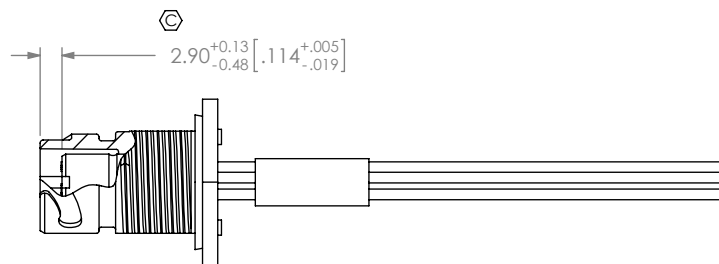

SUB-ACSHB-12-X-XX

PROPRIETARY NOTE

THIS DOCUMENT CONTAINS INFORMATION CONFIDENTIAL AND PROPRIETARY TO SAMTEC, INC. AND SHALL NOT BE REPRODUCED OR TRANSFERRED TO OTHER DOCUMENTS OR DISCLOSED TO OTHERS OR USED FOR ANY PURPOSE OTHER THAN THAT WHICH IT WAS OBTAINED WITHOUT THE EXPRESSED WRITTEN CONSENT OF SAMTEC, INC.

DO NOT SCALE DRAWING

SHEET SCALE: 1:1



520 PARK EAST BLVD, NEW ALBANY, IN 47150
 PHONE: 812-944-6733 FAX: 812-948-5047
 e-Mail info@SAMTEC.com code 55322

DESCRIPTION: M12 CABLE ASSEMBLY

DWG. NO. ACR-12-XX-X-XX.XX-X-XX-M-X

BY: D.SCHMELZ 09/17/2010 SHEET 6 OF 6