

Features

- High current operation for greater luminous output
- Low power consumption and thermal resistance
- Can be used with automatic insertion equipment
- RoHS Compliant



Benefits:

- Rugged design allows for easy maintenance
- Robust package for optimum reliability

Typical Applications:

- Automotive side markers
- Gaming and entertainment lighting
- Signs and road hazard indicators



ATTENTION
OBSERVE PRECAUTIONS
FOR HANDLING
ELECTROSTATIC
DISCHARGE
SENSITIVE
DEVICES

Package Schematics

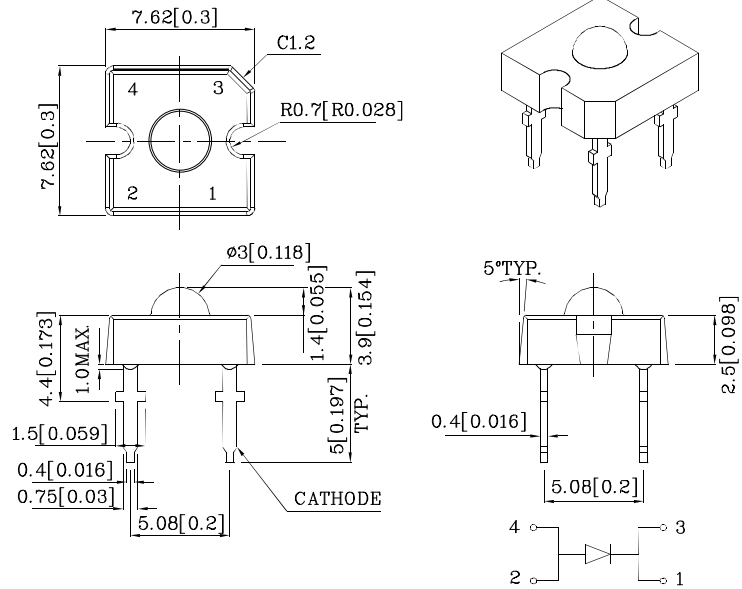

Notes:

1. All dimensions are in millimeters (inches).
2. Tolerance is $\pm 0.25(0.01)$ unless otherwise noted.
3. Specifications are subject to change without notice.

Absolute Maximum Ratings ($T_A=25^\circ\text{C}$)		Yellow (AlGaInP)	Unit
Reverse Voltage	V_R	5	V
DC Forward Current	I_F	70	mA
Power Dissipation	P_D	210	mW
Operating Temperature	T_A	-40 ~ +85	°C
Storage Temperature	T_{stg}	-55 ~ +85	
Lead Solder Temperature [1.5mm Below Seating Plane.][1]		260°C For 5 Seconds	

Operating Characteristics ($T_A=25^\circ\text{C}$)		Yellow (AlGaInP)	Unit
Forward Voltage (Min.) ($I_F=70\text{mA}$)	V_F	2.2	V
Forward Voltage (Typ.) ($I_F=70\text{mA}$)	V_F	2.4	V
Forward Voltage (Max.) ($I_F=70\text{mA}$)	V_F	3.0	V
Reverse Current (Max.) ($V_R=5\text{V}$)	I_R	10	μA
Wavelength of Peak Emission CIE127-2007*(Typ.) ($I_F=70\text{mA}$)	λ_P	590*	nm
Wavelength of Dominant Emission CIE127-2007*(Typ.) ($I_F=70\text{mA}$)	λ_D	590*	nm
Spectral Line Full Width At Half Maximum (Typ.) ($I_F=70\text{mA}$)	$\Delta\lambda$	20	nm
Capacitance (Typ.) ($V_F=0\text{V}$, $f=1\text{MHz}$)	C	45	pF
Thermal Resistance (Typ.)	$R_{\theta j-pin}$	125	°C/W

1.No Reflow soldering .

2.A Relative Humidity between 40% and 60% is recommended in ESD-protected work areas to reduce static build up during assembly process (Reference JEDEC/JESD625-A and JEDEC/J-STD-033)

Part Number	Emitting Color	Emitting Material	Lens-color	Luminous Intensity CIE127-2007* ($I_F=70\text{mA}$) cd			Luminous Flux CIE127-2007* ($I_F=70\text{mA}$) lm	Wavelength CIE127-2007* λ_P nm	Viewing Angle 2 θ 1/2
				min.	typ.	typ.			
XSM2CYK983W	Yellow	AlGaInP	Water Clear	3.1*	4.99*	5.3*	590*	70°	

1.Luminous intensity is measured with an integrating sphere after the device has stabilized.

2.0 1/2 is the angle from optical centerline where the luminous intensity is 1/2 of the optical peak value.

3.LEDs are binned according to their Luminous intensity.

* Luminous intensity / luminous flux value and wavelength are in accordance with CIE127-2007 standards.

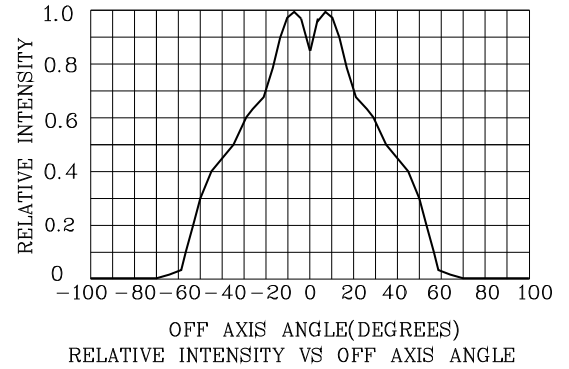
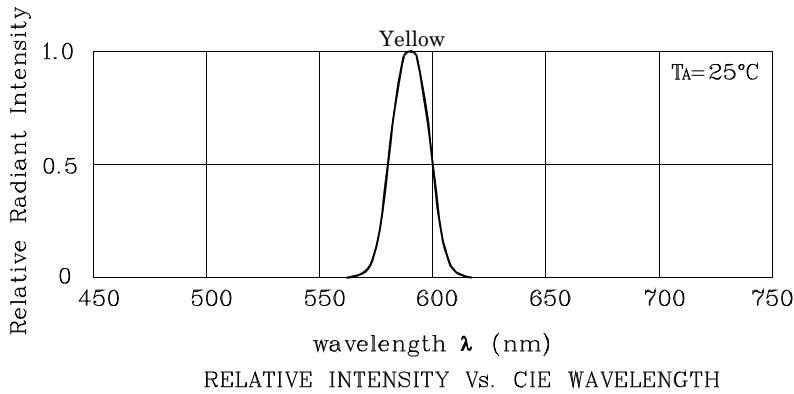

❖ Yellow

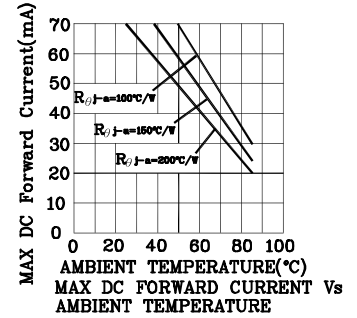
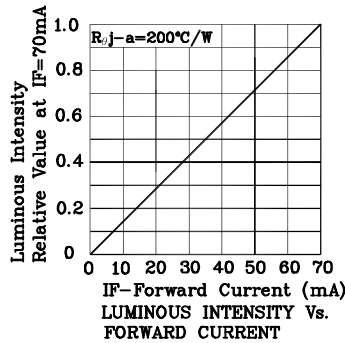
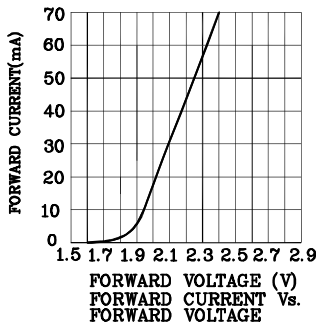

Wave Soldering Profile For Thru-Hole Products (Pb-Free Components)

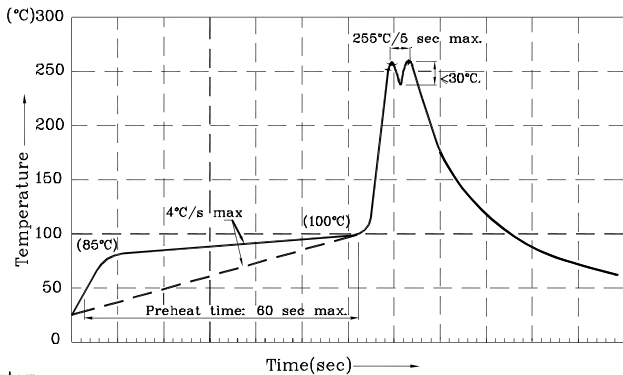

- Notes:
- 1.Recommend pre-heat temperature of 105°C or less (as measured with a thermocouple attached to the LED pins) prior to immersion in the solder wave with a maximum solder bath temperature of 260°C
 - 2.Peak wave soldering temperature between 245°C ~ 255°C for 3 sec (5 sec max).
 - 3.Do not apply stress to the epoxy resin while the temperature is above 85°C.
 - 4.Fixtures should not incur stress on the component when mounting and during soldering process.
 - 5.SAC 305 solder alloy is recommended.
 - 6.No more than one wave soldering pass.

Remarks:

If special sorting is required (e.g. binning based on forward voltage, luminous intensity / luminous flux, or wavelength), the typical accuracy of the sorting process is as follows:

1. Wavelength: +/-1nm
2. Luminous Intensity / Luminous Flux: +/-15%
3. Forward Voltage: +/-0.1V



Note: Accuracy may depend on the sorting parameters.

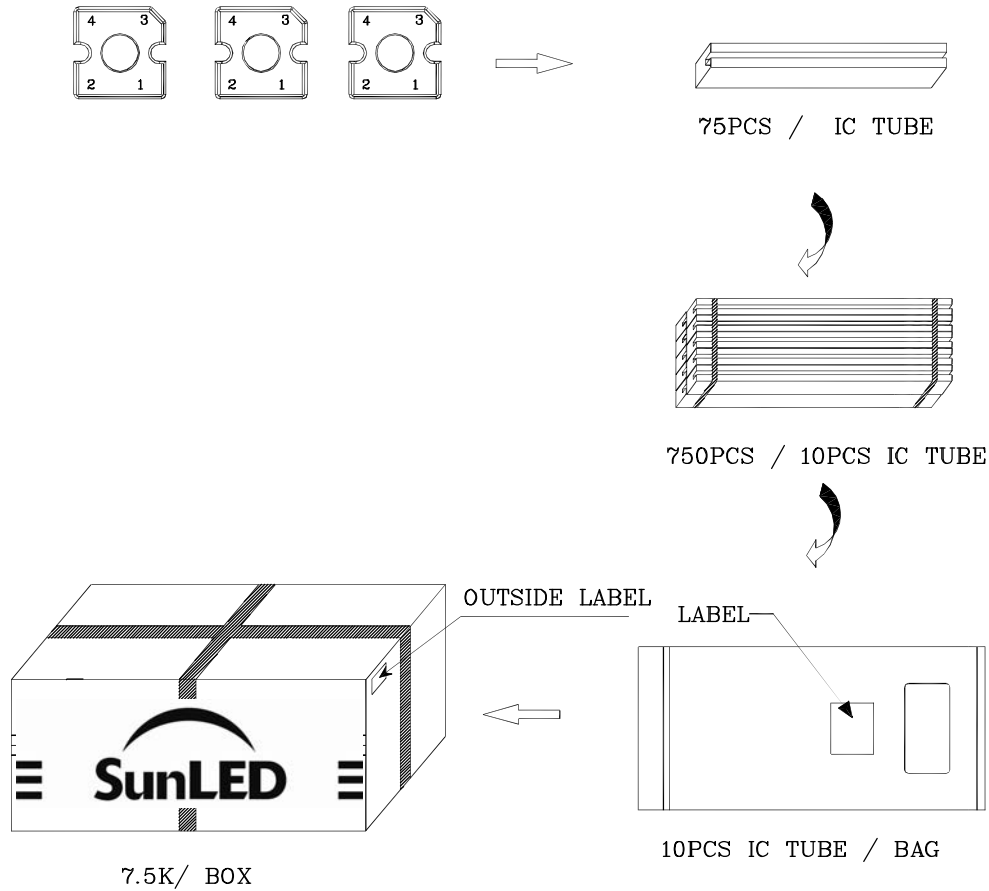

PACKING & LABEL SPECIFICATIONS



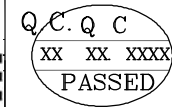

	
P/NO : XSxxx983x	
QTY : 750 pcs	CODE: XXX
S/N : XX	
LOT NO:	
 XXXXXXXXXXXXXXXXXXXXXXXXXXXX	
RoHS Compliant	

TERMS OF USE

1. Data presented in this document reflect statistical figures and should be treated as technical reference only.
2. Contents within this document are subject to improvement and enhancement changes without notice.
3. The product(s) in this document are designed to be operated within the electrical and environmental specifications indicated on the datasheet.
User accepts full risk and responsibility when operating the product(s) beyond their intended specifications.
4. The product(s) described in this document are intended for electronic applications in which a person's life is not reliant upon the LED. Please consult with a SunLED representative for special applications where the LED may have a direct impact on a person's life.
5. The contents within this document may not be altered without prior consent by SunLED.
6. Additional technical notes are available at <http://www.SunLEDusa.com/TechnicalNotes.asp>