

PXAD214218FV

Thermally-Enhanced High Power RF LDMOS FET 430 W, 28 V, 2110 – 2170 MHz

Description

The PXAD214218FV is a 430-watt (P_{3dB}) LDMOS FET with an asymmetrical design intended for use in multi-standard cellular power amplifier applications in the 2110 to 2170 MHz frequency band. Features include dual-path design, input and output matching, high gain and thermally-enhanced package with earless flanges. Manufactured with Wolfsped's advanced LDMOS process, this device provides excellent thermal performance and superior reliability.

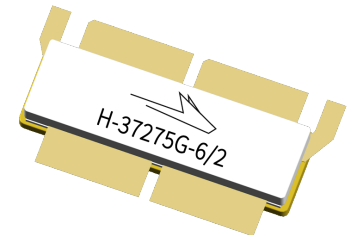

PXAD214218FV
Package H-37275G-6/2

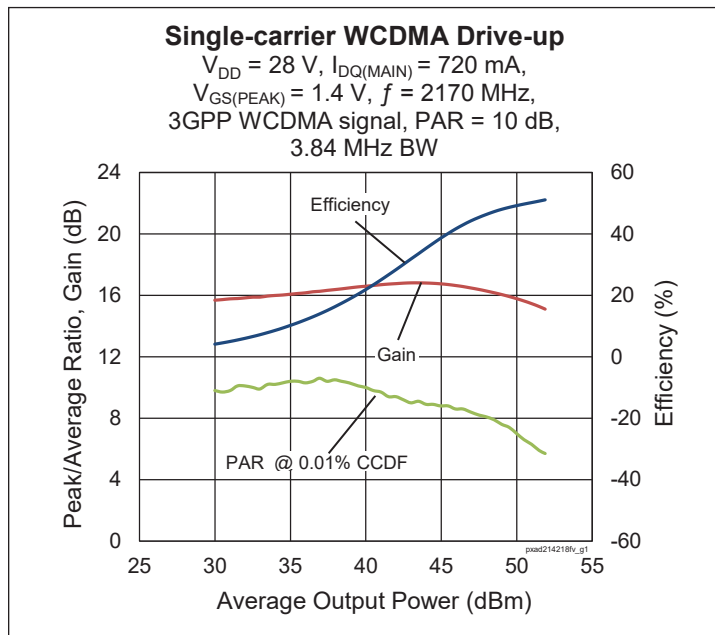

Features

- Broadband internal input and output matching
- Asymmetrical Doherty design
 - Main : $P_{1dB} = 130\text{ W Typ}$
 - Peak : $P_{1dB} = 290\text{ W Typ}$
- Typical Pulsed CW performance, 2140 MHz, 28 V, Doherty configuration
 - Output power at $P_{3dB} = 436\text{ W}$
 - Efficiency = 55%
 - Gain = 13.5 dB
- Capable of handling 10:1 VSWR @28 V, 110 W (WCDMA) output power
- Integrated ESD protection
- Human Body Model class 2 (per ANSI/ESDA/ JEDEC JS-001)
- Low thermal resistance
- Pb-free and RoHS compliant

RF Characteristics

Two-carrier WCDMA Specifications (tested in Wolfsped Doherty production test fixture)

$V_{DD} = 28\text{ V}$, $I_{DQ} = 720\text{ mA}$, $V_{GS(PEAK)} = 1.5\text{ V}$, $P_{OUT} = 56\text{ W avg}$, $f = 2170\text{ MHz}$, 3GPP signal, channel bandwidth = 3.84 MHz, peak/average = 10 dB @ 0.01% CCDF

Characteristic	Symbol	Min	Typ	Max	Unit
Linear Gain	G_{ps}	15	16	—	dB
Drain Efficiency	η_D	45	48.7	—	%
Adjacent Channel Power Ratio	ACPR	—	-24.5	-22	dBc
Output PAR@0.01% CCDF	OPAR	6.1	7.4	—	dBc

All published data at $T_{CASE} = 25^\circ\text{C}$ unless otherwise indicated

ESD: Electrostatic discharge sensitive device—observe handling precautions!

DC Characteristics (each side)

Characteristic	Conditions	Symbol	Min	Typ	Max	Unit
Drain-Source Breakdown Voltage	$V_{GS} = 0\text{ V}, I_{DS} = 10\text{ mA}$	$V_{(BR)DSS}$	65	—	—	V
Drain Leakage Current	$V_{DS} = 28\text{ V}, V_{GS} = 0\text{ V}$	I_{DSS}	—	—	1	μA
	$V_{DS} = 63\text{ V}, V_{GS} = 0\text{ V}$	I_{DSS}	—	—	10	μA
Gate Leakage Current	$V_{GS} = 10\text{ V}, V_{DS} = 0\text{ V}$	I_{GSS}	—	—	1	μA
On-State Resistance (Main)	$V_{GS} = 10\text{ V}, V_{DS} = 0.1\text{ V}$	$R_{DS(on)}$	—	0.09	—	Ω
	(Peak) $V_{GS} = 10\text{ V}, V_{DS} = 0.1\text{ V}$	$R_{DS(on)}$	—	0.05	—	Ω
Operating Gate Voltage (Main)	$V_{DS} = 28\text{ V}, I_{DQ} = 720\text{ mA}$	V_{GS}	2.3	2.7	2.9	V
	(Peak) $V_{DS} = 28\text{ V}, I_{DQ} = 0\text{ mA}$	V_{GS}	—	1.4	—	V

Maximum Ratings

Parameter	Symbol	Value	Unit
Drain-Source Voltage	V_{DSS}	65	V
Gate-Source Voltage	V_{GS}	-6 to +10	V
Junction Temperature	T_J	225	$^{\circ}\text{C}$
Storage Temperature Range	T_{STG}	-65 to +150	$^{\circ}\text{C}$

Thermal Characteristics

Parameter	Symbol	Value	Unit
Thermal Resistance (Main, $T_{CASE} = 70^{\circ}\text{C}$, 60 W CW)	$R_{\theta JC}$	0.44	$^{\circ}\text{C}/\text{W}$
(Peak, $T_{CASE} = 70^{\circ}\text{C}$, 280 W CW)	$R_{\theta JC}$	0.246	$^{\circ}\text{C}/\text{W}$

Ordering Information

Type and Version	Order Code	Package Description	Shipping
PXAD214218FV V1 R0	PXAD214218FV-V1-R0	H-37275G-6/2,	Tape & Reel, 50 pcs
PXAD214218FV V1 R2	PXAD214218FV-V1-R2	H-37275G-6/2,	Tape & Reel, 250 pcs



Typical RF Performance (data taken in production test fixture)

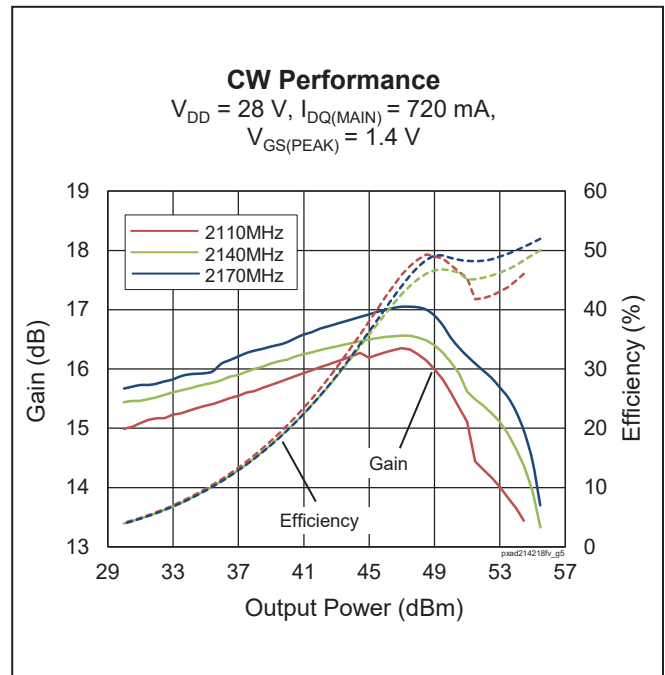
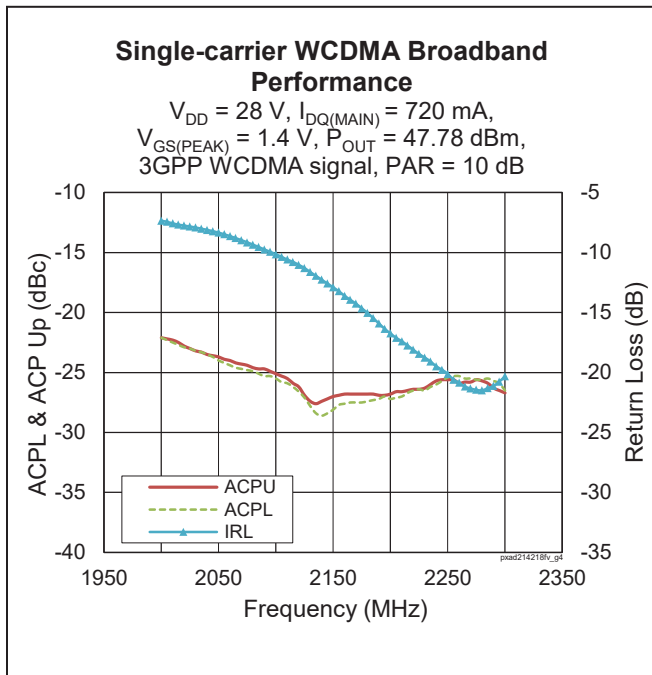
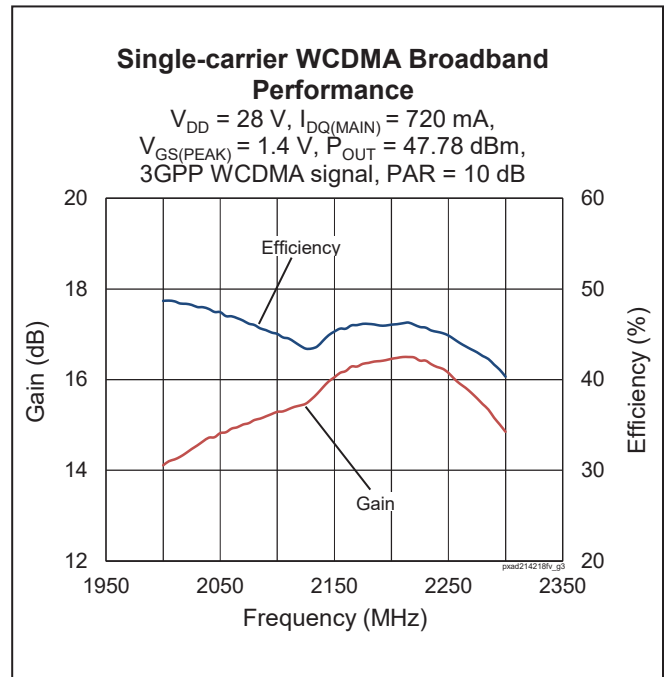
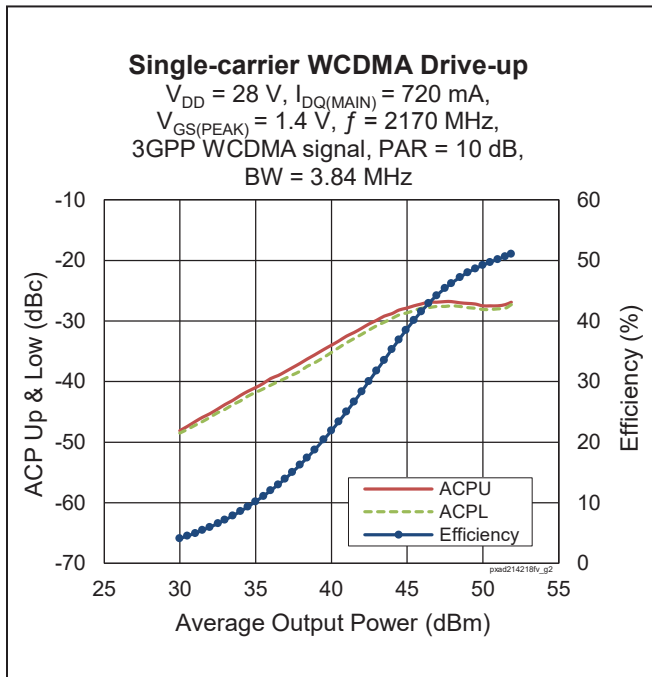



Typical RF Performance (cont.)

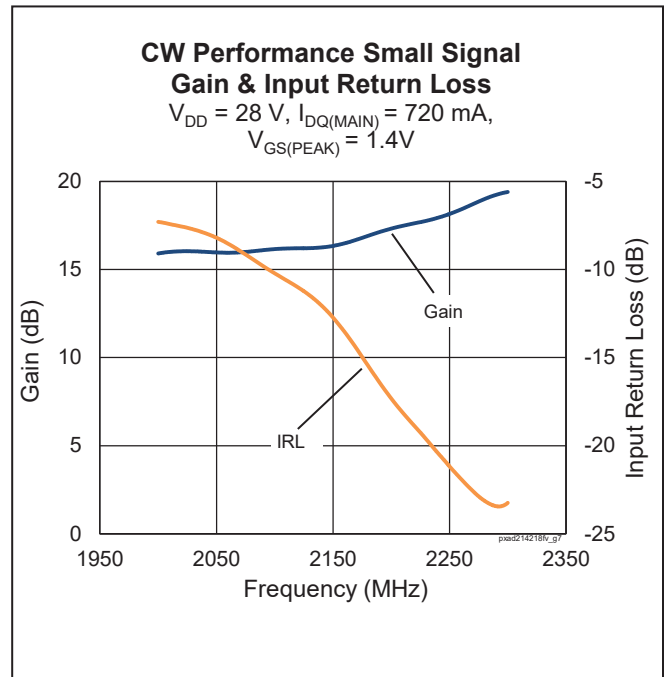
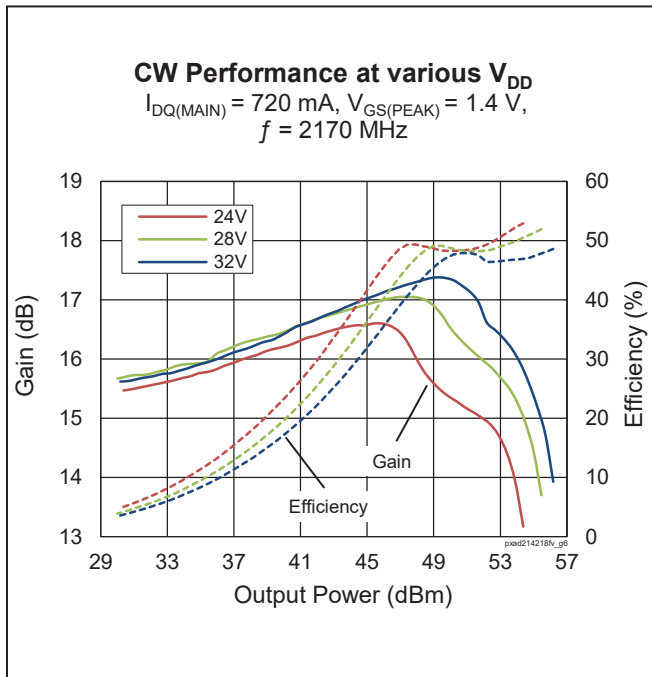

Load Pull Performance

Main Side Load Pull Performance – Pulsed CW signal: 10 μ s, 10% duty cycle, $V_{DD} = 28$ V, $I_{DQ} = 960$ mA, class AB

		P_{1dB}									
		Max Output Power					Max Drain Efficiency				
Freq [MHz]	Zs [Ω]	Zl [Ω]	Gain [dB]	P _{1dB} [dBm]	P _{1dB} [W]	η^D [%]	Zl [Ω]	Gain [dB]	P _{1dB} [dBm]	P _{1dB} [W]	η^D [%]
2110	3.7 - j8.1	1.4 - j3.7	19.7	52.58	181	57.3	2.7 - j3.1	21.7	51.21	132	65.8
2140	5.2 - j8.0	1.5 - j3.8	20.4	52.53	179	59.2	2.4 - j3.2	22	51.40	138	65.5
2170	7.2 - j9.5	1.4 - j3.8	19.7	52.60	182	57.7	2.2 - j3.1	21.5	51.43	139	65.1

		P_{3dB}									
		Max Output Power					Max Drain Efficiency				
Freq [MHz]	Zs [Ω]	Zl [Ω]	Gain [dB]	P _{1dB} [dBm]	P _{1dB} [W]	η^D [%]	Zl [Ω]	Gain [dB]	P _{1dB} [dBm]	P _{1dB} [W]	η^D [%]
2110	3.7 - j8.1	1.4 - j3.8	17.6	53.26	212	58.4	2.7 - j3.0	19.8	51.79	151	67.1
2140	5.2 - j8.0	1.4 - j4.0	17.8	53.22	210	56.7	2.6 - j3.0	20.2	51.76	150	67.4
2170	7.2 - j9.5	1.5 - j4.2	17.7	53.28	213	59.4	2.5 - j2.8	19.9	51.64	146	67.3

Peak Side Load Pull Performance – Pulsed CW signal: 10 μ s, 10% duty cycle, $V_{DD} = 28$ V, $I_{DQ} = 10$ mA, class B

		P_{1dB}									
		Max Output Power					Max Drain Efficiency				
Freq [MHz]	Zs [Ω]	Zl [Ω]	Gain [dB]	P _{1dB} [dBm]	P _{1dB} [W]	η^D [%]	Zl [Ω]	Gain [dB]	P _{1dB} [dBm]	P _{1dB} [W]	η^D [%]
2110	3.0 - j6.2	2.3 - j5.8	16.2	55.39	346	54.0	3.4 - j3.3	17.6	53.62	230	65.2
2140	4.0 - j6.1	2.6 - j6.1	16.6	55.43	349	55.1	3.0 - j3.3	18	53.46	222	65.1
2170	5.0 - j5.3	2.9 - j6.7	16.2	55.33	341	52.8	3.1 - j3.0	17.8	53.00	200	64.9

		P_{3dB}									
		Max Output Power					Max Drain Efficiency				
Freq [MHz]	Zs [Ω]	Zl [Ω]	Gain [dB]	P _{1dB} [dBm]	P _{1dB} [W]	η^D [%]	Zl [Ω]	Gain [dB]	P _{1dB} [dBm]	P _{1dB} [W]	η^D [%]
2110	3.0 - j6.2	2.6 - j6.2	14.1	56.13	410	56.1	3.2 - j3.7	15.7	54.55	285	65.4
2140	4.0 - j6.1	2.8 - j6.6	14.2	56.13	410	55.3	3.4 - j3.9	15.8	54.64	291	65.7
2170	5.0 - j5.3	3.0 - j6.8	14.1	56.03	401	54.7	3.2 - j4.0	15.8	54.59	288	65.0



Reference Circuit, 2110 – 2170 MHz

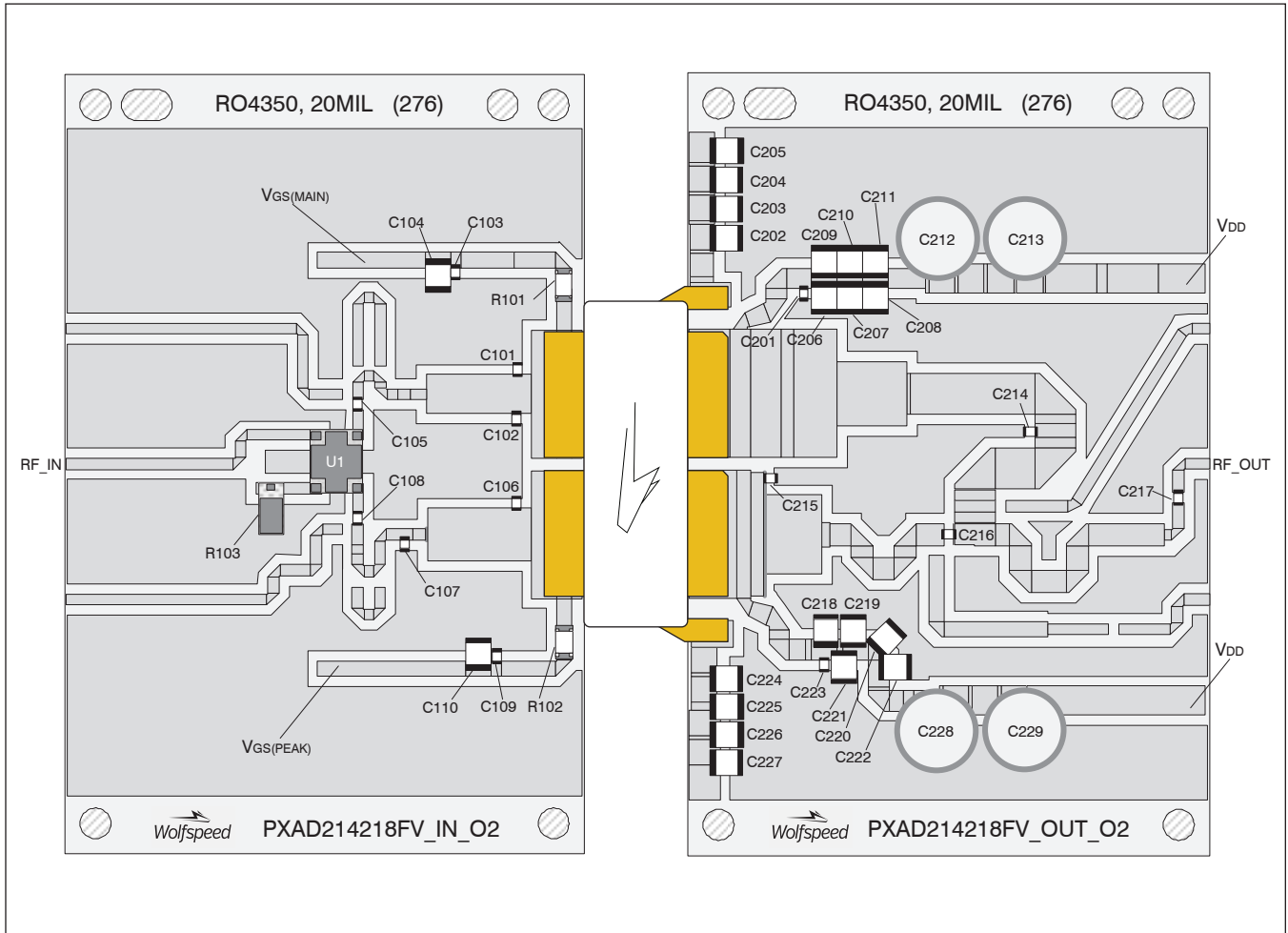

Reference circuit assembly diagram (not to scale)



Reference Circuit (cont.)

Reference Circuit Assembly

DUT	PXAD214218FV V1
Test Fixture Part No.	LTA/PXAD214218FV V1
PCB	Rogers 4350, 0.508 mm [0.020"] thick, 2 oz. copper, $\epsilon_r = 3.66$, $f = 2110 - 2170$ MHz
Find Gerber files for this test fixture on the Wolfspeed Web site at http://www.wolfspeed.com/RF	

Components Information

Component	Description	Manufacturer	P/N
Input			
C101, C102, C106	Capacitor, 0.5 pF	ATC	ATC800A0R5CT250T
C103, C105, C108, C109	Capacitor, 18 pF	ATC	ATC800A180JT250T
C104, C110	Capacitor, 10 μ F	Taiyo Yuden	UMK325C7106MM-T
C107	Capacitor, 0.4 pF	ATC	ATC800A0R4CT250T
R101, R102	Resistor, 5.6 ohms	Panasonic Electronic Components	ERJ-8RQJ5R6V
R103	Resistor, 50 ohms	Richardson	C16A50Z4
U1	Hybrid Coupler	Anaren	X3C21P1-04S
Output			
C201, C216, C217, C223	Capacitor, 18 pF	ATC	ATC800A180JT250T
C202, C203, C204, C205, C206, C207, C208, C209, C210, C211, C218, C219, C220, C221, C222, C224, C225, C226, C227	Capacitor, 10 μ F	Taiyo Yuden	UMK325C7106MM-T
C212, C213, C228, C229	Capacitor, 220 μ F	Panasonic Electronic Components	EEE-FP1V221AP
C214	Capacitor, 0.3 pF	ATC	ATC800A0R3CT250T
C215	Capacitor, 1.2 pF	ATC	ATC800A1R2CT250T

Pinout Diagram (top view)

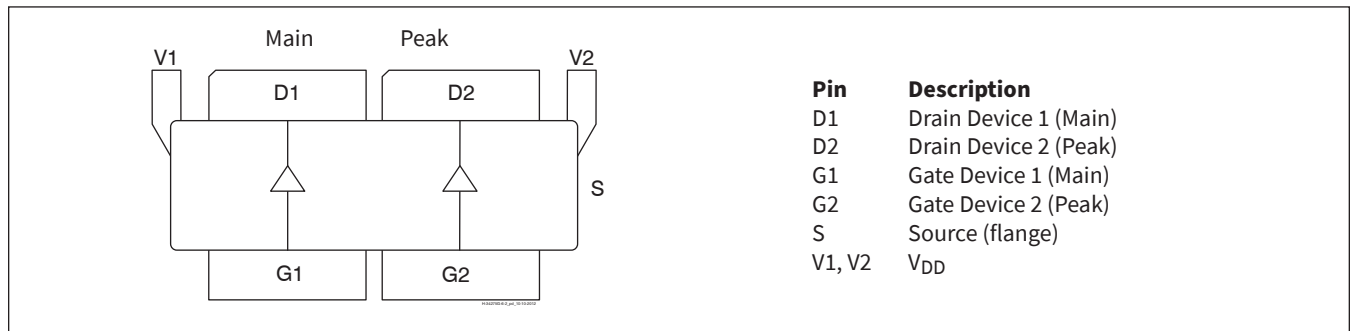

Package Outline Specifications

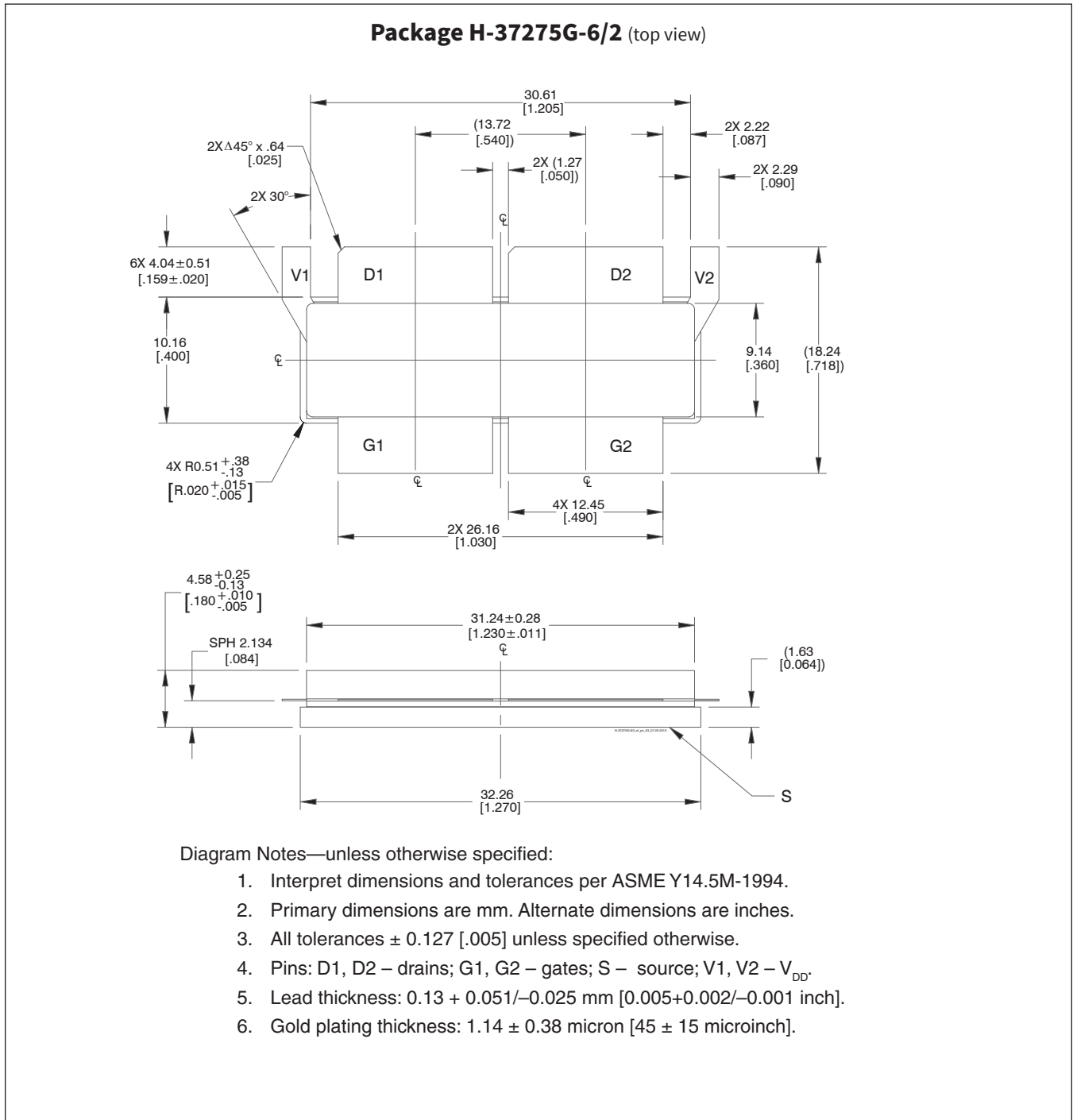

**For more information, please contact:**

4600 Silicon Drive
Durham, NC 27703 USA
Tel: +1.919.313.5300
www.wolfspeed.com/RF

Sales Contact
RFSales@wolfspeed.com

RF Product Marketing Contact
RFMarketing@wolfspeed.com

Notes & Disclaimer

Specifications are subject to change without notice. “Typical” parameters are the average values expected by Wolfspeed in large quantities and are provided for information purposes only. Wolfspeed products are not warranted or authorized for use as critical components in medical, life-saving, or life-sustaining applications, or other applications where a failure would reasonably be expected to cause severe personal injury or death. No responsibility is assumed by Wolfspeed for any infringement of patents or other rights of third parties which may result from use of the information contained herein. No license is granted by implication or otherwise under any patent or patent rights of Wolfspeed.

© 2023 Wolfspeed, Inc. All rights reserved. Wolfspeed® and the Wolfstreak logo are registered trademarks and the Wolfspeed logo is a trademark of Wolfspeed, Inc.

PATENT: <https://www.wolfspeed.com/legal/patents>

The information in this document is subject to change without notice.