

PTRA097058NB

Thermally-Enhanced High Power RF LDMOS FET
800 W, 48 V, 730 – 960 MHz

Description

The PTRA097058NB is a 800-watt LDMOS FET intended for use in multi-standard cellular power amplifier applications in the 730 to 960 MHz frequency band. Features include input and output matching, high gain and thermally-enhanced package with earless flanges. Manufactured with Wolfspeed's advanced LDMOS process, this device provides excellent thermal performance and superior reliability.

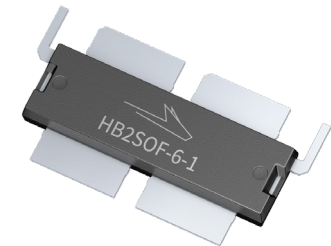

PTRA097058NB
Package PG-HB2SOF-6-1

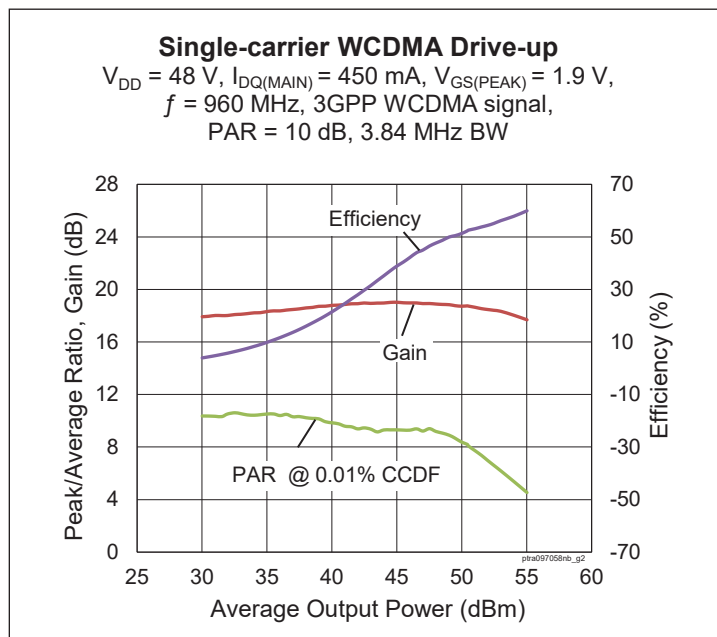

Features

- Broadband internal input and output matching
- Asymmetric design
 - Main: $P_{1dB} = 250\text{ W}$ typical
 - Peak: $P_{1dB} = 500\text{ W}$ typical
- Typical pulsed CW performance, 960 MHz, 48 V, 10 μs , 10% duty cycle, class AB test, Doherty configuration
 - Output power at $P_{1dB} = 630\text{ W}$
 - Output power at $P_{3dB} = 800\text{ W}$
 - Efficiency = 55%
 - Gain = 19 dB
- Capable of handling 10:1 VSWR at 48 V, 112 W (CW) output power
- Integrated ESD protection
- Human Body Model Class 1C (per ANSI/ESDA/JEDEC JS-001)
- Low thermal resistance
- Pb-free and RoHS-compliant

RF Characteristics

Single-carrier WCDMA Specifications (tested in Wolfspeed Doherty test fixture)

$V_{DD} = 48\text{ V}$, $I_{DQ} = 450\text{ mA}$, $P_{OUT} = 112\text{ W}$ avg, $V_{GS(peak)} = 1.9\text{ V}$, $f = 960\text{ MHz}$, 3GPP signal, channel bandwidth = 3.84 MHz, peak/average = 10 dB @ 0.01% CCDF

Characteristics	Symbol	Min	Typ	Max	Unit
Gain	G_{ps}	17.3	18.4	—	dB
Drain Efficiency	η_D	45	48	—	%
Adjacent Channel Power Ratio	ACPR	—	-30	-26.5	dBc
Output PAR @ 0.01% CCDF	OPAR	6.5	7.5	—	dB

All published data at TCASE = 25°C unless otherwise indicated

ESD: Electrostatic discharge sensitive device—observe handling precautions!



DC Characteristics

Characteristics	Conditions	Symbol	Min	Typ	Max	Unit
Drain-source Breakdown Voltage	$V_{GS} = 0\text{ V}, I_{DS} = 10\text{ mA}$	$V_{(BR)DSS}$	105	—	—	V
Drain Leakage Current	$V_{DS} = 48\text{ V}, V_{GS} = 0\text{ V}$	I_{DSS}	—	—	1	μA
	$V_{DS} = 105\text{ V}, V_{GS} = 0\text{ V}$		—	—	10	μA
Gate Leakage Current	$V_{GS} = 10\text{ V}, V_{DS} = 0\text{ V}$	I_{GSS}	—	—	1	μA
On-State Resistance (main)	$V_{GS} = 10\text{ V}, V_{DS} = 0.1\text{ V}$	$R_{DS(on)}$	—	0.07	—	Ω
	$V_{GS} = 10\text{ V}, V_{DS} = 0.1\text{ V}$		—	0.04	—	Ω
Operating Gate Voltage (main)	$V_{DS} = 48\text{ V}, I_{DQ} = 450\text{ mA}$	V_{GS}	3.3	3.55	3.8	V
	$V_{DS} = 48\text{ V}, I_{DQ} = 0\text{ mA}$		—	1.9	—	V

Maximum Ratings

Parameter	Symbol	Value	Unit
Drain-source Voltage	V_{DSS}	105	V
Gate-source Voltage	V_{GS}	-6 to +12	V
Operating Voltage	V_{DD}	0 to +55	V
Junction Temperature	T_J	225	$^{\circ}\text{C}$
Storage Temperature Range	T_{STG}	-65 to +150	$^{\circ}\text{C}$

1. Operation above the maximum values listed here may cause permanent damage. Maximum ratings are absolute ratings; exceeding only one of these values may cause irreversible damage to the component. Exposure to absolute maximum rating conditions for extended periods may affect device reliability. For reliable continuous operation, the device should be operated within the operating voltage range (V_{DD}) specified above.
 2. Parameters values can be affected by end application and product usage. Values may change over time.

Thermal Characteristics

Characteristics	Symbol	Value	Unit
Thermal Resistance (main, $T_{CASE} = 70\text{ }^{\circ}\text{C}$, 112 W CW)	$R_{\theta JC}$	0.48	$^{\circ}\text{C}/\text{W}$
(peak, $T_{CASE} = 70\text{ }^{\circ}\text{C}$, 457 W CW)	$R_{\theta JC}$	0.204	$^{\circ}\text{C}/\text{W}$

Moisture Sensitivity Level

Level	Test Standard	Package Temperature	Unit
3	IPC/JEDEC J-STD-020	260	$^{\circ}\text{C}$

Ordering Information

Type and Version	Order Code	Package	Shipping
PTRA097058NB V1 R2	PTRA097058NB-V1-R2	PG-HB2SOF-6-1	Tape & Reel, 250 pcs



Typical Performance (data taken in test fixture)

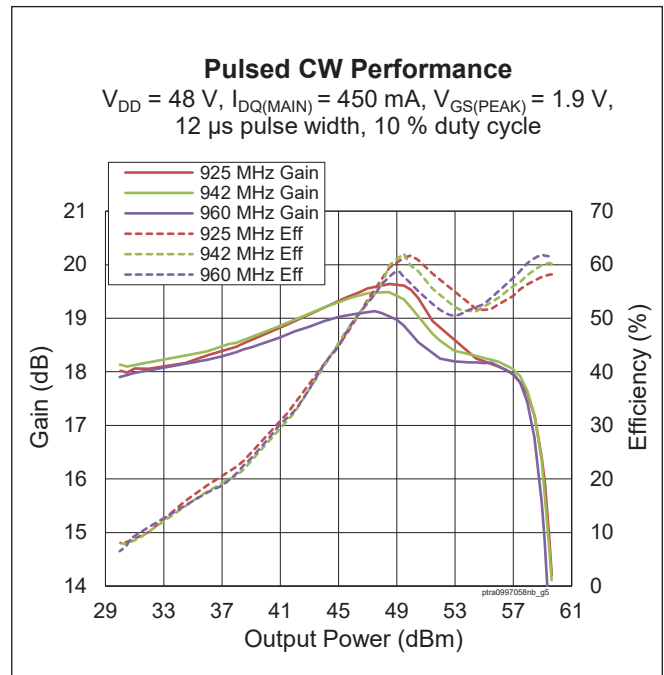
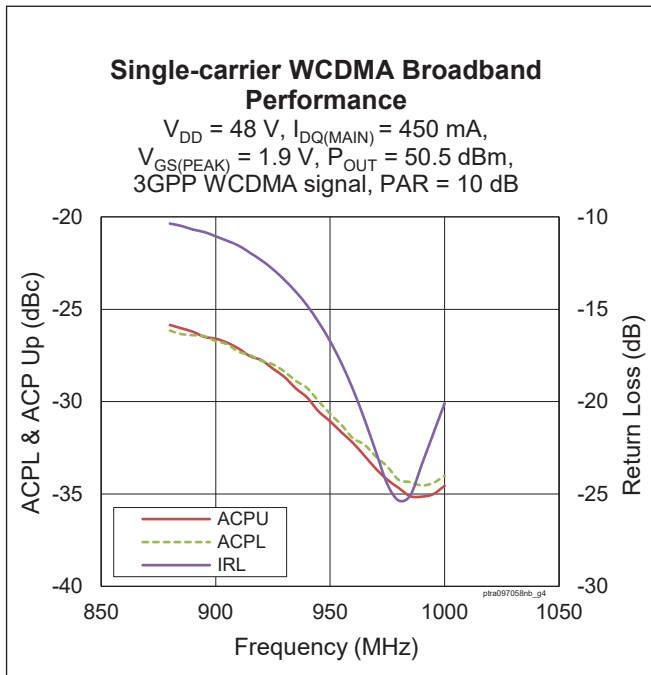
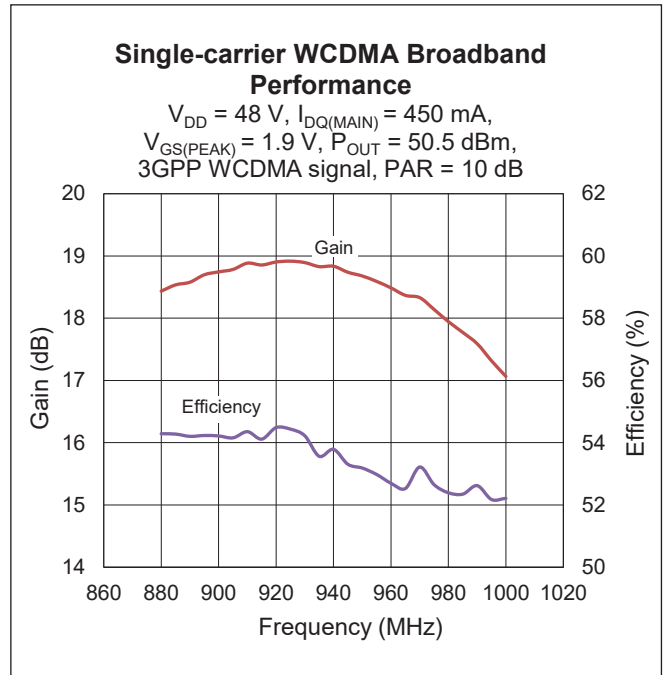
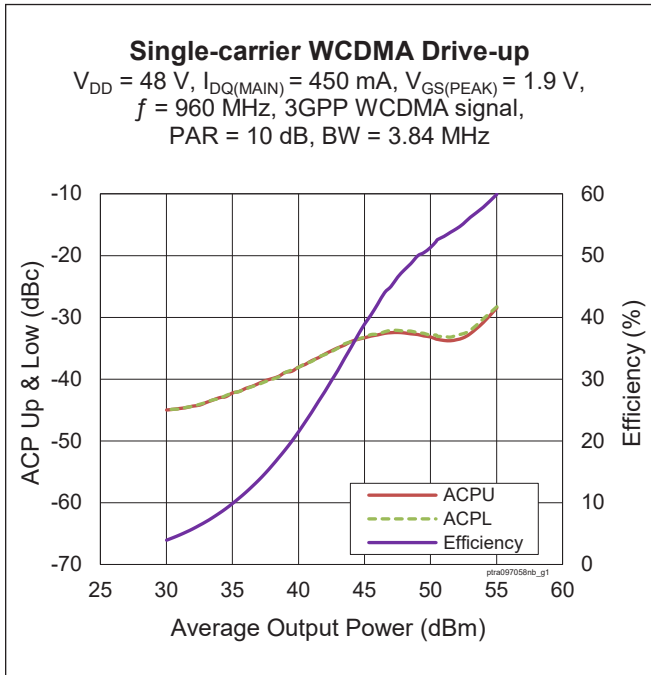

Typical Performance (cont.)

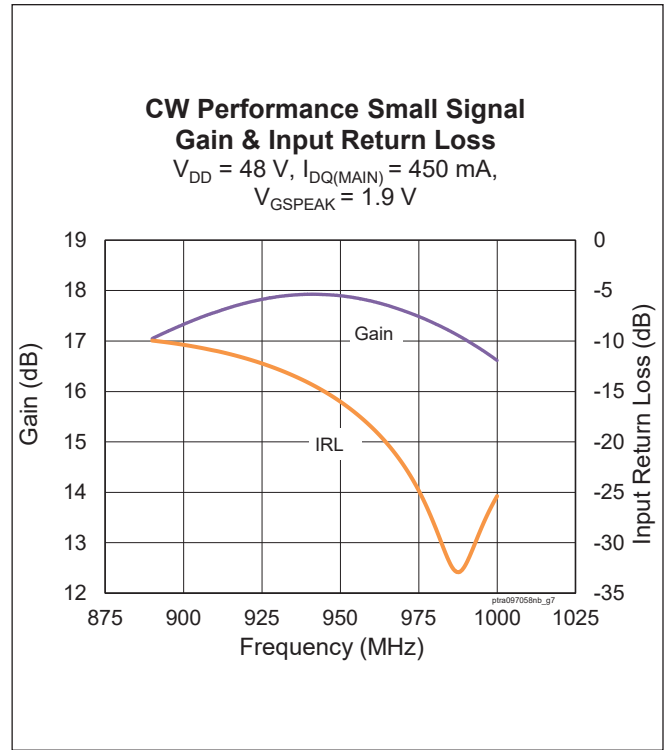
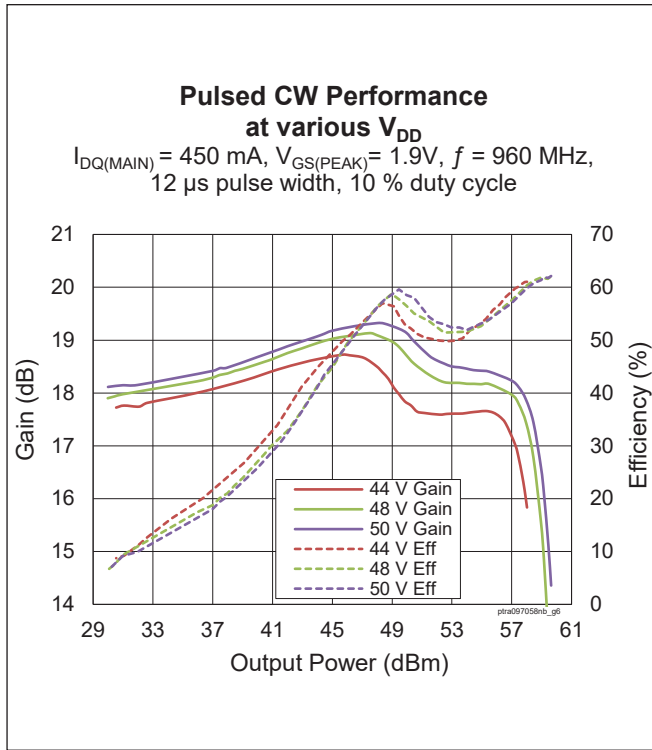

Load Pull Performance

Main Side Load Pull Performance – Pulsed CW signal – 10 μsec, 10% duty cycle, 48 V, IDQ = 450 mA, class AB

		P _{1dB}									
		Max Output Power					Max Drain Efficiency				
Freq [MHz]	Z _s [Ω]	Z _l [Ω]	Gain [dB]	P _{1dB} [dBm]	P _{1dB} [W]	η _D [%]	Z _l [Ω]	Gain [dB]	P _{1dB} [dBm]	P _{1dB} [W]	η _D [%]
760	3.3 + j0.76	2.4 - j0.48	22.08	54.29	268.53	62.2	3.9 + j1.6	23.5	52.60	181.97	73.8
820	2.1 - j1.35	1.7 - j0.14	21.53	54.10	257.04	61.2	3.4 + j2.5	23.26	51.23	132.74	72.3
925	2.2 - j3.3	1.7 - j1.2	20.41	54.27	267.3	57.8	2.2 + j0.7	22.09	52.16	164.44	69.0
960	2.8 - j4	1.6 - j0.9	20.54	54.32	270.4	61.6	1.7 + j1	22.44	51.67	146.89	73.0

		P _{3dB}									
		Max Output Power					Max Drain Efficiency				
Freq [MHz]	Z _s [Ω]	Z _l [Ω]	Gain [dB]	P _{3dB} [dBm]	P _{3dB} [W]	η _D [%]	Z _l [Ω]	Gain [dB]	P _{3dB} [dBm]	P _{3dB} [W]	η _D [%]
760	3.3 + j0.76	2.4 - j0.6	20.03	55.09	322.85	65.6	4.5 + j2.4	21.65	52.48	177.01	75.9
820	2.1 - j1.35	1.7 - j1.1	19.04	55.08	322.11	59.9	2.85 + j0.6	20.8	53.86	243.22	74.8
925	2.2 - j3.3	1.7 - j1.3	18.42	55.11	324.34	60.9	2 + j0.6	20	53.00	199.53	70.9
960	2.8 - j4	1.6 - j1	18.4	55.16	328.1	63.1	1.7 + j0.9	20.36	52.55	179.89	73.2

Peak Side Load Pull Performance – Pulsed CW signal – 10 μsec, 10% duty cycle, 48 V, V_{GSPK} = 2 V, class C

		P _{1dB}									
		Max Output Power					Max Drain Efficiency				
Freq [MHz]	Z _s [Ω]	Z _l [Ω]	Gain [dB]	P _{1dB} [dBm]	P _{1dB} [W]	η _D [%]	Z _l [Ω]	Gain [dB]	P _{1dB} [dBm]	P _{1dB} [W]	η _D [%]
760	0.8 - j0.4	0.87 - j0.7	18.88	57.94	622.3	62.5	0.54 + j0.4	19.87	53.88	244.3	75.6
820	0.7 - j1.55	0.85 - j0.57	18.27	57.74	594.3	60.8	0.55 + j0.39	19.27	54.47	279.9	74.2
925	1.15 - j3.13	0.83 - j0.55	17.18	57.62	578.1	61.0	0.53 + j0.32	17.79	54.56	285.8	73.9
960	1.66 - j3.68	0.8 - j0.63	16.76	57.54	567.5	59.1	0.55 + j0.1	17.87	55.26	335.7	72.9

		P _{3dB}									
		Output					Max Drain Efficiency				
Freq [MHz]	Z _s [Ω]	Z _l [Ω]	Gain [dB]	P _{3dB} [dBm]	P _{3dB} [W]	η _D [%]	Z _l [Ω]	Gain [dB]	P _{3dB} [dBm]	P _{3dB} [W]	η _D [%]
760	0.8 - j0.4	0.89 - j0.72	16.81	58.64	731.1	64.4	0.84 + j0.07	17.83	56.86	485.3	74.9
820	0.7 - j1.55	0.88 - j0.63	16.15	58.46	701.5	62.1	0.54 + j0.22	17.75	55.90	389	74.2
925	1.15 - j3.13	0.86 - j0.6	15.06	58.33	680.8	61.7	0.55 + j0.1	16.33	56.24	420.7	72.7
960	1.66 - j3.68	0.9 - j0.67	14.69	58.23	665.3	60.8	0.55 + j0.06	15.93	56.00	398.1	72.4

Reference Circuit, 760 – 960 MHz

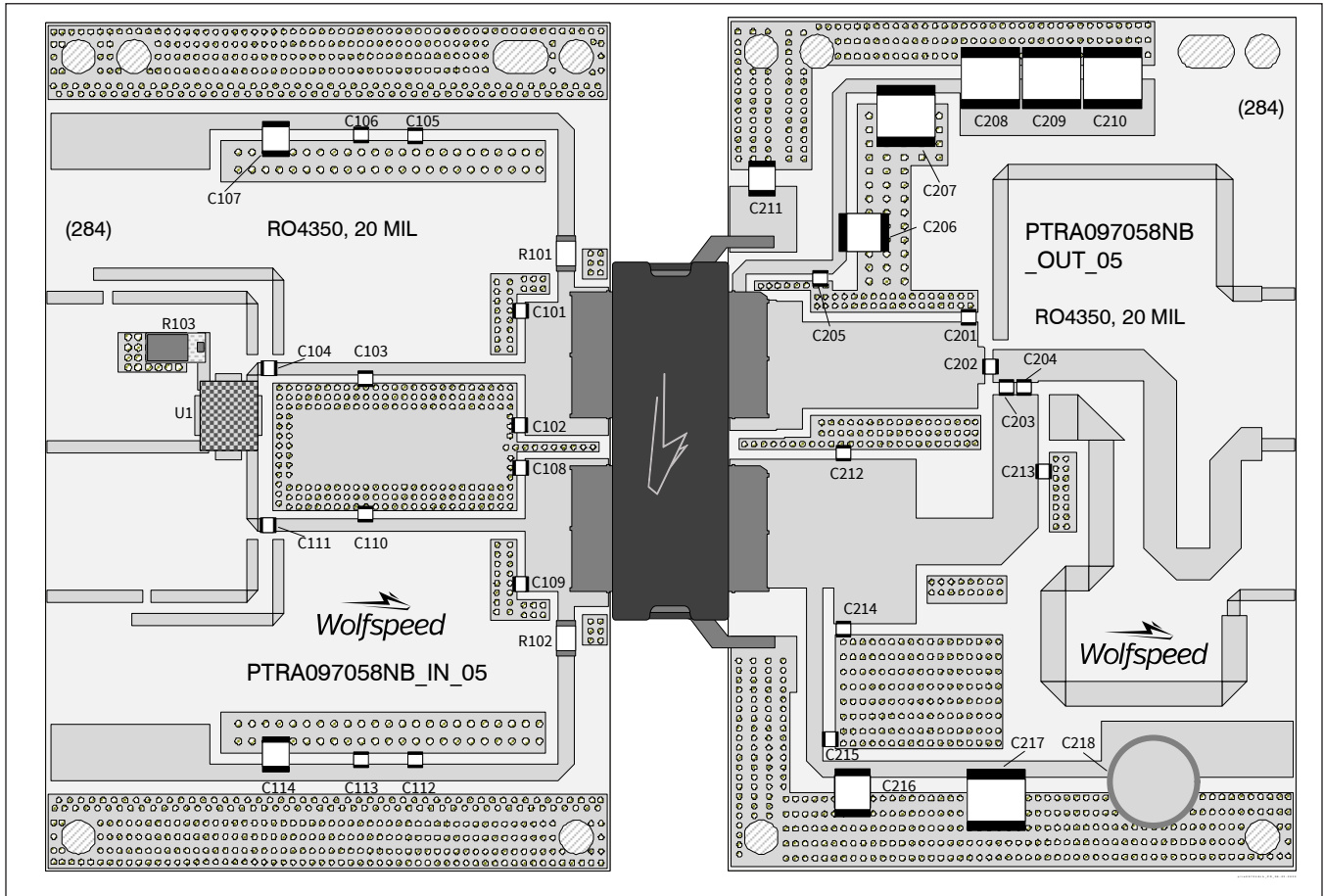

Reference circuit assembly diagram (not to scale)



Reference Circuit Assembly

DUT	PTRA097058NB V1
Test Fixture Part No.	LTA/PTRA097058NB-V1
PCB	Rogers 4350, 0.020” thick, 2 oz. copper, $\epsilon_r = 3.66$, $f = 760 - 960$ MHz
Find Gerber files for this test fixture on the Wolfspeed Web site at www.wolfspeed.com/RF	

Components Information

Component	Description	Manufacturer	P/N
Input			
C101, C102	Capacitor, 8.2 pF	ATC	ATC600F8R2CT250X
C103	Capacitor, 4.3 pF	ATC	ATC600F4R3BT250X
C104, C105, C111, C112	Capacitor, 68 pF	ATC	ATC600F680JT250X
C106, C113	Capacitor, 1 μ F, 6.3 V	Murata Electronics	GRM188R60J105KA01D
C107, C114	Capacitor, 10 μ F, 100 V	Murata Electronics	GRM32EC72A106KE05L
C108, C109	Capacitor, 12 pF	ATC	ATC600F120JT250X
C110	Capacitor, 4.7 pF	ATC	ATC600F4R7BT250X
R101, R102	Resistor, 10 ohms	Panasonic Electronic Components	ERJ-8GEYJ100V
R103	Resistor, 50 ohms	RICHARDSON	C16A50Z4
U1	Hybrid Coupler	RJ2	CMX09Q02
Output			
C201, C214	Capacitor, 6.2 pF	ATC	ATC600F6R2CT250X
C202	Capacitor, 12 pF	ATC	ATC600F120JT250X
C203, C204	Capacitor, 33 pF	ATC	ATC600F330JT250X
C205, C215	Capacitor, 68 pF	ATC	ATC600F680JT250X
C206, C216	Capacitor, 1 μ F, 100 V	TDK Corporation	C4532X7R2A105M230KA
C207, C208, C209, C210, C217	Capacitor, 10 μ F, 100 V	TDK Corporation	C5750X7S2A106M230KB
C211	Capacitor, 10 μ F, 100 V	Murata Electronics	GRM32EC72A106KE05L
C212	Capacitor, 15 pF	ATC	ATC600F150JT250X
C213	Capacitor, 1.5 pF	ATC	ATC600F1R5CT250X
C218	Capacitor, 100 μ F, 63 V	Panasonic Electronic Components	EEE-FK1J101P

Pinout Diagram (top view)

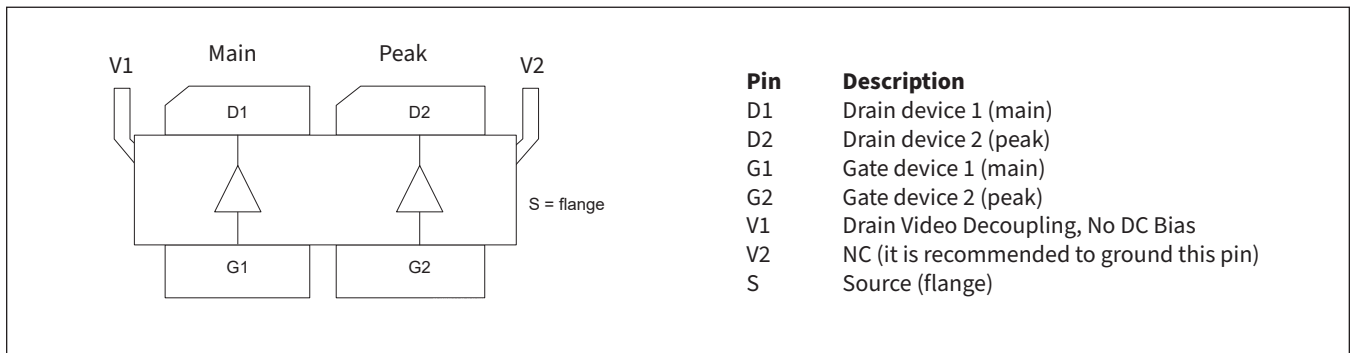

Package Outline Specifications

Package PG-HB2SOF-6-1

TOP VIEW

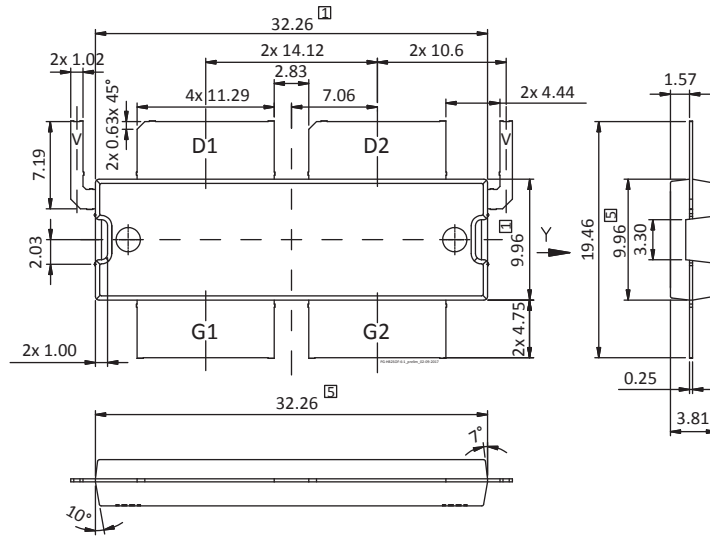

BOTTOM VIEW

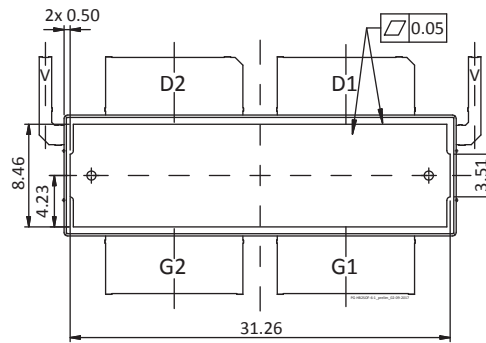

Diagram Notes—unless otherwise specified:

1. Mold/dam bar/metal protrusion of 0.30 mm max per side not included.
2. Fillets and radii: all radii are 0.3 mm max.
3. Interpret dimensions and tolerances per ISO 8015.
4. Dimensions are mm.
5. Does not include mold/dam bar and metal protrusion.
6. All tolerances ± 0.1 mm unless specified otherwise.
7. All metal surfaces tin pre-plated, except area of cut.
8. Lead thickness: 0.25 mm.
9. Pins : D1, D2 – drain; G1, G2 – gate; V1 – drain video decoupling, no DC bias; V2 – NC (it is recommended to ground this pin); S – source

**For more information, please contact:**

4600 Silicon Drive
Durham, NC 27703 USA
Tel: +1.919.313.5300
www.wolfspeed.com/RF

Sales Contact
RFSales@wolfspeed.com

RF Product Marketing Contact
RFMarketing@wolfspeed.com

Notes & Disclaimer

Specifications are subject to change without notice. “Typical” parameters are the average values expected by Wolfspeed in large quantities and are provided for information purposes only. Wolfspeed products are not warranted or authorized for use as critical components in medical, life-saving, or life-sustaining applications, or other applications where a failure would reasonably be expected to cause severe personal injury or death. No responsibility is assumed by Wolfspeed for any infringement of patents or other rights of third parties which may result from use of the information contained herein. No license is granted by implication or otherwise under any patent or patent rights of Wolfspeed.

© 2023 Wolfspeed, Inc. All rights reserved. Wolfspeed® and the Wolfstreak logo are registered trademarks and the Wolfspeed logo is a trademark of Wolfspeed, Inc.
PATENT: <https://www.wolfspeed.com/legal/patents>

The information in this document is subject to change without notice.