

Wire Pins

Non-Insulated Wire Pins

Material: Tin Plated Copper
Maximum Electrical Rating: 176°C, 600V
Barrel Type: Brazed Seam

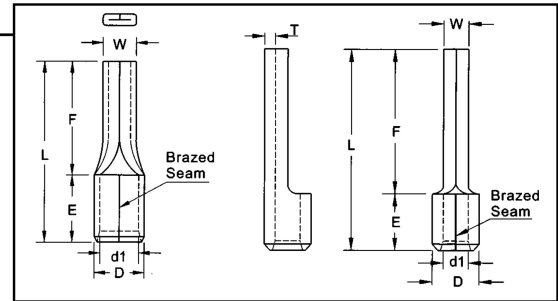

T= Material Thickness

HOFFMAN PART NO.	WIRE SIZE	AMPS	DIMENSIONS (INCHES)								UL	TAPE MOUNTED REEL QTY	DIE FOR TAPE MOUNT	HAND TOOL
			W	F	L	E	D	d1	T					
PC2216	22-16	9 - 18	0.075	0.472	0.661	0.189	0.134	0.067	0.030	Y	NA	NA	YHM228	
PC2216/J	22-16	9 - 18	0.075	0.472	0.669	0.197	0.134	0.063	0.031	N	NA	NA	YHT2210	
PC1614	16-14	18 - 30	0.075	0.512	0.701	0.189	0.161	0.091	0.031	Y	NA	NA	YHM228	
PC1614/J	16-14	18 - 30	0.075	0.472	0.669	0.197	0.161	0.091	0.031	N	NA	NA	YHT2210	
PC1210	12-10	35 - 50	0.110	0.551	0.787	0.236	0.220	0.134	0.037	Y	NA	NA	YHM228	
PC1210/J	12-10	35 - 50	0.106	0.551	0.787	0.236	0.224	0.142	0.039	N	NA	NA	YHT2210	

Vinyl Insulated Wire Pins

Material: Tin Plated Copper
Insulation: Vinyl
Maximum Electrical Rating: 75°C, 600V
Barrel Type: Butted Seam

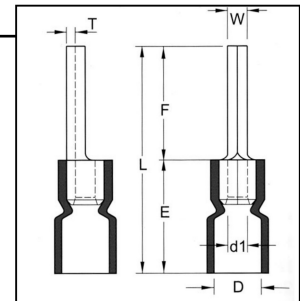

T= Material Thickness

HOFFMAN PART NO.	WIRE SIZE	AMPS	DIMENSIONS (INCHES)								UL	TAPE MOUNT REEL QTY	DIE FOR TAPE MOUNT	HAND TOOL
			W	F	L	E	D	d1	T					
FVLP2216R2	22-16	9 - 18	0.472	0.075	0.906	0.441	0.157	0.067	0.030	Y	1000	3V2216	YNM2210	
FVLP2216R2/J	22-16	9 - 18	0.472	0.075	0.827	0.354	0.157	0.067	0.031	Y	NA	NA	YNT2216	
FVLP1614	16-14	18 - 30	0.472	0.075	0.917	0.453	0.177	0.091	0.031	Y	1000	3V1614	YNM2210	
FVLP1614/J	16-14	18 - 30	0.472	0.075	0.827	0.354	0.177	0.091	0.031	Y	NA	NA	YNT1614	
FVLP1210	12-10	35 - 50	0.551	0.110	1.106	0.555	0.248	0.134	0.039	Y	500	3V1210	YNM2210	
FVLP1210/J	12-10	35 - 50	0.551	0.106	1.083	0.531	0.268	0.134	0.039	Y	NA	NA	YNT1210S	

