

- 1
- 2
- 3
- 4
- 5
- 6
- 7
- 8
- 9
- 10
- 11
- 12
- 13
- 14
- 15
- 16
- 17
- 18

**MATERIAL**

High-resilience polypropylene based (PP) technopolymer, black colour, matte finish.

Technopolymer centre cap, black colour, matte finish. Not available for VCT.25.

Elastic fork in acetal based technopolymer (POM), black colour.

**RETAINING CHAIN**

Ball cable and coupling heads in acetal resin based (POM) technopolymer, black colour.

NERINOX treated stainless steel ring with two coils.

Head fastening by means of a self-tapping screw  $\varnothing 4.8$  mm UNI EN ISO 7050 or a M5 countersunk-head screw UNI EN ISO 10642.

**STANDARD EXECUTIONS**

- **VCT-B-LP**: brass boss, threaded pass-through hole.
- **VCT-p-LP**: zinc-plated steel threaded stud chamfered flat end according to UNI 947: ISO 4753 (see Technical data on page A-10).

**FEATURES AND APPLICATIONS**

The elastic fork, housed in the groove of the knob can turn freely. The coiled ring connects the fork to the chain.

Suitable where it is necessary to prevent the loss of the knob.

**SPECIAL EXECUTIONS ON REQUEST**

- Chain in different lengths.
- Knob with stainless steel cable GN 111 on page 934, GN 111.2 on page 935 and GN 111.4 on page 936.



ELESA Original design

VCT-B-LP

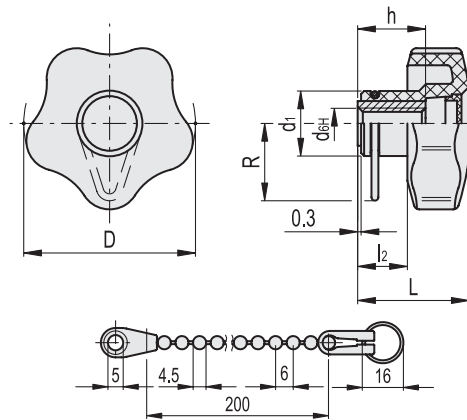

Conversion Table	
1 mm = 0.039 inch	
D	
mm	inch
25	0.98
32	1.26
40	1.57
50	1.97
63	2.48

**VCT-B-LP**

METRIC

Code	Description	D	d8H	L	d1	l2	h	R	C# [Nm]	⚖️
69512-C9	VCT.25 B-M5-LP-C9	25	M5	19	13	8	10	20	7	10
69544-C9	VCT.32 B-M6-LP-C9	32	M6	23	15	10	12	21	10	14
69594-C9	VCT.40 B-M8-LP-C9	40	M8	27	17	12	18	21.5	18	24
69654-C9	VCT.50 B-M10-LP-C9	50	M10	32	19	14	20	22.5	27	34
69714-C9	VCT.63 B-M12-LP-C9	63	M12	37	22	16	26	24	50	44

# "Max limit Tightening torque" means the max torque value at which the metal insert, in normal conditions of use, is perfectly and strongly anchored to the plastic material.

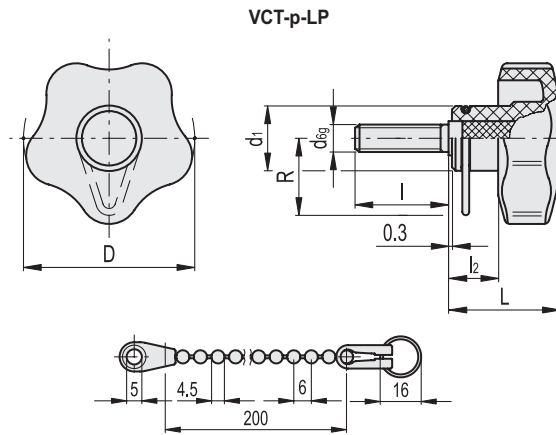

Conversion Table	
1 mm = 0.039 inch	
D	
mm	inch
25	0.98
32	1.26
40	1.57
50	1.97
63	2.48

VCT-p-LP

METRIC

Code	Description	D	d6g	L	d1	l	l2	R	C# [Nm]	⚖
69521-C9	VCT.25 p-M5x10-LP-C9	25	M5	19	13	10	8	20	6	9
69522-C9	VCT.25 p-M5x16-LP-C9	25	M5	19	13	16	8	20	6	10
69523-C9	VCT.25 p-M5x20-LP-C9	25	M5	19	13	20	8	20	6	11
69524-C9	VCT.25 p-M5x25-LP-C9	25	M5	19	13	25	8	20	6	12
69551-C9	VCT.32 p-M6x16-LP-C9	32	M6	23	15	16	10	21	8	15
69552-C9	VCT.32 p-M6x20-LP-C9	32	M6	23	15	20	10	21	8	16
69553-C9	VCT.32 p-M6x25-LP-C9	32	M6	23	15	25	10	21	8	17
69554-C9	VCT.32 p-M6x30-LP-C9	32	M6	23	15	30	10	21	8	18
69612-C9	VCT.40 p-M8x20-LP-C9	40	M8	27	17	20	12	21.5	16	26
69613-C9	VCT.40 p-M8x25-LP-C9	40	M8	27	17	25	12	21.5	16	28
69614-C9	VCT.40 p-M8x30-LP-C9	40	M8	27	17	30	12	21.5	16	29
69616-C9	VCT.40 p-M8x40-LP-C9	40	M8	27	17	40	12	21.5	16	32
69671-C9	VCT.50 p-M10x20-LP-C9	50	M10	32	19	20	14	22.5	23	38
69672-C9	VCT.50 p-M10x25-LP-C9	50	M10	32	19	25	14	22.5	23	41
69673-C9	VCT.50 p-M10x30-LP-C9	50	M10	32	19	30	14	22.5	23	43
69675-C9	VCT.50 p-M10x40-LP-C9	50	M10	32	19	40	14	22.5	23	48
69733-C9	VCT.63 p-M12x30-LP-C9	63	M12	37	22	30	16	24	46	69
69735-C9	VCT.63 p-M12x40-LP-C9	63	M12	37	22	40	16	24	46	75
69736-C9	VCT.63 p-M12x50-LP-C9	63	M12	37	22	50	16	24	46	82

# "Max limit Tightening torque" means the max torque value at which the metal insert, in normal conditions of use, is perfectly and strongly anchored to the plastic material.