

MATERIAL

Deburred and mirror-polished cast aluminium.

STANDARD EXECUTIONS

H7 reamed blind hole or threaded blind hole.



ELESA Original design

- 1
- 2
- 3
- 4
- 5
- 6
- 7
- 8
- 9
- 10
- 11
- 12
- 13
- 14
- 15
- 16
- 17
- 18

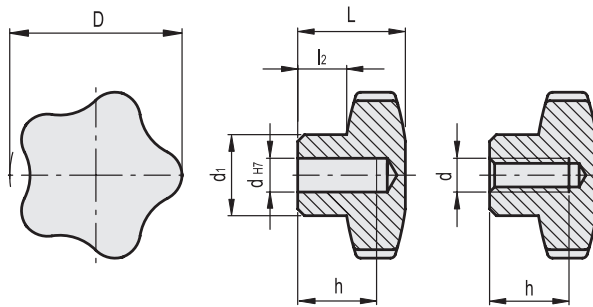

Conversion Table	
1 mm = 0.039 inch	
D	
mm	inch
40	1.57
50	1.97
60	2.36
70	2.76

METRIC

Code	Description	D	d	dH7	L-1	d1-0.5	l2	hmin.	⚖
169521	VCM.40-8	40	-	8	25	15	12.5	15	28
169522	VCM.40-M8	40	M8	-	25	15	12.5	15	28
169526	VCM.50-10	50	-	10	32	19	16	18	53
169527	VCM.50-M10	50	M10	-	32	19	16	18	54
169531	VCM.60-12	60	-	12	40	21	20	22	92
169532	VCM.60-M12	60	M12	-	40	21	20	22	88
169536	VCM.70-16	70	-	16	46	26	23	28	142
169537	VCM.70-M16	70	M16	-	46	26	23	28	142

Clamping knobs