

- 1
- 2
- 3
- 4
- 5
- 6
- 7
- 8
- 9
- 10
- 11
- 12
- 13
- 14
- 15
- 16
- 17
- 18

MATERIAL

High-strength, reinforced phenolic based (PF) Duroplast, black colour, glossy finish.

STANDARD EXECUTION

Black-oxide steel hub, uncovered front end with pre-drilled pass-through hole.

Maximum permissible diameter 16mm.

ACCESSORIES ON REQUEST

Axial retaining washer GN 184 (see page 677).

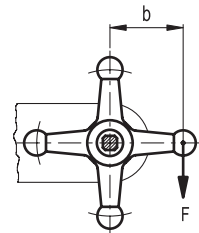
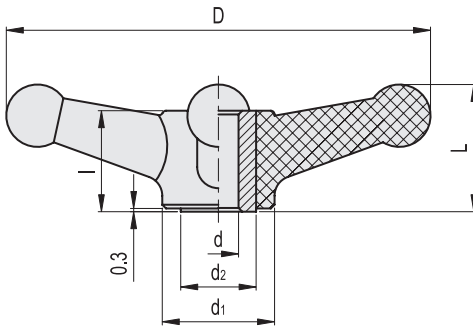

$$C [Nm] = F [N] \cdot b [m]$$

| Conversion Table | |
|-------------------|------|
| 1 mm = 0.039 inch | |
| D | |
| mm | inch |
| 170 | 6.69 |

METRIC

| Code | Description | D | dH9 | L | d1 | d2 | l | C# [Nm] | |
|-------|-------------|-----|-----|----|----|----|----|---------|-----|
| 65001 | VB.198/170 | 170 | 12 | 50 | 45 | 20 | 40 | 105 | 327 |

2 # For maximum applicable torque (C) see Technical data on page A-3.