

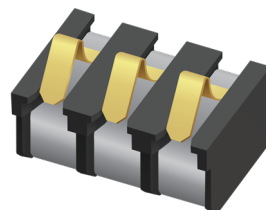

# Specialty Connectors

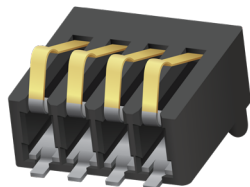
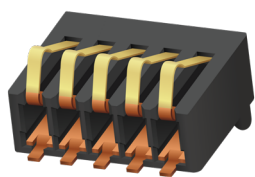

## IMPORTANT INFORMATION/DISCLAIMER

All product specifications, statements, information and data (collectively, the “Information”) in this datasheet or made available on the website are subject to change. The customer is responsible for checking and verifying the extent to which the Information contained in this publication is applicable to an order at the time the order is placed. All Information given herein is believed to be accurate and reliable, but it is presented without guarantee, warranty, or responsibility of any kind, expressed or implied.

Statements of suitability for certain applications are based on KYOCERA AVX knowledge of typical operating conditions for such applications, but are not intended to constitute and KYOCERA AVX specifically disclaims any warranty concerning suitability for a specific customer application or use.

**ANY USE OF PRODUCT OUTSIDE OF SPECIFICATIONS OR ANY STORAGE OR INSTALLATION INCONSISTENT WITH PRODUCT GUIDANCE VOIDS ANY WARRANTY.**

The Information is intended for use only by customers who have the requisite experience and capability to determine the correct products for their application. Any technical advice inferred from this Information or otherwise provided by KYOCERA AVX with reference to the use of KYOCERA AVX products is given without regard, and KYOCERA AVX assumes no obligation or liability for the advice given or results obtained.

Although KYOCERA AVX designs and manufactures its products to the most stringent quality and safety standards, given the current state of the art, isolated component failures may still occur. Accordingly, customer applications which require a high degree of reliability or safety should employ suitable designs or other safeguards (such as installation of protective circuitry or redundancies) in order to ensure that the failure of an electrical component does not result in a risk of personal injury or property damage.

Unless specifically agreed to in writing, KYOCERA AVX has not tested or certified its products, services or deliverables for use in high risk applications including medical life support, medical device, direct physical patient contact, water treatment, nuclear facilities, weapon systems, mass and air transportation control, flammable environments, or any other potentially life critical uses. Customer understands and agrees that KYOCERA AVX makes no assurances that the products, services or deliverables are suitable for any high-risk uses. Under no circumstances does KYOCERA AVX warrant or guarantee suitability for any customer design or manufacturing process.

Although all product-related warnings, cautions and notes must be observed, the customer should not assume that all safety measures are indicated or that other measures may not be required.

# SPECIALTY CONNECTORS CATALOG



## Table of Contents

### SINGLE-PAIR ETHERNET (SPE) CONNECTOR

IP20 Jack & Cable: 6780-000.....	1
----------------------------------	---

### BATTERY CONNECTORS

Standard 2.5mm Pitch 9155-000.....	4
Ultra-Low Profile 2.5mm Pitch 9155-100.....	16
Reduced 2.5mm Pitch 9155-200.....	22
Right Angle 3.0mm Pitch 9155-300.....	31
Right Angle 2.5mm Pitch 9155-500.....	38
Vertical Mate 2.0mm Pitch 9155-800.....	45

### BATTERY CONTACTS

Single Compression Contact.....	54
---------------------------------	----

### I/O CONNECTORS

Standard I/O, 15 Position, XX-9157.....	57
Standard I/O, 19 Position, XX-9157.....	65
Reduced Size I/O, 16 Position XX-9257.....	68
Mini I/O, 12 Position XX-9257.....	74

### SIM CARD CONNECTORS

SIM BLOCK 9162-000.....	78
Slide-In SIM 9162-200.....	80
Locking SIM 9162-300.....	84
Slide-In Low Profile SIM 9162-400.....	86
SIM/Micro SD Combination 9162-500.....	89

### WTB COAX CONNECTORS

IDC SMT COAX 1 Position 00-9178.....	92
--------------------------------------	----



# SINGLE-PAIR ETHERNET (SPE) CONNECTOR

IP20 Jack & Cable: 6780-000

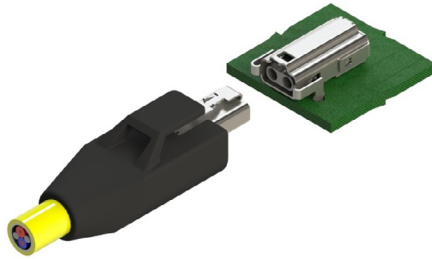

As the Industrial Ethernet market continues to grow, the market keeps looking for smaller and faster connectors to fit their needs. As a result, Single Pair Ethernet has been driven to the forefront of discussion. Single Pair Ethernet (SPE) describes the transmission of Ethernet over only one pair of twisted copper wires. In addition to data transmission via Ethernet, SPE also enables a simultaneous power supply of terminal devices via PoDL – Power over Data Line. Previously, this required two pairs for Fast Ethernet (100MB) and four pairs for Gigabit Ethernet. In addition to space and weight savings with less wire, SPE transmits 1 GBit/s up to a distance of 40 meters. KYOCERA AVX is a part of the SPE Industrial Partner Network and will offer SPE products to meet the customer and market needs while meeting the standards according to IEC 63171-6 and IEEE 802.3 etc.

As a member of the SPE Industrial Partner Network, KYOCERA AVX will be actively involved in the continuing development of single-pair Ethernet (SPE) standards and compatible connectivity products, and will also serve as an ambassador of the significant space- and weight-saving advantages that SPE offers for applications including industrial, process, and building automation systems, smart city networks, and transportation systems.

## APPLICATIONS

- Robotics
- Automation
- Sensor & actuator networks
- Control & monitoring cameras
- Smart grid
- Traffic control
- Transportation Smart Monitoring

## FEATURES AND BENEFITS

- Improved performance over one single twisted pair of wires
- Simplified networks, eliminated gateways
- Industry standard acc. IEC 63171-6
- Transmission speeds from 10Mbit/s to 1Gbit/s
- Transmission ranges up to 1000 meters
- Reliable cold welded KYOCERA AVX IDC technology for signal wires for simple assembly process and easier automation of cabling process
- SMT solder tails for signal wires connection to the PCB

## ELECTRICAL

- Current rating: 4A @60°C
- Voltage rating: 60V DC
- Voltage proof: 1000V DC (contact to contact) & 2250V DC (contact to shield)

## ENVIRONMENTAL

- Operating temperature: -40°C to +85°C
- Storage temperature: -40°C to +70°C
- IP degree protection: IP20

## MECHANICAL

- Mating force: 20N max
- Durability: 1000 cycles / MPL1000
- Polarization force: 50N min
- Pull out force: 50N min

SPE IP20 Product performances comply with IEC 63171-6 requirements

## HOW TO ORDER – SPE IP20 JACK (STYLE 2J-L PER IEC 63171-6)

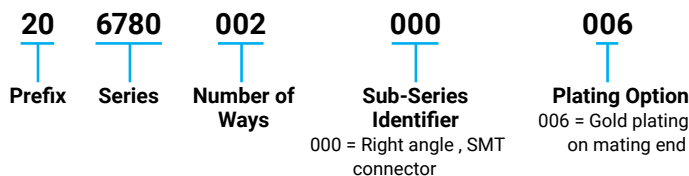

## HOW TO ORDER – SPE IP20 PLUG (STYLE 2P-L PER IEC 63171-6) CABLE ASSEMBLY

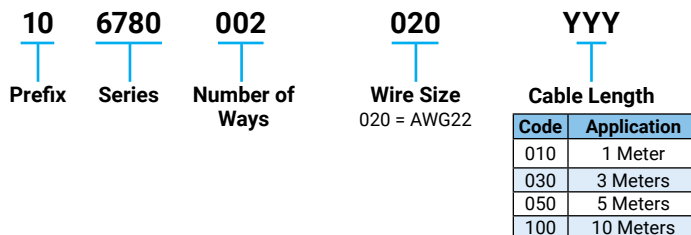

Other length available upon request



# SINGLE-PAIR ETHERNET (SPE) CONNECTOR

IP20 Jack: 6780-000



20-6780-002-000-006

## SPE IP20 JACK (2J-L), RIGHT ANGLE

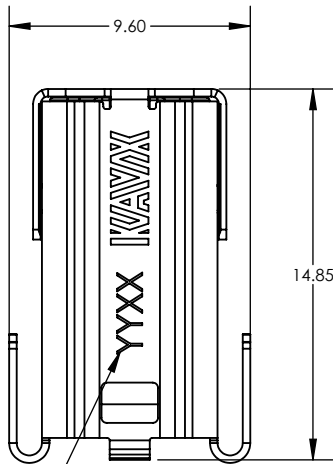

ASSEMBLY DATE CODE  
YY = YEAR  
XX = CALENDAR WEEK

### NOTES

- DESIGNED IN ACCORDANCE WITH IEC 63171-6.
  - MPL1000
  - COMPATIBLE WITH 10BASE-T1, 100BASE-T1, AND 1000BASE-T1
- MATERIALS:
  - CONTACTS: COPPER ALLOY WITH NICKEL UNDERPLATE OVER ALL, GOLD PLATING ON MATING END, TIN PLATING ON PCB END.
  - EMI SHIELD: STAINLESS STEEL WITH NICKEL PLATING OVER ALL.
  - HOUSING: ENGINEERED THERMOPLASTIC, UL94V-0 FLAMMABILITY RATING, COLOR: BLACK
- OPERATING TEMPERATURE: -40°C TO +85°C.
- ELECTRICAL CHARACTERISTICS:
  - VOLTAGE RATING:  $\leq 60\text{VDC}$
  - CURRENT-CARRYING CAPACITY: 4A

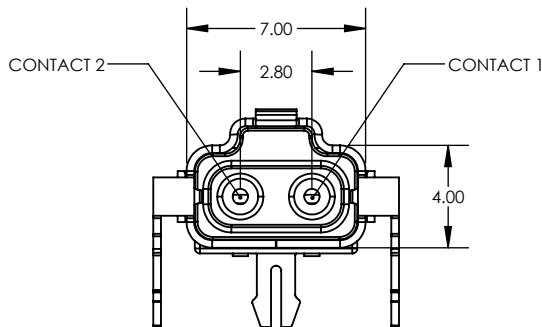
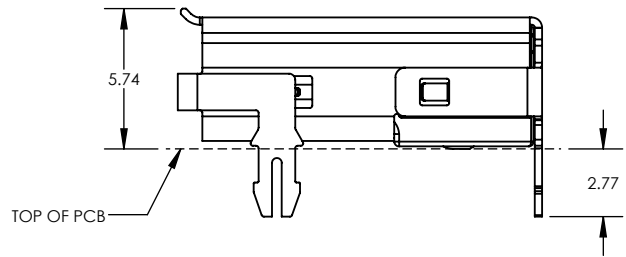

Contact No.	Signal
1	BL_DA +
2	BL_DA -

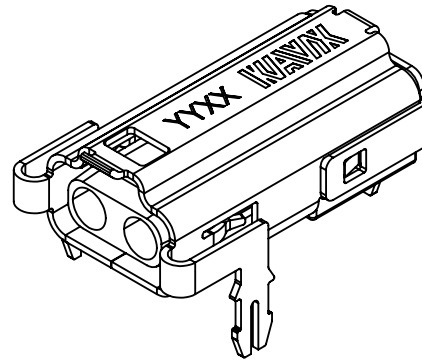

### RECOMMENDED PCB LAYOUT

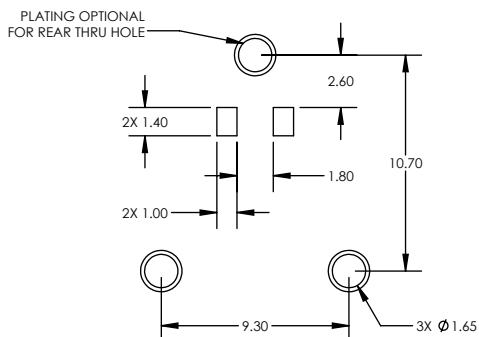

### RECOMMENDED PANEL CUTOUT

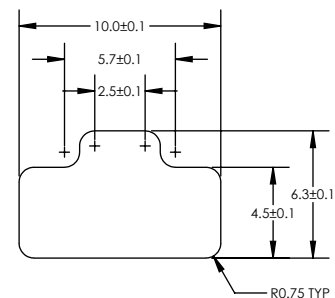

# SINGLE-PAIR ETHERNET (SPE) CONNECTOR

IP20 Jack: 6780-020

10-6780-002-020-XXX

## SPE IP20 PLUG (2P-L), CABLE ASSEMBLY

### NOTES

1. DESIGNED IN ACCORDANCE WITH IEC 63171-6
  - MPL1000
  - COMPATIBLE WITH 10BASE-T1, 100BASE-T1, AND 1000BASE-T1
2. MATERIALS:
  - CONTACTS: COPPER ALLOY WITH NICKEL UNDERPLATE OVER ALL, GOLD PLATING ON MATING END.
  - EMI SHIELDS: STAINLESS STEEL WITH NICKEL PLATING OVER ALL.
  - HOUSINGS: ENGINEERED THERMOPLASTIC, UL94V-0 FLAMMABILITY RATING,
  - COLOR: BLACK.
  - CABLE: 22 AWG STRANDED
3. OPERATING TEMPERATURE: -40°C TO +80°C.
4. ELECTRICAL CHARACTERISTICS:
  - VOLTAGE RATING:  $\leq 60\text{VDC}$
  - CURRENT-CARRYING CAPACITY: 4A

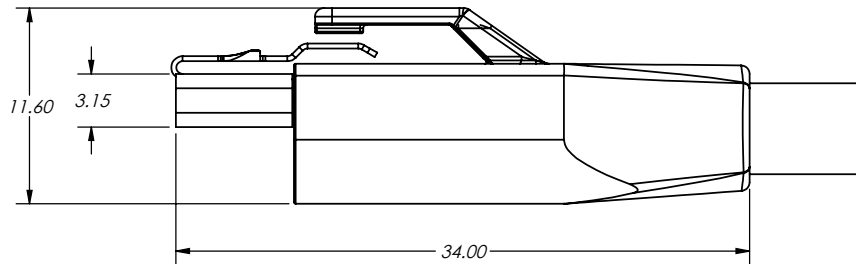
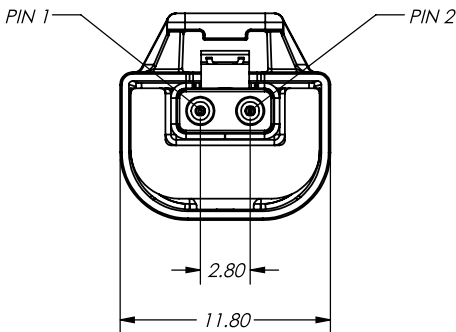
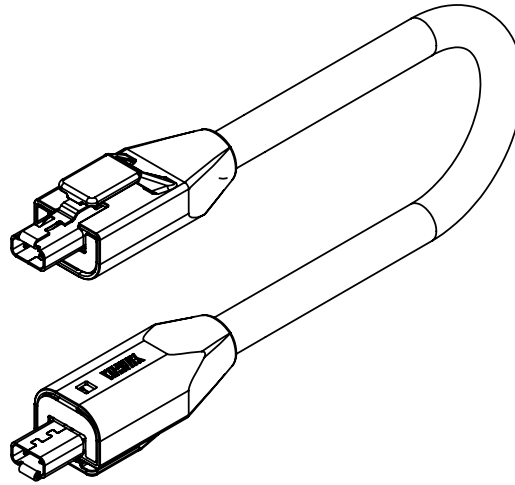
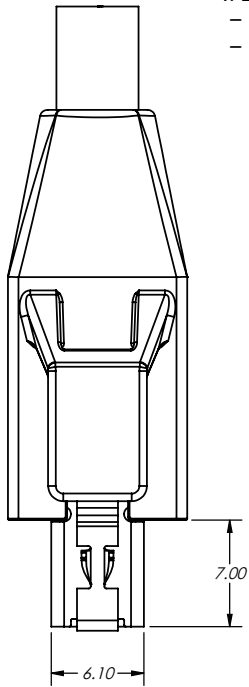

Pin No.	Signal
1	BI_DA +
2	BI_DA -

# BATTERY CONNECTORS

## Standard 2.5mm Pitch 9155-000

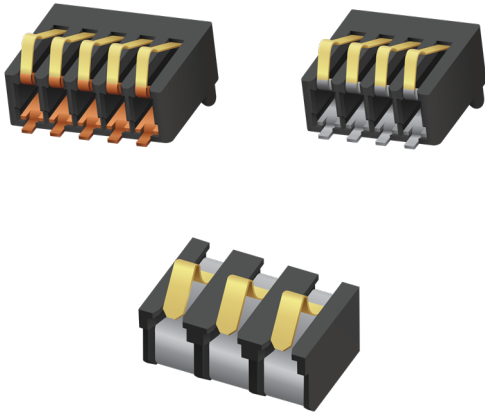

The standard battery connector is specifically designed for mobile equipment.

The connectors are available in 3, 4 and 5 contact positions all on a 2.50mm pitch. The insulator height provides a 3mm spacing, with various contact nose heights from 1.20mm to 2.60mm, to provide spacing options to the end user.

All contacts are stamped and are rated to 3A, with Gold plating. Parts are supplied in tape and reel for automatic pick and place. Optional retaining brackets are available to provide greater strength when connected to the PCB.

Whatever your requirements, the 9155 series Battery Connector can also be customized to suit your applications.

### APPLICATIONS

- Mobile Phones
- PDA
- Medical
- PMR
- Industrial

### FEATURES AND BENEFITS

- Suitable for 5000 mechanical cycles.
- Variety of contact heights offered to suit different mechanical designs.
- Connectors can be end to end stackable.
- RoHS Compliant available.

### ELECTRICAL

- Current Rating: 3 Amp / Contact
- Voltage Rating: 125 VAC

### ENVIRONMENTAL

- Operating Temperature: -40°C to +125°C

### MECHANICAL

- Insulator Material: Glass-Filled Nylon 46; UL94 V-0
- Contact Material: Beryllium Copper
- Plating: Gold over Nickel
- Durability: 5000 Cycles

### HOW TO ORDER

#### STANDARD



<b>00</b>	<b>9155</b>	<b>00X</b>	<b>00</b>	<b>X</b>	<b>01</b>	<b>X</b>
Prefix	Series	No of Ways	Standard Battery Connector	Contact Height	Bracket	Plating Option
00 = Standard 58 = Special		3 = 003 4 = 004 5 = 005	00 = Standard Force	1 = 1.20 (0.047) / 1.65 (0.064) 2 = 1.80 (0.071) / 2.10 (0.083) 3 = 2.30 (0.091) / 2.60 (0.102)	01 = With Bracket	6 = 0.4µm Selective Gold, Standard 8 = 0.8µm Selective Gold, Special Order

#### REDUCED NOSE

<b>00</b>	<b>9155</b>	<b>00X</b>	<b>05</b>	<b>X</b>	<b>01</b>	<b>X</b>
Prefix	Series	No of Ways	Standard Battery Connector	Contact Height	Bracket	Plating Option
00 = Standard 58 = Special		3 = 003 4 = 004 5 = 005	05 = Reduced Nose	1 = 1.20 (0.047) / 1.50 (0.059) 2 = 1.80 (0.071) / 2.10 (0.083) 3 = 2.30 (0.091) / 2.60 (0.102)	01 = With Bracket	6 = 0.4µm Selective Gold, Standard 8 = 0.8µm Selective Gold, Special Order

# BATTERY CONNECTORS

## Standard 2.5mm Pitch 9155-000

### 3 WAY BATTERY CONNECTOR

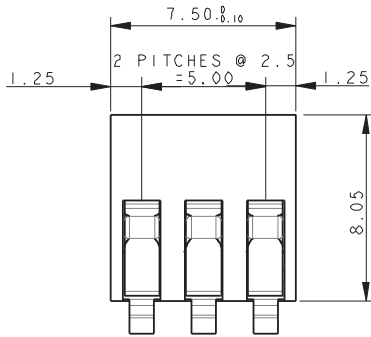

#### NOTES:

1. FOR MORE INFORMATION REFER TO PRODUCT SPEC 201-01-050.
2. GENERAL TOLERANCE  $\pm 0.20$  UNLESS OTHERWISE STATED.
3. FOR MATING PAD DETAILS REFER TO PAGE 6.
4. INSULATOR MATERIAL: 30% GLASS FILLED NYLON 46, UL94 V-O. COLOR BLACK.
5. CONTACT MATERIAL: BERYLLIUM COPPER.
6. CONTACT PLATING: SELECTIVE GOLD OVER NICKEL. PURE TIN ON TAILS.
7. BRACKET MATERIAL: PHOSPHOR BRONZE.
8. BRACKET PLATING: PURE TIN OVER NICKEL.

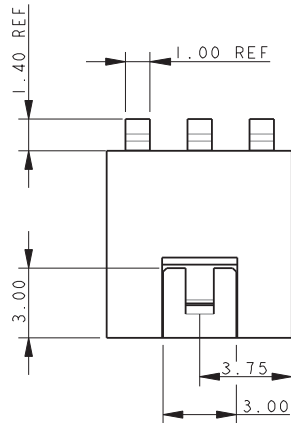
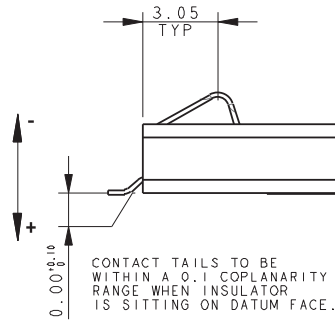
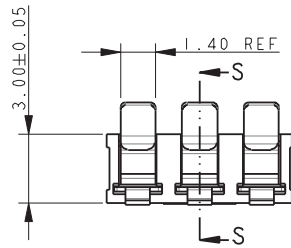

### MATING CONDITIONS

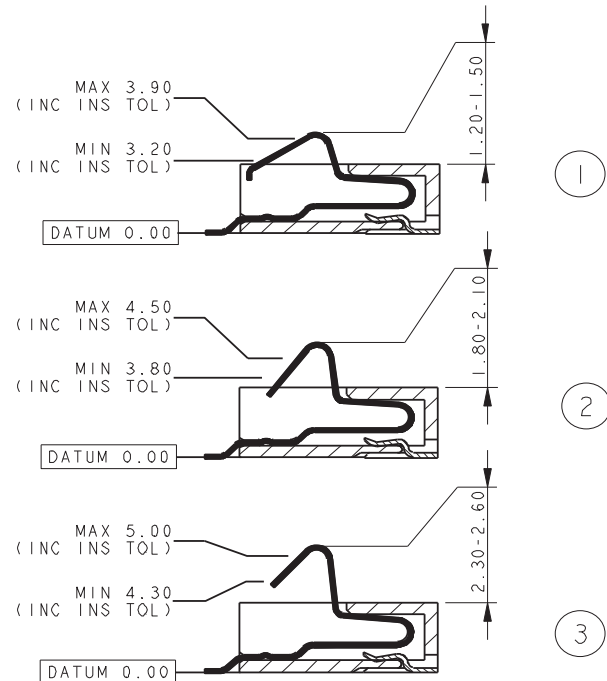

### PCB BOARD LAYOUT

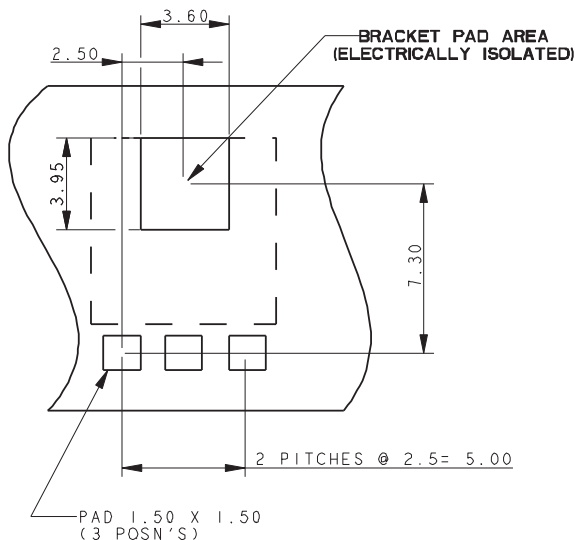

### PACKING DETAILS

REEL QTY	1000
LEADER	500MM
TRAILER	500MM
REEL / BOX	5

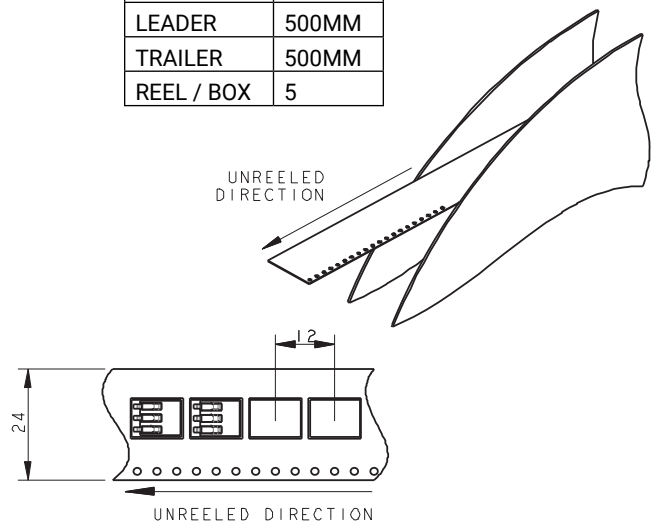



# BATTERY CONNECTORS

## Standard 2.5mm Pitch 9155-000



### 4 WAY BATTERY CONNECTOR

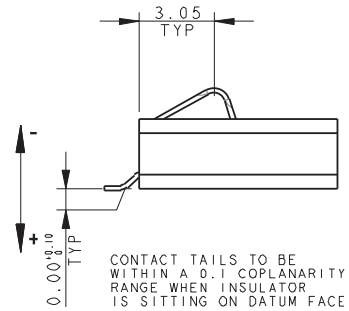
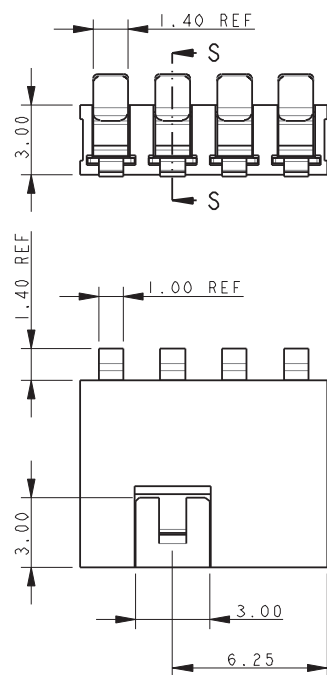
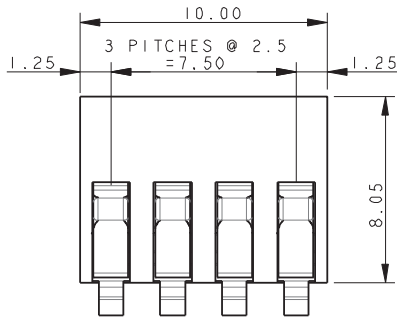

CONTACT TAILS TO BE WITHIN A 0.1 COPLANARITY RANGE WHEN INSULATOR IS SITTING ON DATUM FACE.

#### NOTES:

1. FOR MORE INFORMATION REFER TO PRODUCT SPEC 201-01-050.
2. GENERAL TOLERANCE  $\pm 0.20$  UNLESS OTHERWISE STATED.
3. FOR MATING PAD DETAILS REFER TO PAGE 6.
4. INSULATOR MATERIAL: 30% GLASS FILLED NYLON 46, UL94 V-O. COLOR BLACK.
5. CONTACT MATERIAL: BERYLLIUM COPPER.
6. CONTACT PLATING: SELECTIVE GOLD OVER NICKEL. PURE TIN ON TAILS.
7. BRACKET MATERIAL: PHOSPHOR BRONZE.
8. BRACKET PLATING: PURE TIN OVER NICKEL.

### MATING CONDITIONS

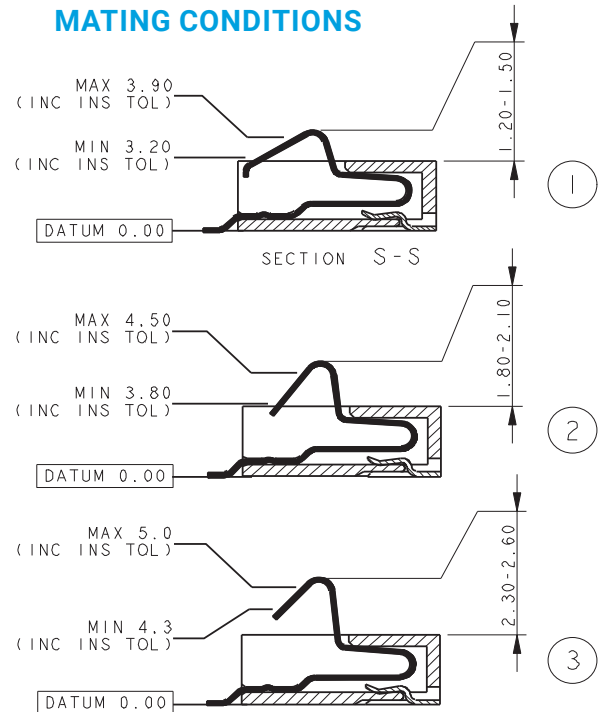

### PCB BOARD LAYOUT

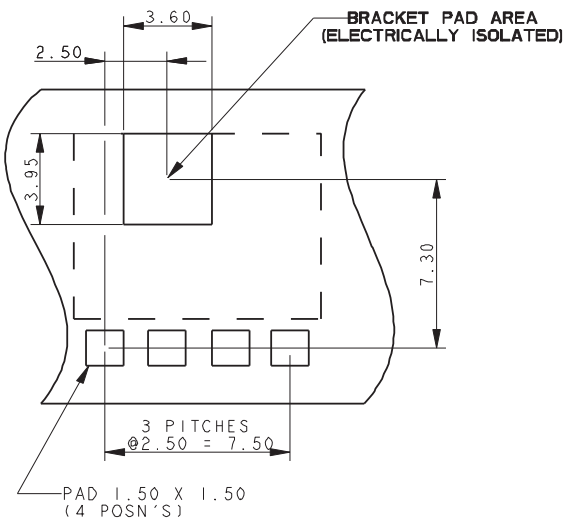

### PACKING DETAILS

REEL QTY	1000
LEADER	500MM
TRAILER	500MM
REEL / BOX	5

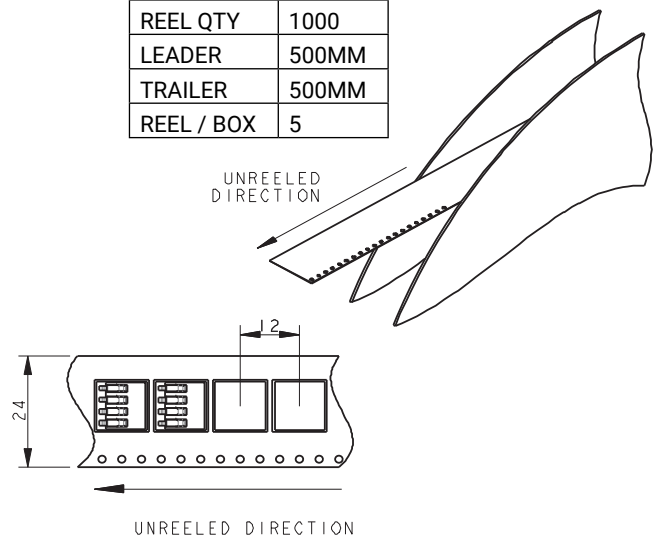

# BATTERY CONNECTORS

## Standard 2.5mm Pitch 9155-000

### 5 WAY BATTERY CONNECTOR

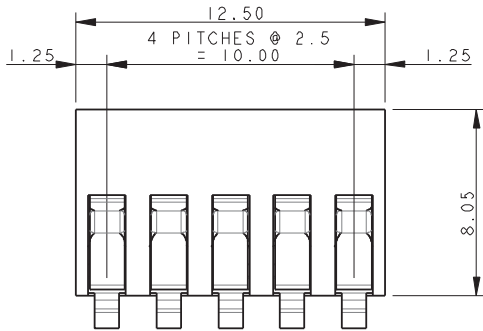

#### NOTES:

1. FOR MORE INFORMATION REFER TO PRODUCT SPEC 201-01-050.
2. GENERAL TOLERANCE  $\pm 0.20$  UNLESS OTHERWISE STATED.
3. FOR MATING PAD DETAILS REFER TO PAGE 6.
4. INSULATOR MATERIAL: 30% GLASS FILLED NYLON 46, UL94 V-0. COLOR BLACK.
5. CONTACT MATERIAL: BERYLLIUM COPPER.
6. CONTACT PLATING: SELECTIVE GOLD OVER NICKEL. PURE TIN ON TAILS.
7. BRACKET MATERIAL: PHOSPHOR BRONZE.
8. BRACKET PLATING: PURE TIN OVER NICKEL.

### MATING CONDITIONS

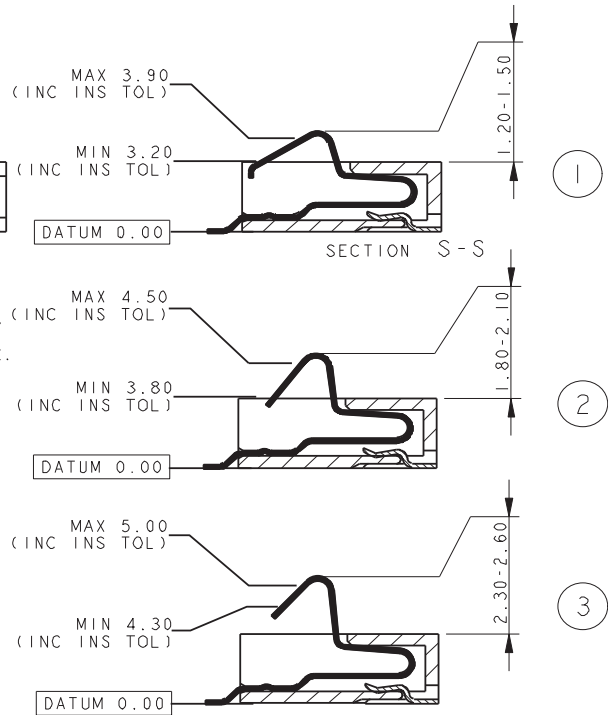
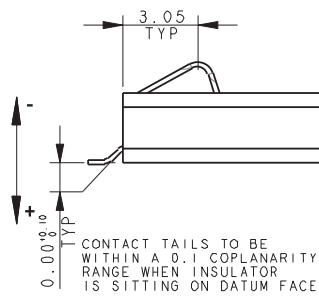
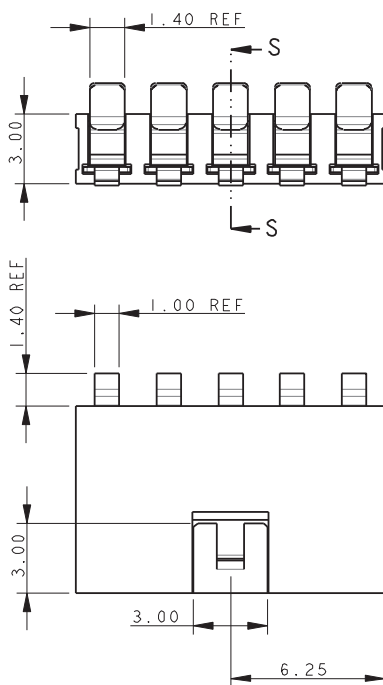

### PCB BOARD LAYOUT

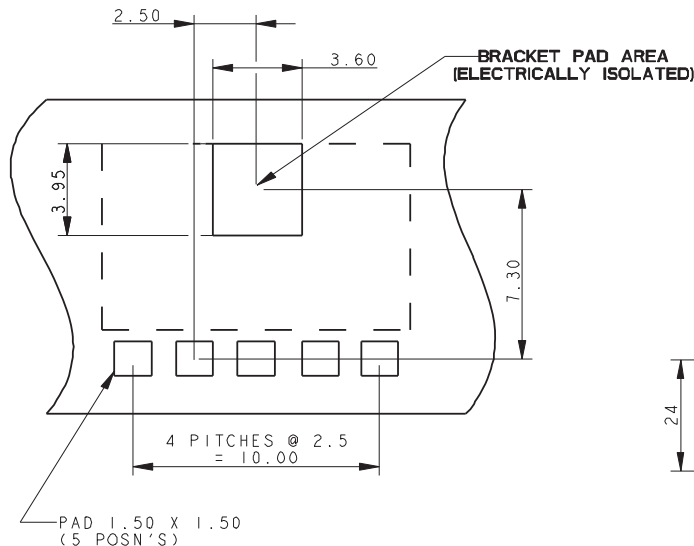

### PACKING DETAILS

REEL QTY	1000
LEADER	500MM
TRAILER	500MM
REEL / BOX	5

UNREEL DIRECTION

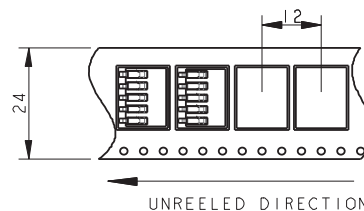

# BATTERY CONNECTORS

Standard 2.5mm Pitch 9155-000

## STANDARD BATTERY – MATING PADS

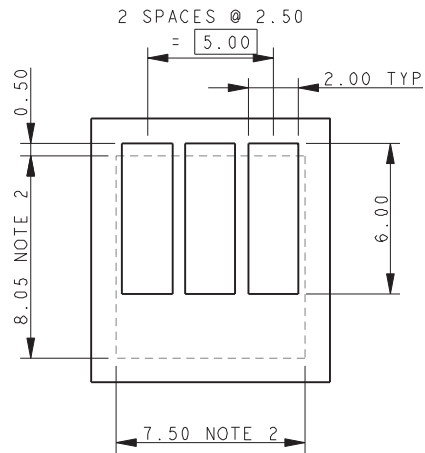

3 WAY MATING PADS

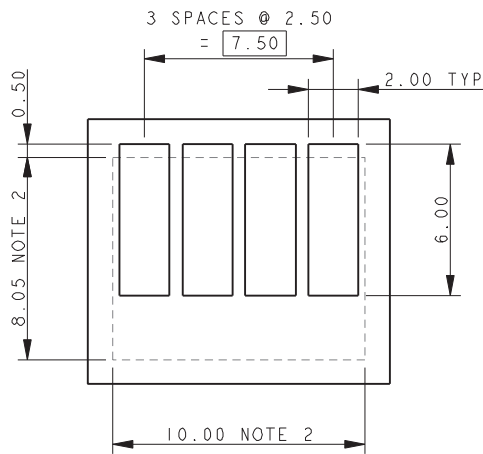

4 WAY MATING PADS

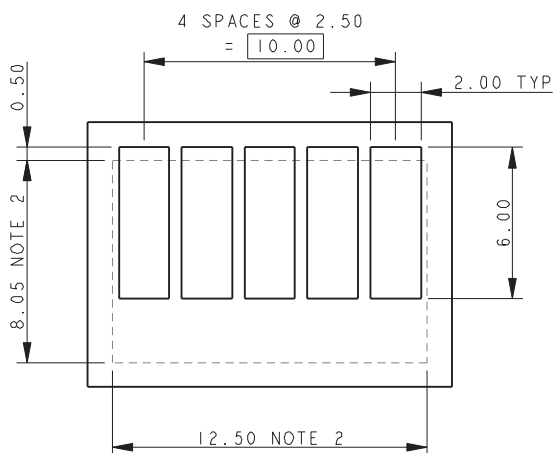

5 WAY MATING PADS

### NOTES:

1. SUGGESTED MATING PADS FOR STANDARD BATTERY CONNECTORS.
2. OUTLINE OF CONNECTOR.
3. PREFERRED PLATING ON PADS GOLD OVER NICKEL.
4. PAD LENGTH MAY REQUIRE ADJUSTMENT OF MATCH THE CUSTOMERS ASSEMBLY.
5. REFERENCE DIMENSIONS.

# BATTERY CONNECTORS

## Standard 2.5mm Pitch 9155-000



### 3 WAY BATTERY CONNECTOR REDUCED NOSE

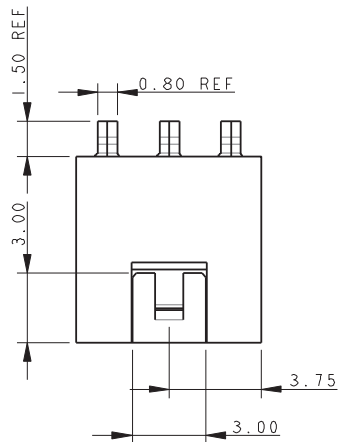
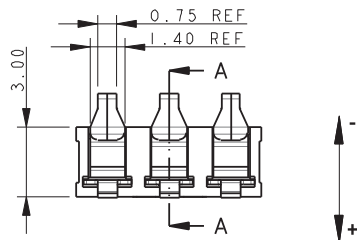
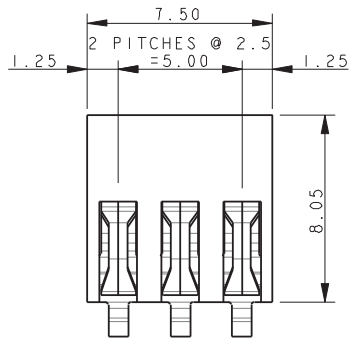

#### NOTES:

1. FOR MORE INFORMATION REFER TO PRODUCT SPEC 201-01-050.
2. GENERAL TOLERANCE  $\pm 0.20$  UNLESS OTHERWISE STATED.
3. FOR MATING PAD DETAILS REFER TO PAGE 9.
4. INSULATOR MATERIAL: 30% GLASS FILLED NYLON 46, UL94 V-0. COLOR BLACK.
5. CONTACT MATERIAL: BERYLLIUM COPPER.
6. CONTACT PLATING: SELECTIVE GOLD OVER NICKEL. PURE TIN ON TAILS.
7. BRACKET MATERIAL: PHOSPHOR BRONZE.
8. BRACKET PLATING: PURE TIN OVER NICKEL.

### MATING CONDITIONS

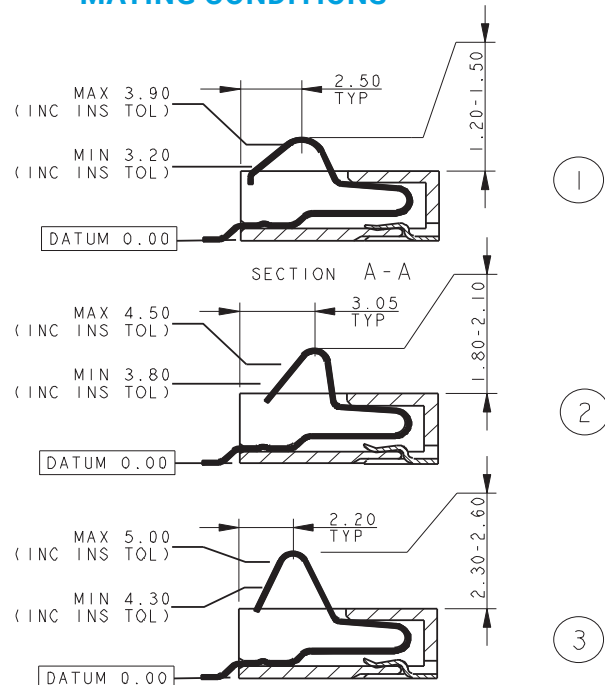

### PCB BOARD LAYOUT

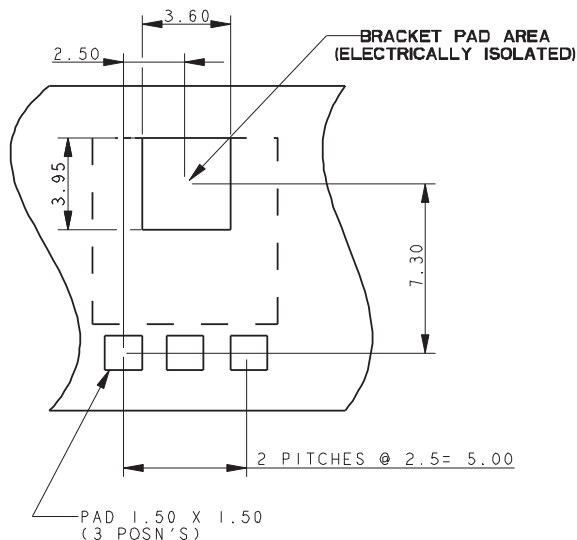

### PACKING DETAILS

REEL QTY	1000
LEADER	500MM
TRAILER	500MM
REEL / BOX	5

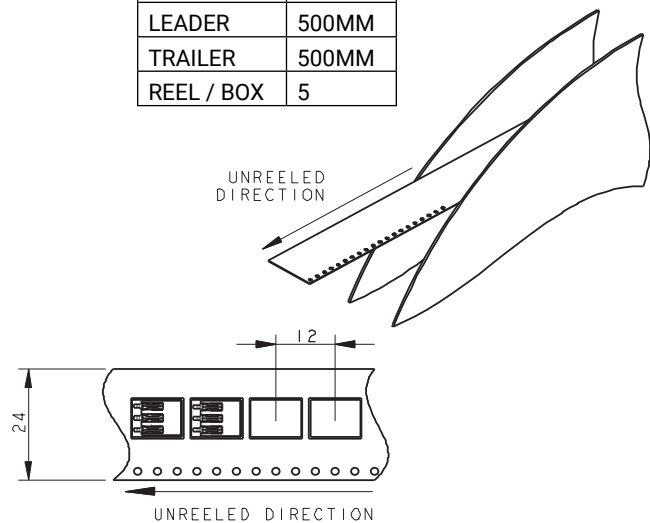

# BATTERY CONNECTORS

## Standard 2.5mm Pitch 9155-000



### 4 WAY BATTERY CONNECTOR REDUCED NOSE

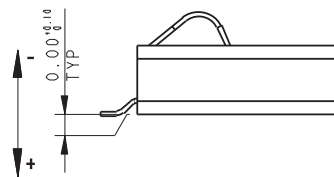
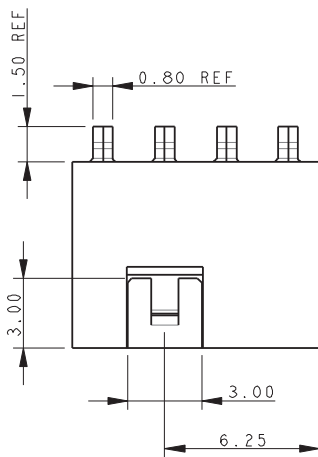
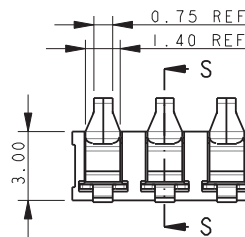
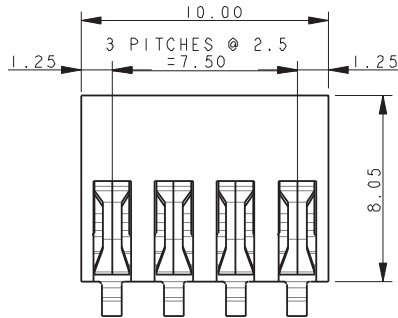

CONTACT TAILS TO BE WITHIN A 0.1 COPLANARITY RANGE WHEN INSULATOR IS SITTING ON DATUM FACE.

#### NOTES:

1. FOR MORE INFORMATION REFER TO PRODUCT SPEC 201-01-050.
2. GENERAL TOLERANCE  $\pm 0.20$  UNLESS OTHERWISE STATED.
3. FOR MATING PAD DETAILS REFER TO PAGE 9.
4. INSULATOR MATERIAL: 30% GLASS FILLED NYLON 46, UL94 V-O. COLOR BLACK.
5. CONTACT MATERIAL: BERYLLIUM COPPER.
6. CONTACT PLATING: SELECTIVE GOLD OVER NICKEL. PURE TIN ON TAILS.
7. BRACKET MATERIAL: PHOSPHOR BRONZE.
8. BRACKET PLATING: PURE TIN OVER NICKEL.

#### MATING CONDITIONS

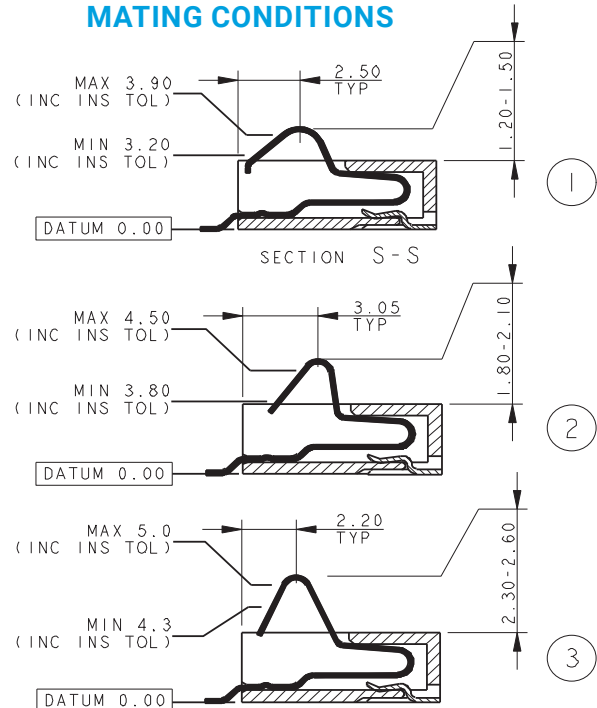

#### PCB BOARD LAYOUT

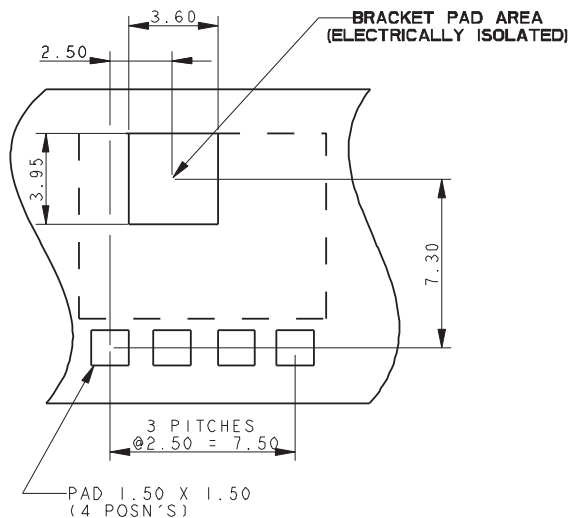

#### PACKING DETAILS

REEL QTY	1000
LEADER	500MM
TRAILER	500MM
REEL / BOX	5

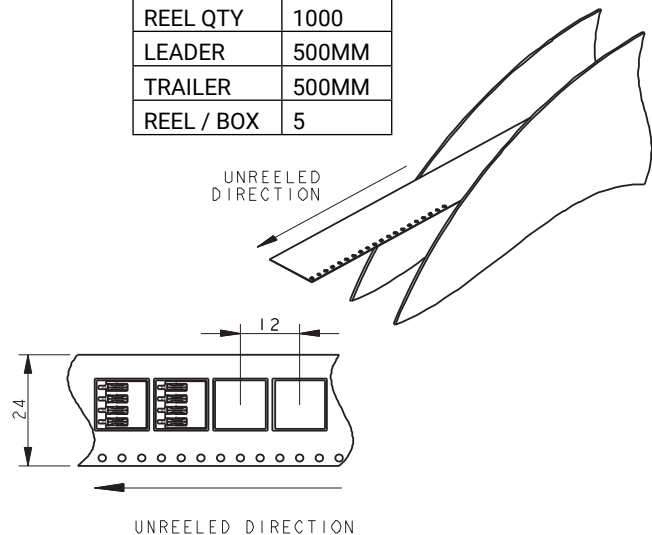

# BATTERY CONNECTORS

## Standard 2.5mm Pitch 9155-000

### 5 WAY BATTERY CONNECTOR REDUCED NOSE

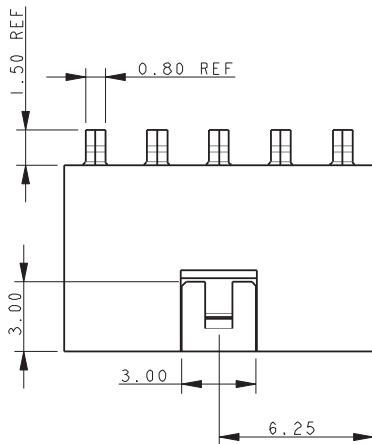
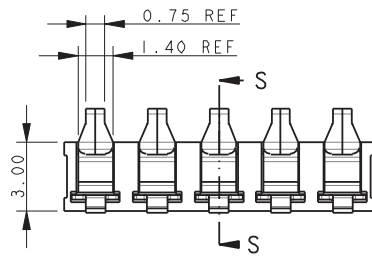
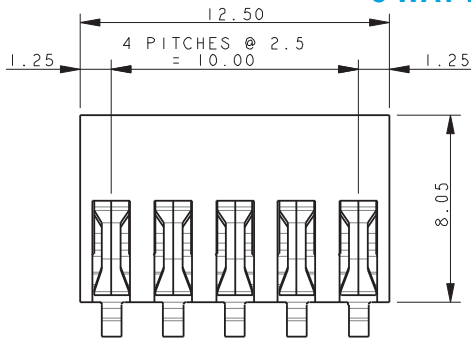

#### NOTES:

1. FOR MORE INFORMATION REFER TO PRODUCT SPEC 201-01-050.
2. GENERAL TOLERANCE  $\pm 0.20$  UNLESS OTHERWISE STATED.
3. FOR MATING PAD DETAILS REFER TO PAGE 9.
4. INSULATOR MATERIAL: 30% GLASS FILLED NYLON 46, UL94 V-0. COLOR BLACK.
5. CONTACT MATERIAL: BERYLLIUM COPPER.
6. CONTACT PLATING: SELECTIVE GOLD OVER NICKEL. PURE TIN ON TAILS.
7. BRACKET MATERIAL: PHOSPHOR BRONZE.
8. BRACKET PLATING: PURE TIN OVER NICKEL.

### MATING CONDITIONS

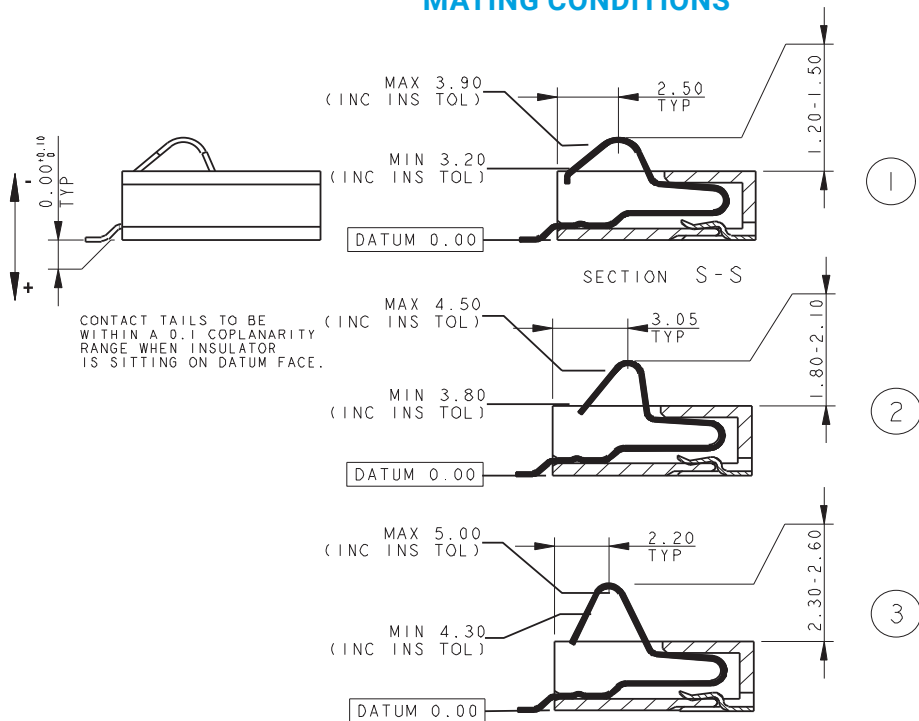

### PCB BOARD LAYOUT

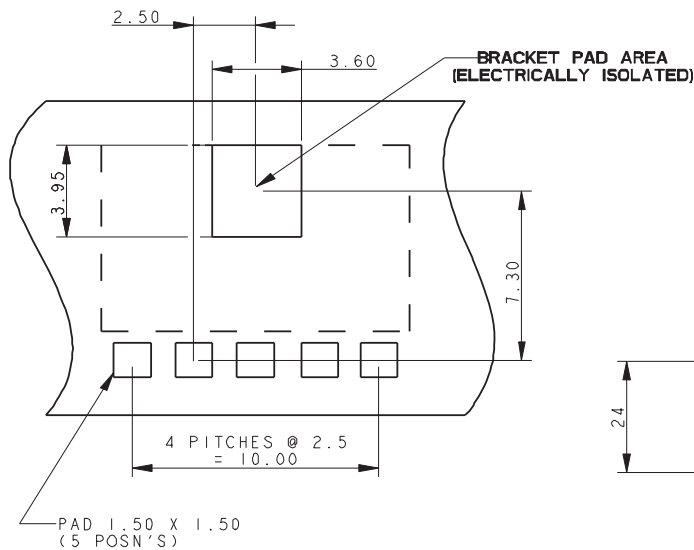

### PACKING DETAILS

REEL QTY	1000
LEADER	500MM
TRAILER	500MM
REEL / BOX	5

UNREELED DIRECTION

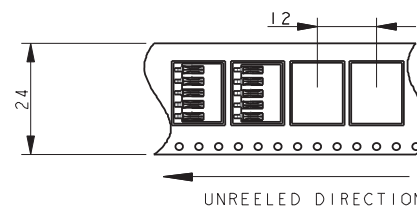
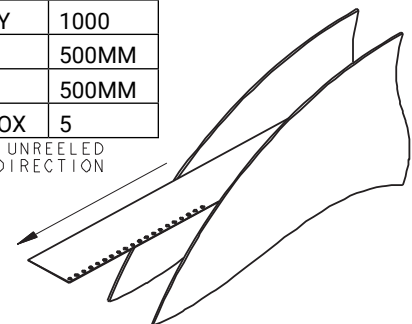

# BATTERY CONNECTORS

Standard 2.5mm Pitch 9155-000

## STANDARD BATTERY – MATING PADS

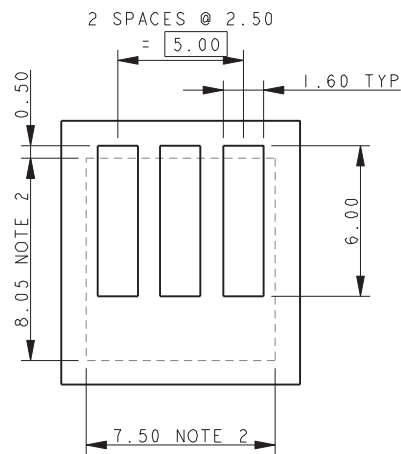

3 WAY MATING PADS

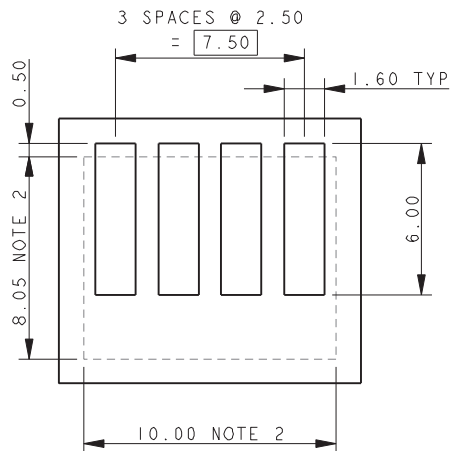

4 WAY MATING PADS

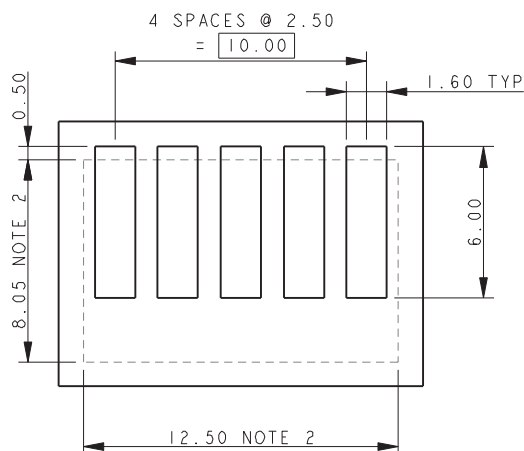

5 WAY MATING PADS

### NOTES:

1. SUGGESTED MATING PADS FOR STANDARD BATTERY CONNECTORS.
2. OUTLINE OF CONNECTOR.
3. PREFERRED PLATING ON PADS GOLD OVER NICKEL.
4. PAD LENGTH MAY REQUIRE ADJUSTMENT OF MATCH THE CUSTOMERS ASSEMBLY.
5. REFERENCE DIMENSIONS.

# Battery Connector 1.27mm Pitch

## 9155-020

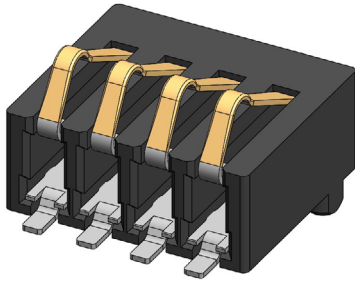

### GENERAL DESCRIPTION

Board-to-Board battery connectors were originally designed for mobile equipment, but now it can be used for much wider range of applications. KYOCERA AVX Interconnect extends their range of board-to-board battery connectors to include a 1.27mm small pitch part. This new version 9155-020 has a nominal working height 2.5-3.1mm. This series includes 2 through 5 position connectors that are end to end stackable. These connectors are rated at a full 3 Amps per contact for 2 & 3 ways and 2 Amps per contact for 4 & 5 ways.

The complete family of connectors 9155 series from Kyocera AVX offer all the same advantages: Ultra reliable and robust gold plated beryllium copper contacts provide high integrity connections in harsh environments, with up to 15000 mating operations. Parts are supplied in tape and reel for automatic pick and place. Whatever your requirements, the 9155 series battery connector can also be customized to suit our applications.

### APPLICATIONS

- Handheld/portable devices requiring docking or cradle charging
- Battery packs of portable oxygen generator products
- Patient monitoring or portable medical electronics
- Industrial devices requiring pluggable or programming modules
- Internet appliances requiring battery back-up

### SIZES

- 2pos thru 5pos

### ELECTRICAL

- Voltage Rating: 400 VAC
- Current Rating: 3 Amp / Contact (2 & 3 way)  
2 Amp / Contact (4 & 5 way)

### ENVIRONMENTAL

- Operating Temperature: -40°C to +125°C

### HOW TO ORDER

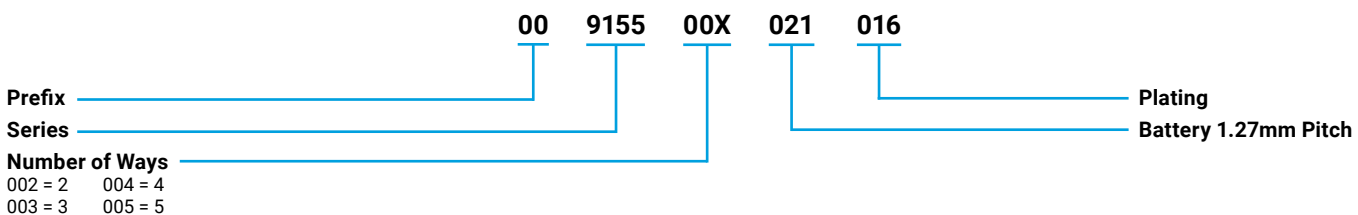

### FEATURES AND BENEFITS

- Insulator height 2.35mm
- Gold plated BeCu contacts provide high electrical and mechanical performance
- Small pitch 1.27mm is extending the range of using battery connectors 9155 series
- Flame retardant plastic per UL94 V-0
- End-to-end stackable

### MECHANICAL

- Insulator Material: Glass filled LCP plastic, flame retardant per UL94 V-0
- Contact Material: Beryllium Copper
- Plating: Gold on Nose, Pure Tin SMT terminations over base Nickel
- Durability: Up to 15000 Cycles



# Battery Connector 1.27mm Pitch

## 9155-020

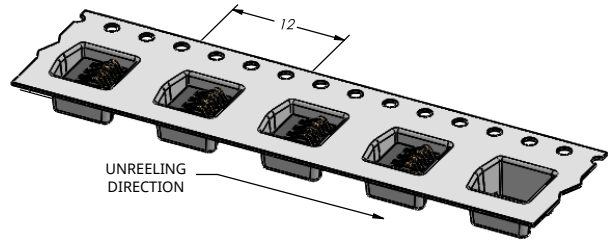
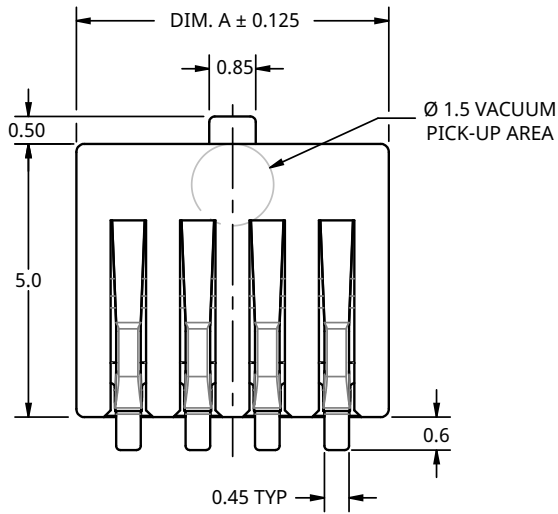

PACKAGING PER EIA-481  
1,100 PARTS PER 330 mm REEL

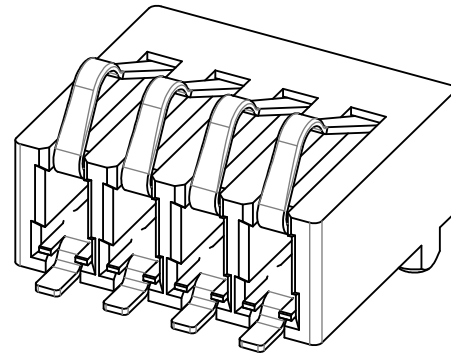
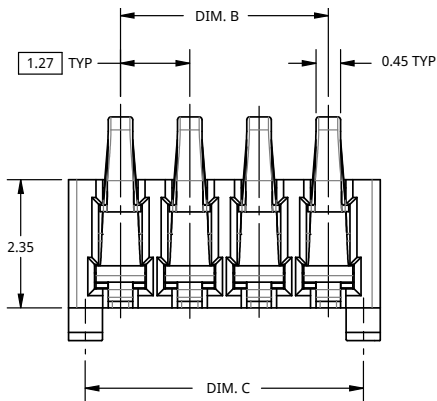

Part Number	POS.	DIM. A	DIM. B	DIM. C
00-9155-002-021-016	2	3.175	1.27	2.56
00-9155-003-021-016	3	4.445	2.54	3.83
00-9155-004-021-016	4	5.715	3.81	5.10
00-9155-005-021-016	5	6.985	5.08	6.37

# Battery Connector 1.27mm Pitch

## 9155-020

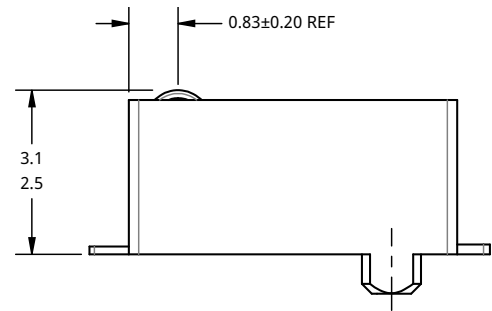
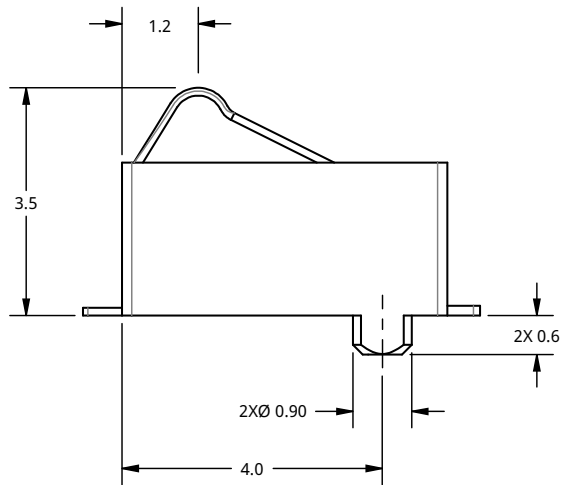

WORKING RANGE  
SEE NOTE 5

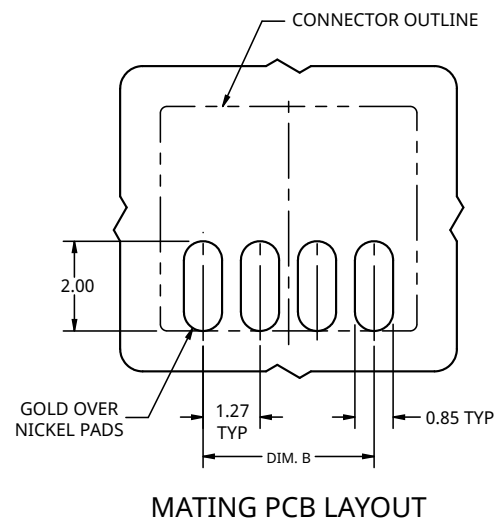
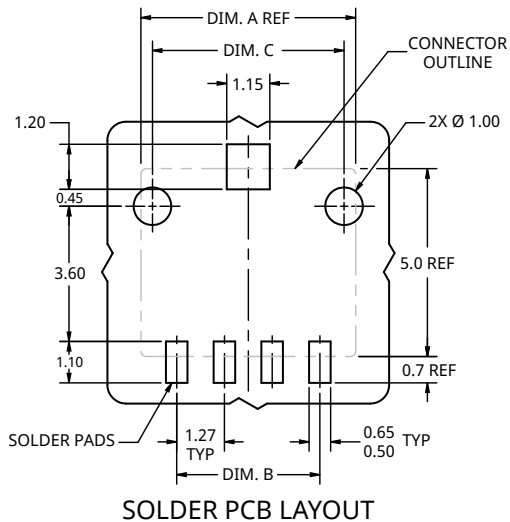

### NOTES:

- HOUSING MATERIAL: GLASS-FILLED THERMOPLASTIC FLAME RETARDANT PER UL94V-0; COLOR: BLACK
- CONTACT MATERIAL: BERYLLIUM COPPER
- PLATING: 0.8 µm MIN DUCTILE NICKEL UNDERPLATE ALL OVER; 0.75 µm MIN HARD GOLD IN CONTACT AREA; 1.5 - 3.0 µm LEAD-FREE MATTE TIN ON TAILS
- SOLDER TAB: TIN-PLATED COPPER ALLOY
- NORMAL FORCE WORKING RANGE: 0.30 TO 0.55 N

# BATTERY CONNECTORS

## Ultra-Low Profile 2.5mm Pitch 9155-100



KYOCERA AVX has been leading the industry with reliable Board-to-Board (BTB) compression connectors for commercial, medical and harsh industrial applications, obtaining the very first contact patent in the early 1990's. The broad range of connectors offers both signal contacts which support 1 Amp/contact up to 40 position as well as low pin count (LPC) power contacts up to 3 Amps/contact.

The newest addition is the Ultra Low Profile (ULP) power connector that supports a 1.3mm compressed height, the lowest on the market. Gold plated Beryllium Copper (BeCu) contacts offers the most reliable and resilient contact performance in this miniature package. The sweeping contact design offers 0.7mm deflection range, long contact wipe and in excess of 40 grams of contact force at minimum operating deflection. All combined, this connector is rated at an unbelievable 5000 mating cycles for mechanical endurance.

### APPLICATIONS

- Low profile power, signal, ground or shielding requirements
- Repeatable/Pluggable module or battery pack requirements
- Low profile flex circuit to PCB applications
- Portable devices

### FEATURES AND BENEFITS

- High Reliability / High Cycle Life BeCu contacts for maximum system performance
- ULP 1.3mm minimum operating height with 0.7mm "Z" axis compression/ tolerance range
- Gold plating supports a broad range applications based on reliability and environments
- 3 Amp contact rating over a -40°C to +105°C operating range supports a broad application spectrum

### ELECTRICAL

- Current Rating: 3 Amps/Contact
- Voltage Rating: 125VAC

### ENVIRONMENTAL

- Operating Temperature: -40°C to +105°C

### MECHANICAL

- Insulator Material: Glass-Filled Nylon 46; UL94 V-0
- Contact Material: Beryllium Copper
- Plating: Gold over Nickel
- Durability: 5000 Cycles

### HOW TO ORDER

**00** Prefix  
**9155** Series  
**00X** No. of Ways  
 2 = 002  
 3 = 003

**10X** Low Profile Battery Connector

Code	Description	Operating Height
100	Low Profile Battery Connector No Stop	1.30 (0.051)
101	Low Profile Battery Connector Stop	1.30 (0.051)

**00X** Plating Option

Code	Description
006	0.4μm Selective Gold, Standard
008	0.8μm Selective Gold, Special Order



# BATTERY CONNECTORS

## Ultra-Low Profile 2.5mm Pitch 9155-100



### 2 WAY LOW PROFILE CONNECTOR NO STOP

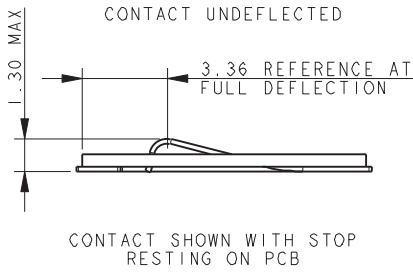
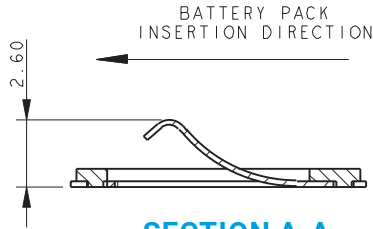

CONTACT SHOWN WITH STOP RESTING ON PCB

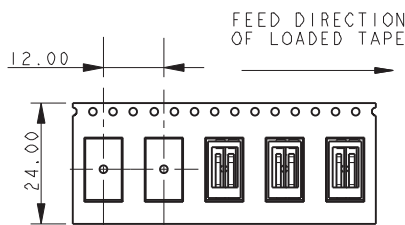
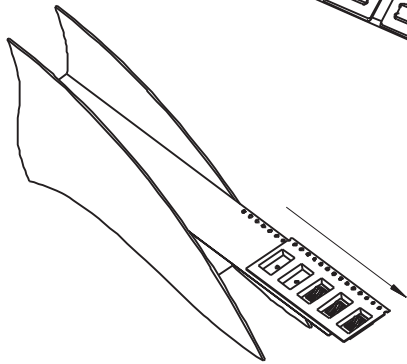
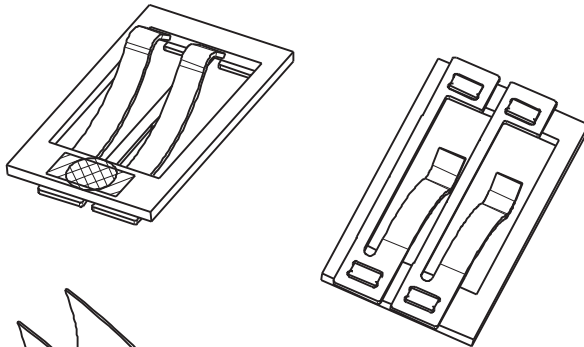

### PACKING DETAILS

REEL QTY	1500
LEADER	500MM
TRAILER	KYOCERA AVX

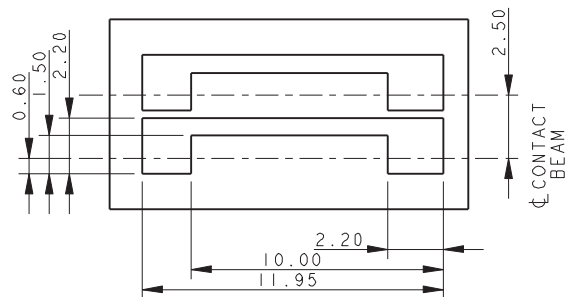
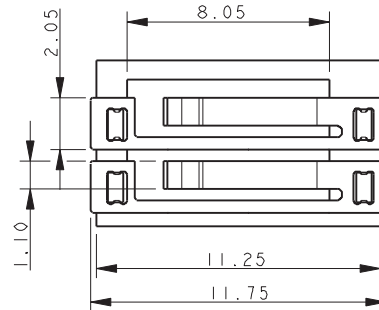
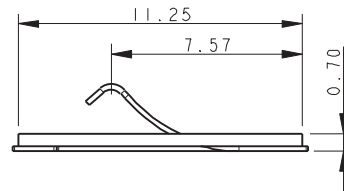
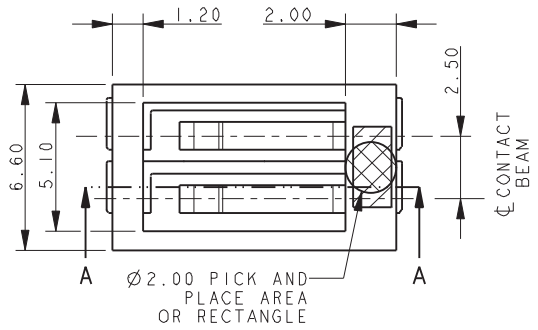

### SUGGESTED PCB LAYOUT

#### NOTES:

1. FOR FULL PRODUCT SPECIFICATION REFER TO ELCO SPECIFICATION 201-01-094.
2. MATERIALS: CONTACT - COPPER ALLOY, INSULATOR - GLASS FILLED NYLON. COLOR: BLACK.
3. TOLERANCE  $\pm 0.20$  UNLESS SPECIFIED.
4. PACKING DETAILS SEE TABLE.
5. FOR MATING PAD DETAILS REFER TO PAGE 16.

The Important Information/Disclaimer is incorporated in the catalog where these specifications came from or available online at [www.kyocera-avx.com/disclaimer/](http://www.kyocera-avx.com/disclaimer/) by reference and should be reviewed in full before placing any order.

# BATTERY CONNECTORS

## Ultra-Low Profile 2.5mm Pitch 9155-100



### 3 WAY LOW PROFILE CONNECTOR NO STOP

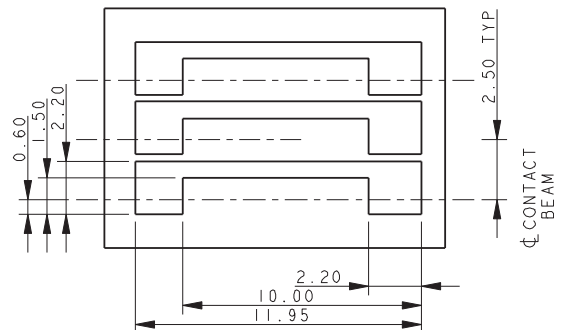
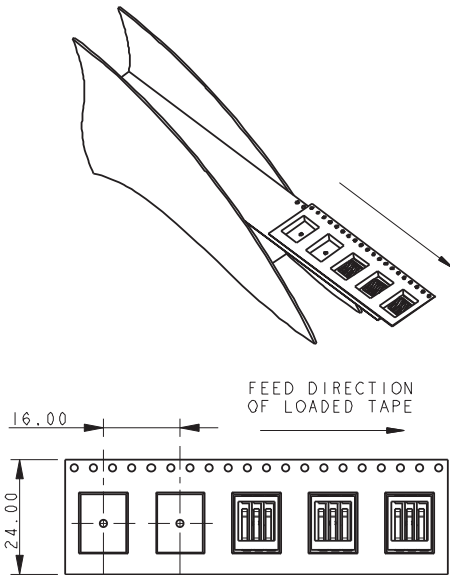
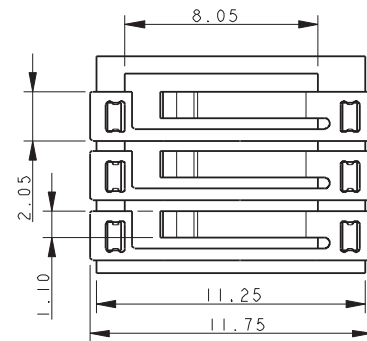
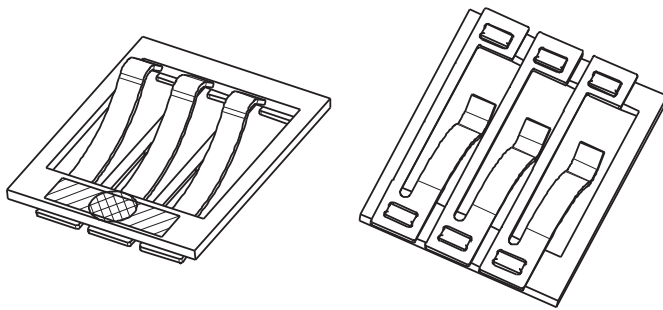
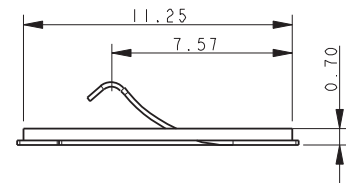
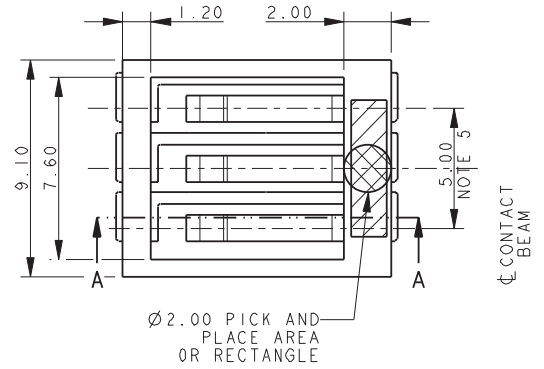
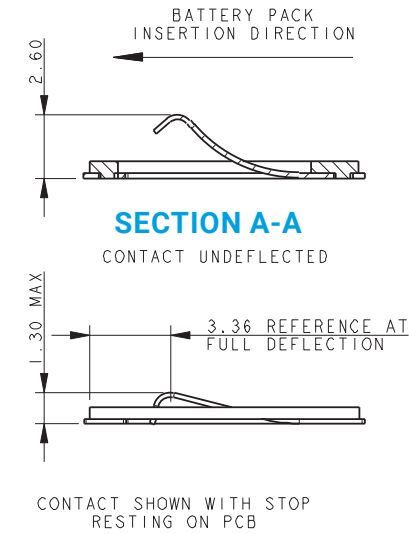

### SUGGESTED PCB LAYOUT

#### NOTES:

1. FOR FULL PRODUCT SPECIFICATION REFER TO ELCO SPECIFICATION 201-01-094.
2. MATERIALS: CONTACT - COPPER ALLOY, INSULATOR - GLASS FILLED NYLON. COLOR: BLACK.
3. TOLERANCE  $\pm 0.20$  UNLESS SPECIFIED.
4. PACKING DETAILS SEE TABLE.
5. 2 EQUAL PITCHES @ 2.50 = 5.00.
6. FOR MATING PAD DETAILS REFER TO PAGE 16.

### PACKING DETAILS

REEL QTY	1200
LEADER	500MM
TRAILER	500MM



The Important Information/Disclaimer is incorporated in the catalog where these specifications came from or available online at [www.kyocera-avx.com/disclaimer/](http://www.kyocera-avx.com/disclaimer/) by reference and should be reviewed in full before placing any order.

092921

# BATTERY CONNECTORS

## Ultra-Low Profile 2.5mm Pitch 9155-100

### 2 WAY LOW PROFILE CONNECTOR WITH STOP

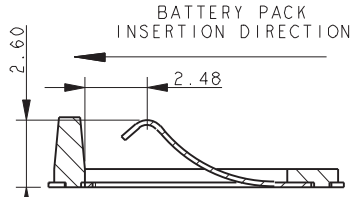

**SECTION A-A**

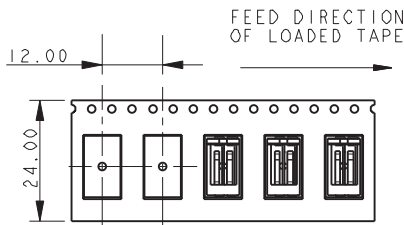
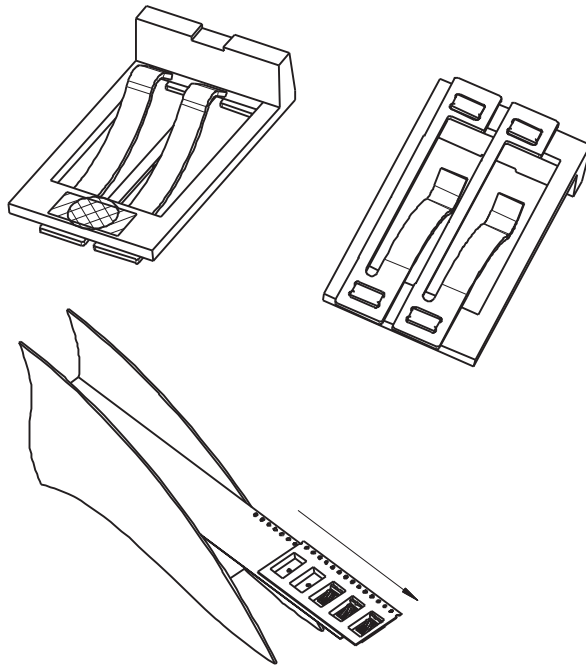
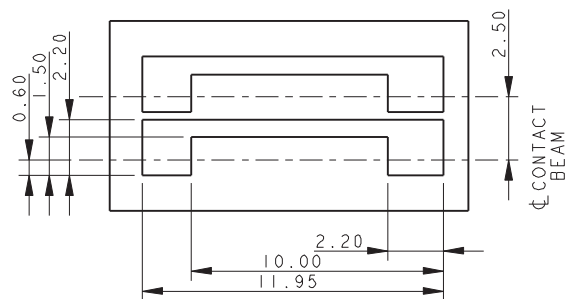
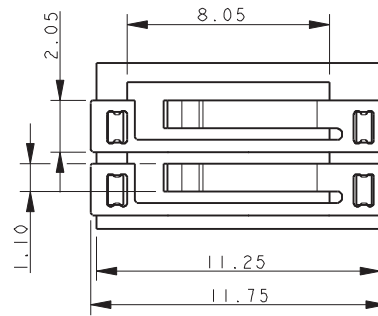
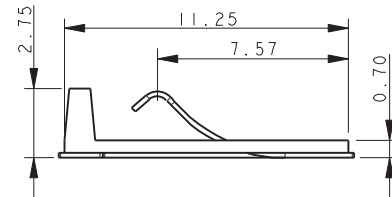
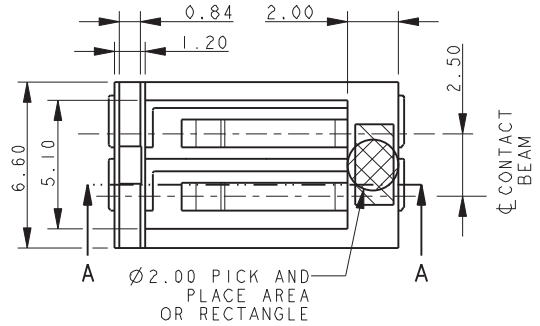
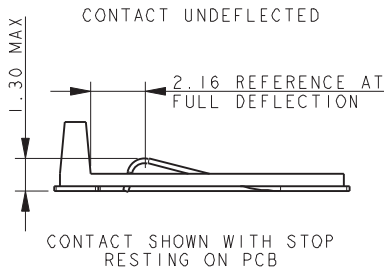

**PACKING DETAILS**

REEL QTY	1500
LEADER	500MM
TRAILER	500MM

### SUGGESTED PCB LAYOUT

**NOTES:**

1. FOR FULL PRODUCT SPECIFICATION REFER TO ELCO SPECIFICATION 201-01-094.
2. MATERIALS: CONTACT - COPPER ALLOY, INSULATOR - GLASS FILLED NYLON. COLOR: BLACK.
3. TOLERANCE ±0.20 UNLESS SPECIFIED.
4. PACKING DETAILS SEE TABLE.
5. FOR MATING PAD DETAILS REFER TO PAGE 16.

# BATTERY CONNECTORS

## Ultra-Low Profile 2.5mm Pitch 9155-100



### 3 WAY LOW PROFILE CONNECTOR WITH STOP

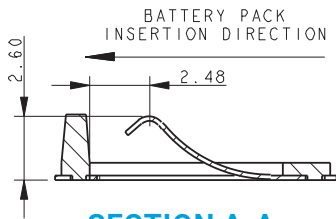

**SECTION A-A**  
CONTACT UNDEFLECTED

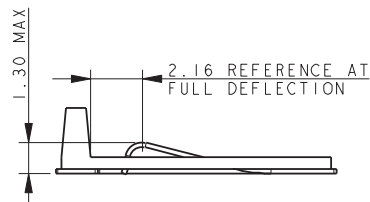

CONTACT SHOWN WITH STOP RESTING ON PCB

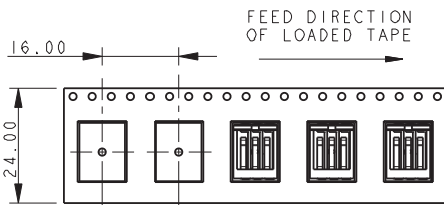
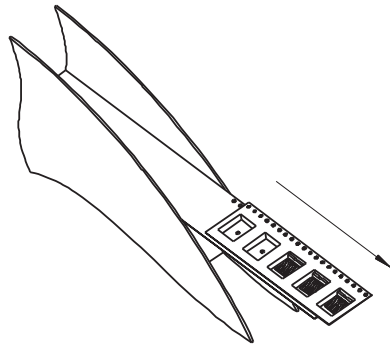
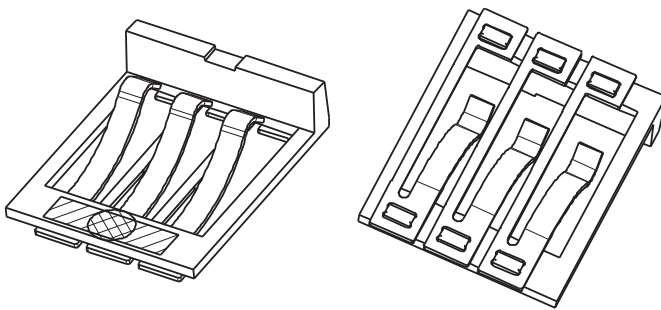

### PACKING DETAILS

Reel Qty	1200
Leader	500MM
Trailer	500MM

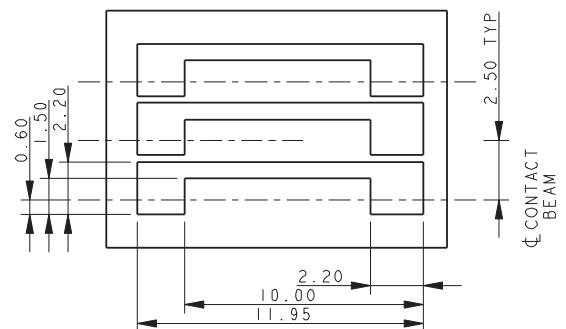
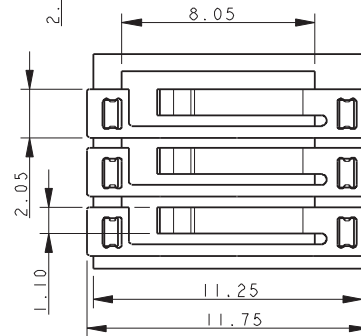
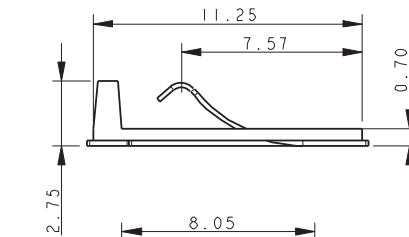
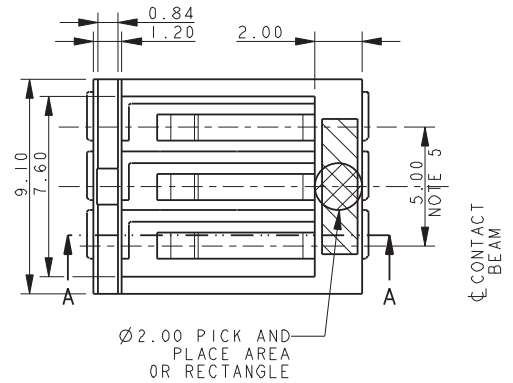

### SUGGESTED PCB LAYOUT

#### NOTES:

1. FOR FULL PRODUCT SPECIFICATION REFER TO ELCO SPECIFICATION 201-01-094.
2. MATERIALS: CONTACT - COPPER ALLOY, INSULATOR - GLASS FILLED NYLON. COLOR: BLACK.
3. TOLERANCE  $\pm 0.20$  UNLESS SPECIFIED.
4. PACKING DETAILS SEE TABLE.
5. 2 EQUAL PITCHES @ 2.50 = 5.00.
6. FOR MATING PAD DETAILS REFER TO PAGE 16.

# BATTERY CONNECTORS

## Ultra-Low Profile 2.5mm Pitch 9155-100

### LOW PROFILE MATING PADS

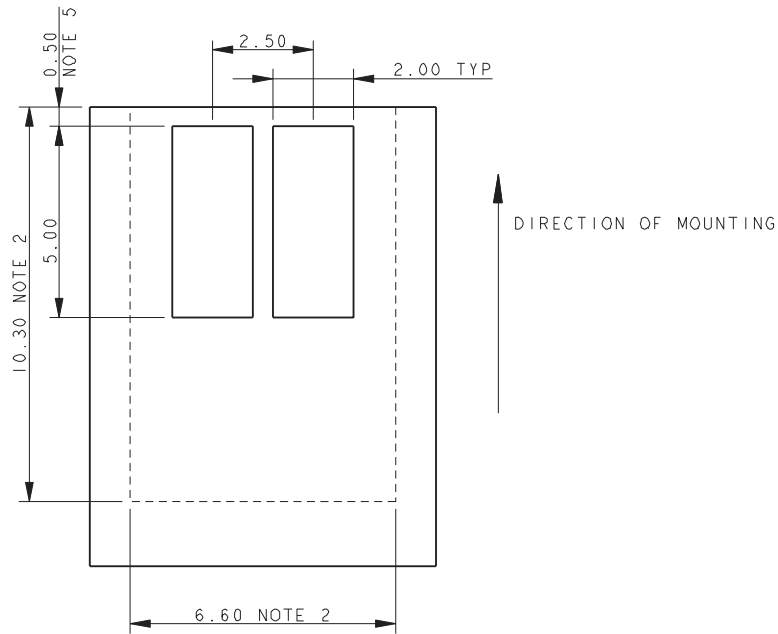

### 2 WAY MATING PADS

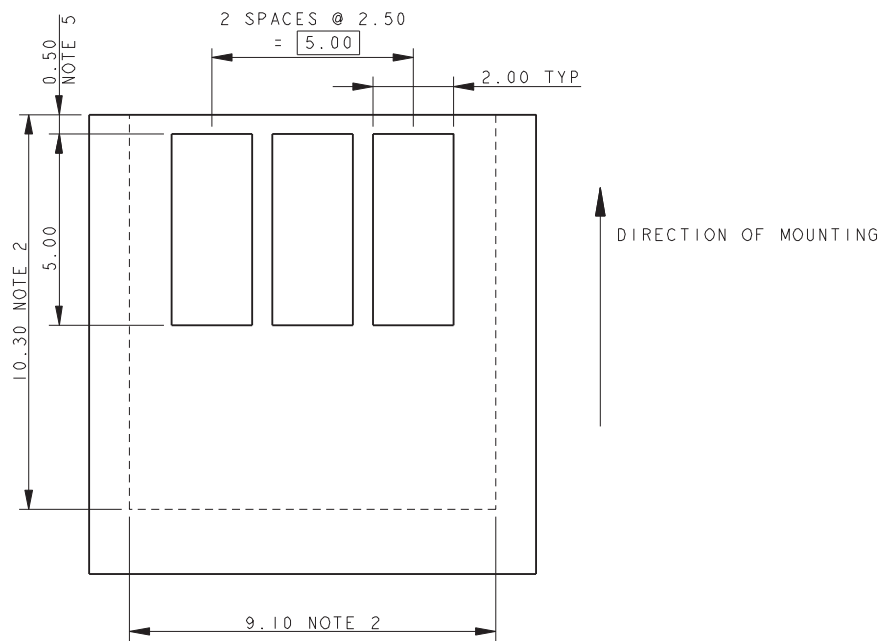

### 3 WAY MATING PADS

#### NOTES:

1. SUGGESTED MATING PADS FOR LOW PROFILE BATTERY CONNECTORS.
2. OUTLIE OF CONNECTOR.
3. PROFERED PLATING ON PADS GOLD OVER NICKEL.
4. REFERENCE DIMENSIONS.
5. DIMENSION TO EDGE OF BOARD FOR CONNECTORS WITH STOP.



# BATTERY CONNECTORS

## Reduced 2.5mm Pitch 9155-200

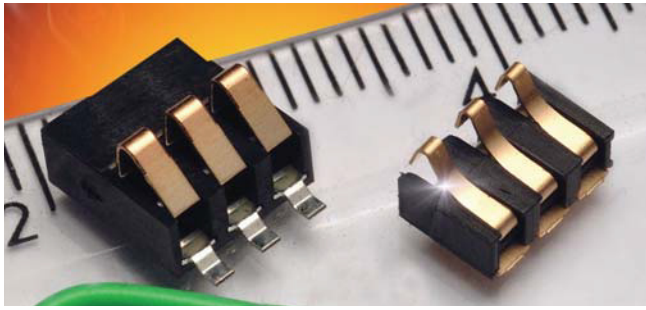

The newest product in KYOCERA AVX Interconnect family of battery connectors saves 50% in volume over the initial 9155 series compression connectors as illustrated in the photograph. These connectors are rated at a full 3 amps per contact on 2.5mm centers. Sizes range from 2 positions through 5 positions and are end to end stackable.

### APPLICATIONS

- Cellular Phones
- Handheld Devices
- Industrial Modules
- Medical Electronics

### FEATURES AND BENEFITS

- 2.4mm insulator height
- 3 amps/contact
- Large SMT mounting area for positive mechanical attachment
- 5k mating cycles
- End-to-end stackable

### ELECTRICAL

- Current Rating: 3 Amp / Contact
- Voltage Rating: 125 VAC

### ENVIRONMENTAL

- Operating Temperature: -40°C to +125°C

### MECHANICAL

- Insulator Material: Glass-Filled Nylon 46; UL94 HB
- Contact Material: Beryllium Copper
- Plating: Gold over Nickel
- Durability: 5000 Cycles

### HOW TO ORDER

<b>00</b>	<b>9155</b>	<b>00X</b>
Prefix	Series	No. of Ways
		2 = 002
		3 = 003
		4 = 004
		5 = 005

<b>201</b>				
Reduced Size Battery Connector				
<table border="1" style="width: 100%; border-collapse: collapse;"> <thead> <tr> <th style="width: 20%;">Code</th> <th>Description</th> </tr> </thead> <tbody> <tr> <td style="text-align: center;">201</td> <td>Reduced Size Battery Connector</td> </tr> </tbody> </table>	Code	Description	201	Reduced Size Battery Connector
Code	Description			
201	Reduced Size Battery Connector			

<b>00X</b>						
Plating Option						
<table border="1" style="width: 100%; border-collapse: collapse;"> <thead> <tr> <th style="width: 20%;">Code</th> <th>Description</th> </tr> </thead> <tbody> <tr> <td style="text-align: center;">006</td> <td>0.4µm Selective Gold, Standard</td> </tr> <tr> <td style="text-align: center;">008</td> <td>0.8µm Selective Gold, Special Order</td> </tr> </tbody> </table>	Code	Description	006	0.4µm Selective Gold, Standard	008	0.8µm Selective Gold, Special Order
Code	Description					
006	0.4µm Selective Gold, Standard					
008	0.8µm Selective Gold, Special Order					



# BATTERY CONNECTORS

## Reduced 2.5mm Pitch 9155-200

### 2 WAY REDUCED SIZE BATTERY CONNECTOR

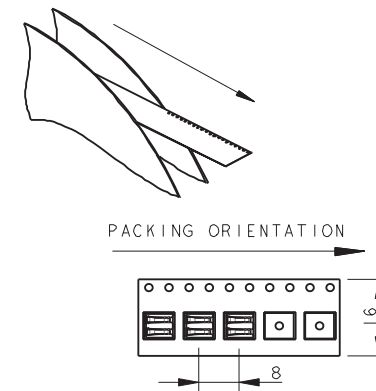
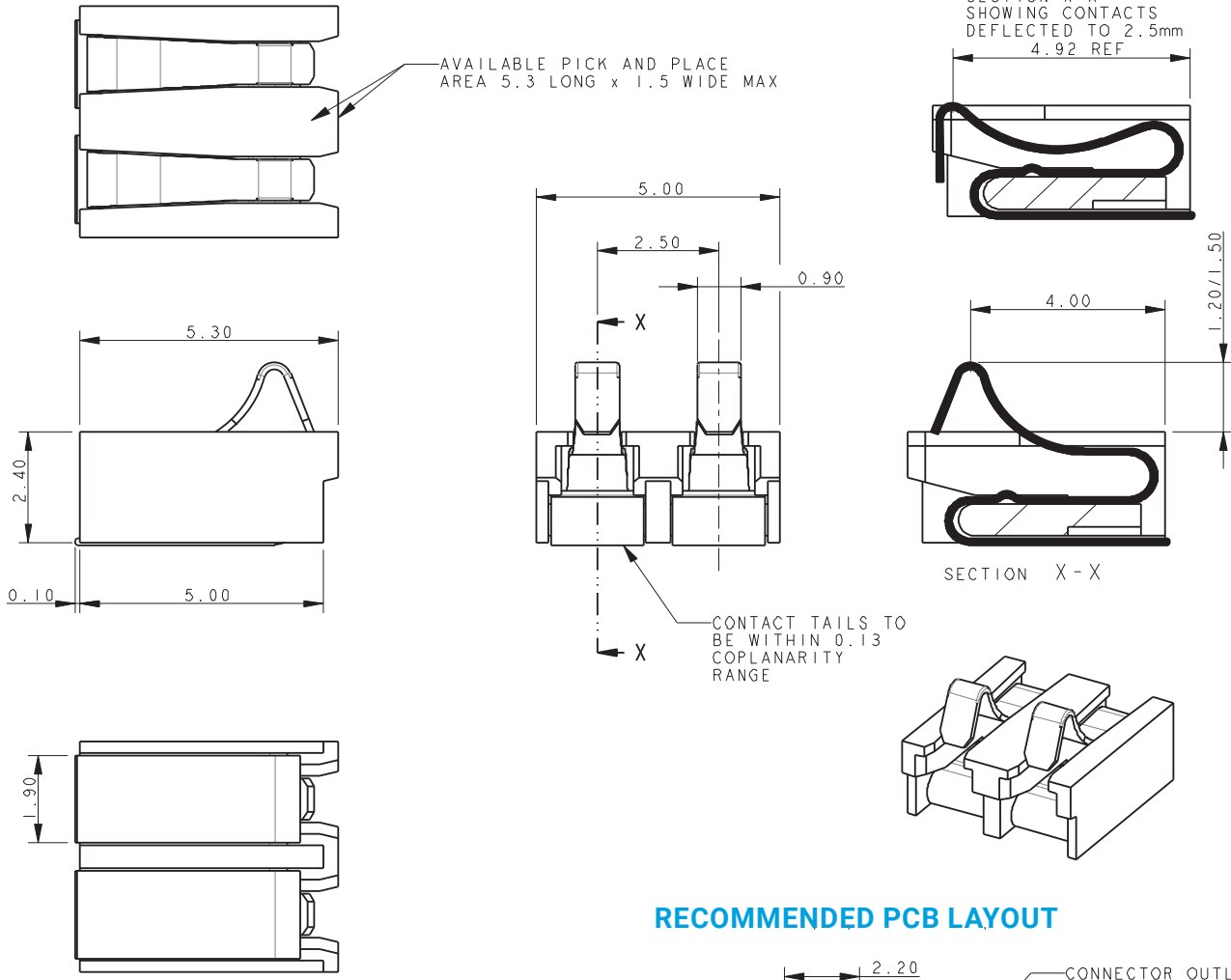

### PACKING DETAILS

Reel Qty	2000
Leader	500MM
Trailer	500MM

### RECOMMENDED PCB LAYOUT

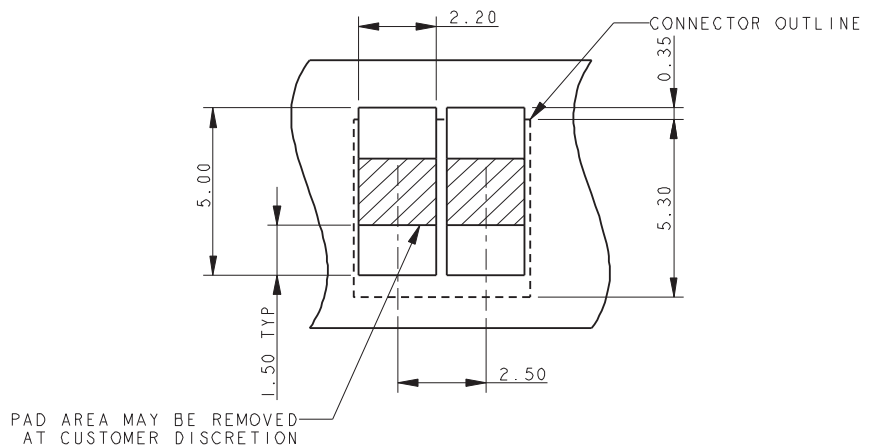

### NOTES:

1. FOR FULL PRODUCT SPECIFICATION REFER TO ELCO SPECIFICATION 201-01-093.
2. FOR MATING PAD DETAILS REFER TO PAGE 22.
3. GENERAL TOLERANCE  $\pm 0.20$ .
4. INSULATOR MATERIAL: 30% GLASS FILLED NYLON 46, UL94 HB, COLOR BLACK.
5. CONTACT MATERIAL: BERYLLIUM COPPER.
6. CONTACT PLATING: SELECTIVE GOLD OVER NICKEL. PURE TIN ON TAILS.

# BATTERY CONNECTORS

## Reduced 2.5mm Pitch 9155-200

### 3 WAY REDUCED SIZE BATTERY CONNECTOR

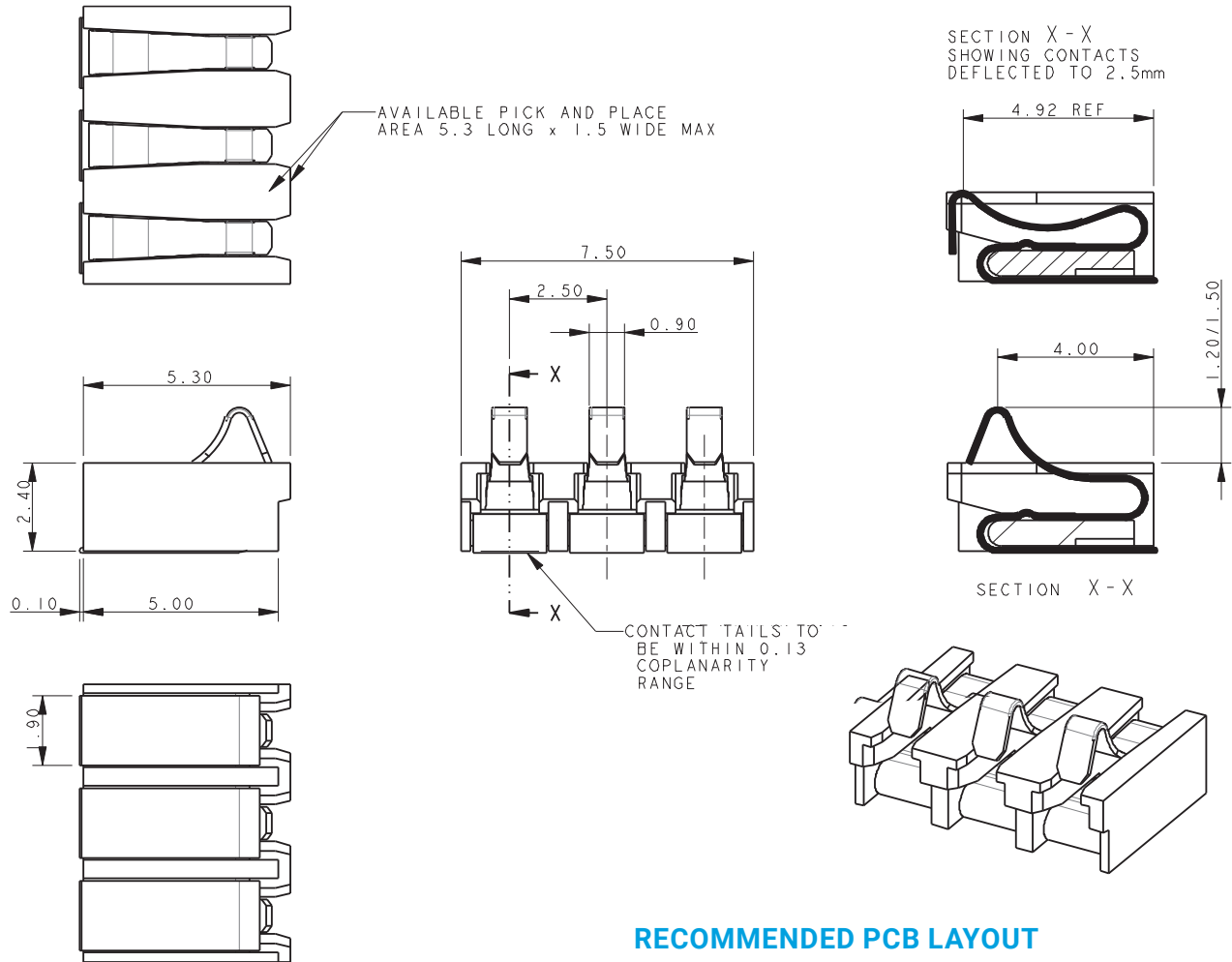

### RECOMMENDED PCB LAYOUT

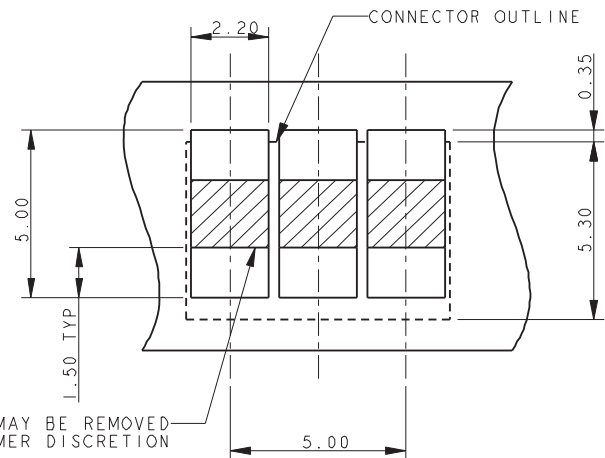
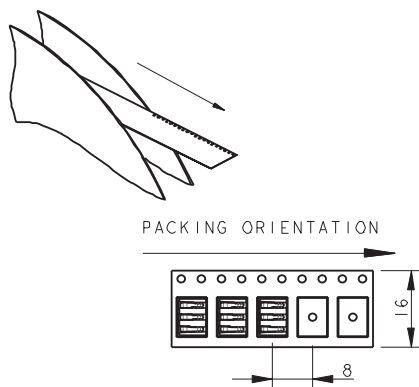

### PACKING DETAILS

REEL QTY	2000
LEADER	500MM
TRAILER	500MM

### NOTES:

1. FOR FULL PRODUCT SPECIFICATION REFER TO ELCO SPECIFICATION 201-01-093.
2. FOR MATING PAD DETAILS REFER TO PAGE 22.
3. GENERAL TOLERANCE  $\pm 0.20$ .
4. INSULATOR MATERIAL: 30% GLASS FILLED NYLON 46, UL94 HB, COLOR BLACK.
5. CONTACT MATERIAL: BERYLLIUM COPPER.
6. CONTACT PLATING: SELECTIVE GOLD OVER NICKEL. PURE TIN ON TAILS.

# BATTERY CONNECTORS

## Reduced 2.5mm Pitch 9155-200

### 4 WAY REDUCED SIZE BATTERY CONNECTOR

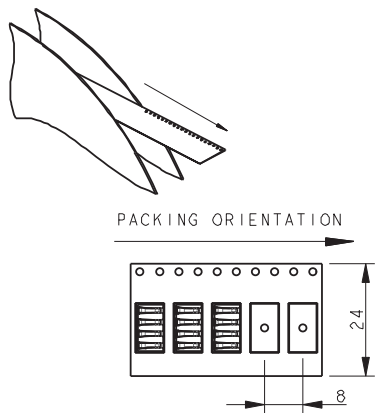
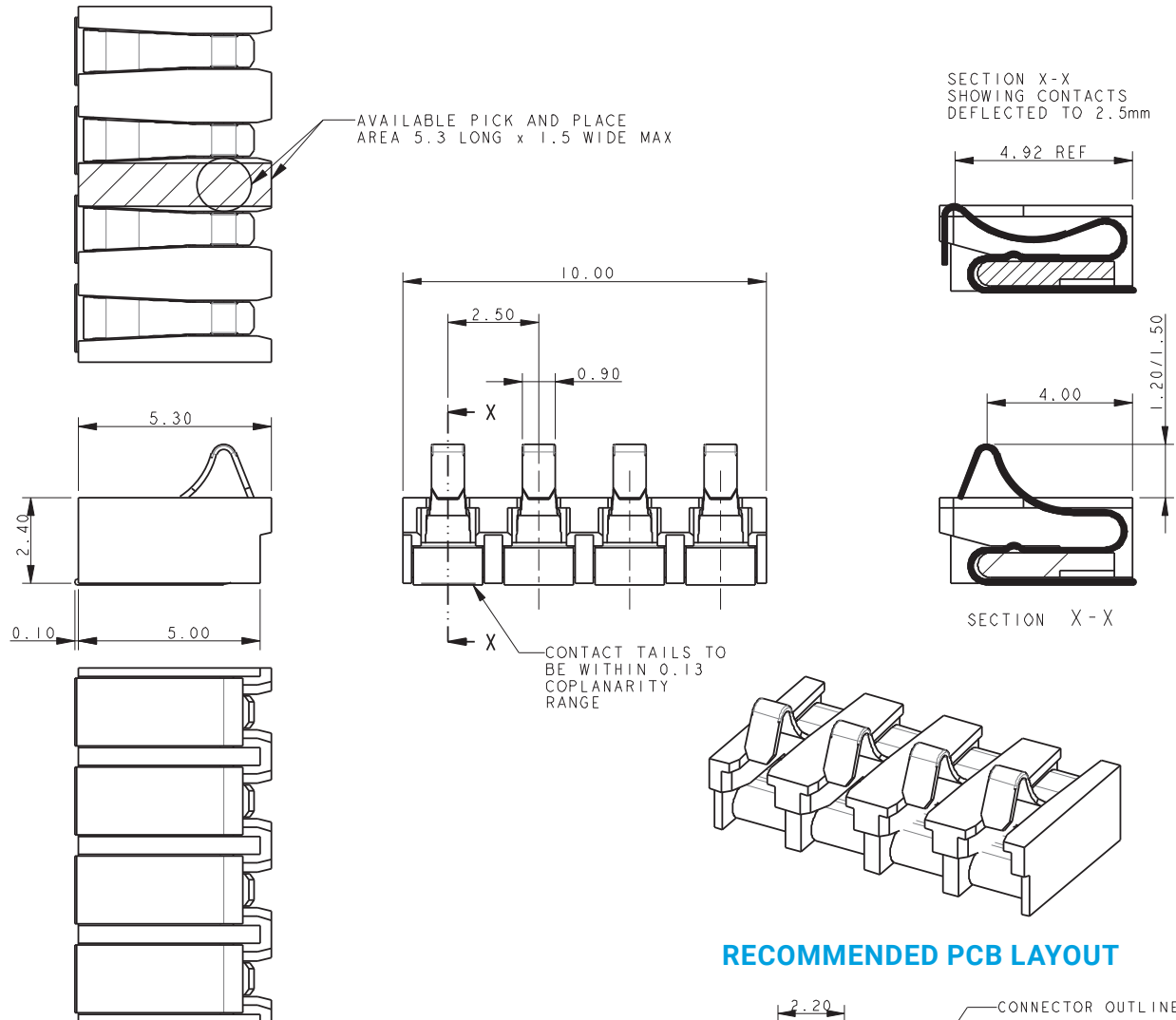

### PACKING DETAILS

REEL QTY	2000
LEADER	500MM
TRAILER	500MM

### RECOMMENDED PCB LAYOUT

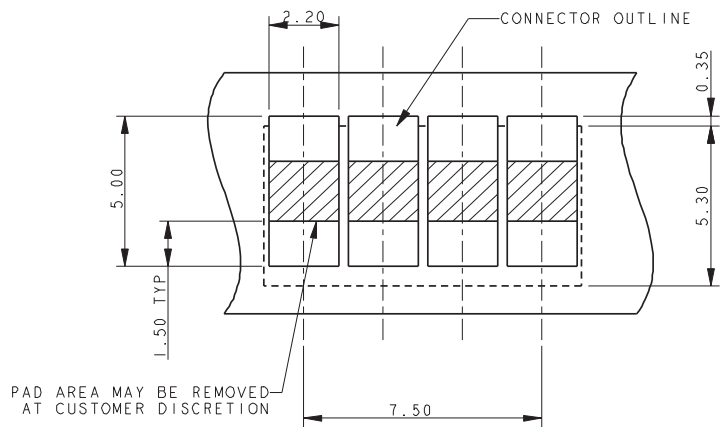

### NOTES:

1. FOR FULL PRODUCT SPECIFICATION REFER TO ELCO SPECIFICATION 201-01-093.
2. FOR MATING PAD DETAILS REFER TO PAGE 22.
3. GENERAL TOLERANCE  $\pm 0.20$ .
4. INSULATOR MATERIAL: 30% GLASS FILLED NYLON 46, UL94 HB, COLOR BLACK.
5. CONTACT MATERIAL: BERYLLIUM COPPER.
6. CONTACT PLATING: SELECTIVE GOLD OVER NICKEL. PURE TIN ON TAILS.

# BATTERY CONNECTORS

## Reduced 2.5mm Pitch 9155-200

### 5 WAY REDUCED SIZE BATTERY CONNECTOR

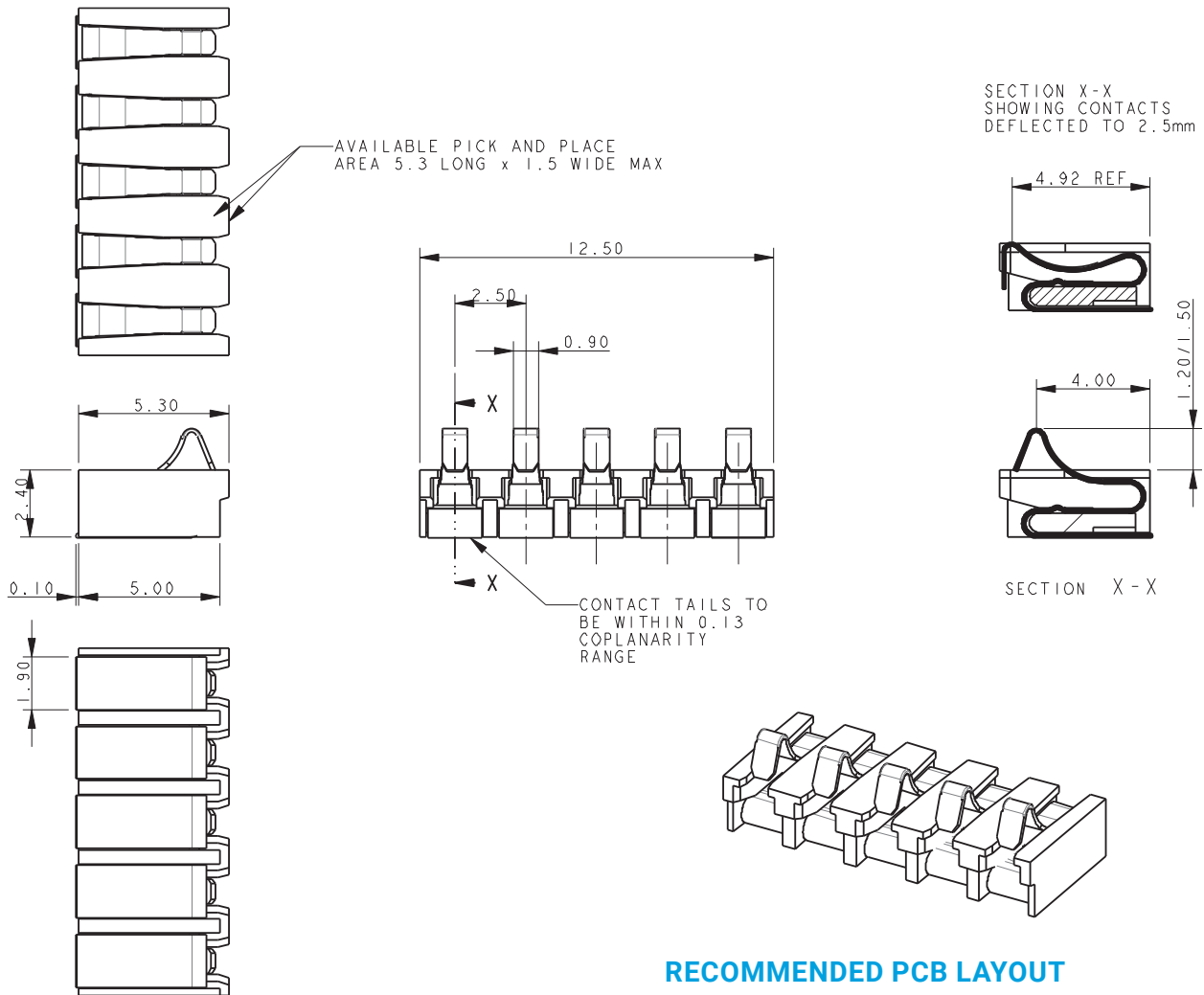

### RECOMMENDED PCB LAYOUT

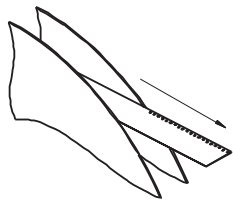
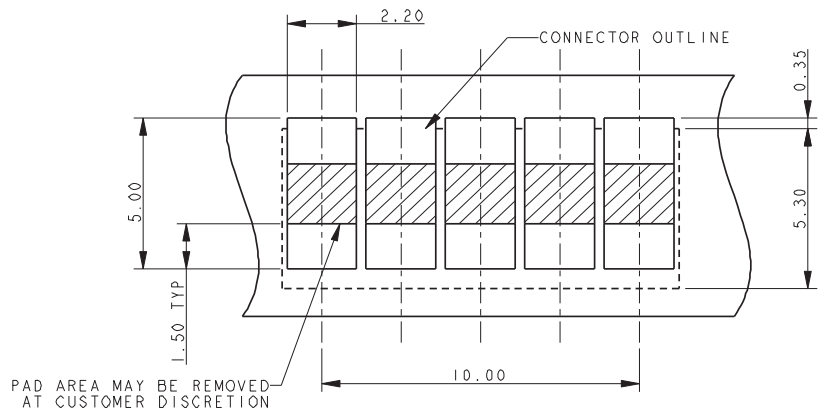

### PACKING ORIENTATION

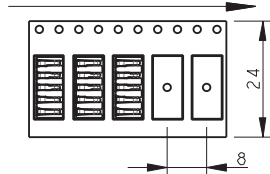

### PACKING DETAILS

REEL QTY	2000
LEADER	500MM
TRAILER	500MM

### NOTES:

1. FOR FULL PRODUCT SPECIFICATION REFER TO ELCO SPECIFICATION 201-01-093.
2. FOR MATING PAD DETAILS REFER TO PAGE 22.
3. GENERAL TOLERANCE  $\pm 0.20$ .
4. INSULATOR MATERIAL: 30% GLASS FILLED NYLON 46, UL94 HB, COLOR BLACK.
5. CONTACT MATERIAL: BERYLLIUM COPPER.
6. CONTACT PLATING: SELECTIVE GOLD OVER NICKEL. PURE TIN ON TAILS.

**REDUCED SIZE BATTERY CONNECTOR – MATING PADS**

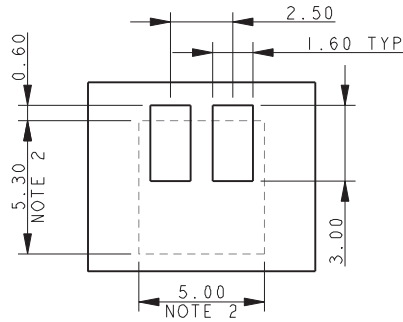

**2 WAY MATING PADS**

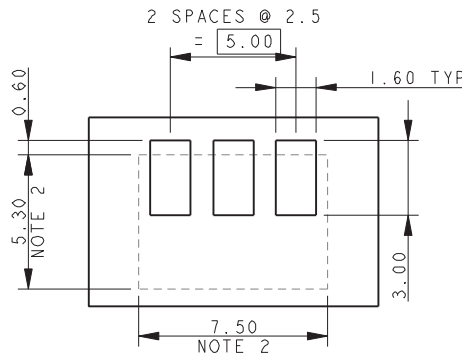

**3 WAY MATING PADS**

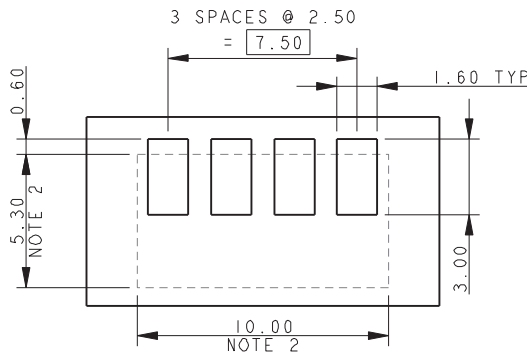

**4 WAY MATING PADS**

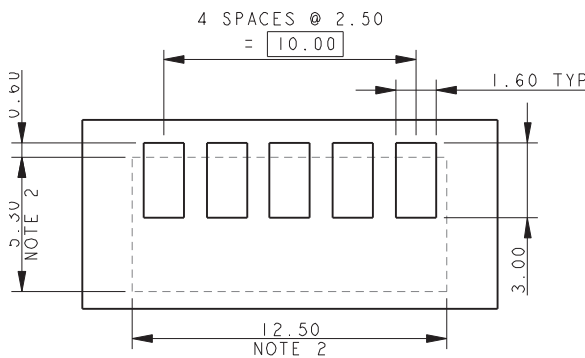

**5 WAY MATING PADS**

**NOTES:**

1. SUGGESTED MATING PADS FOR REDUCED SIZE BATTERY CONNECTORS.
2. OUTLINE OF CONNECTOR.
3. PREFERRED PLATING ON PADS GOLD OVER NICKEL.
4. REFERENCE DIMENSIONS.

# BATTERY CONNECTORS

## Reduced 2.5mm Pitch 9155-250

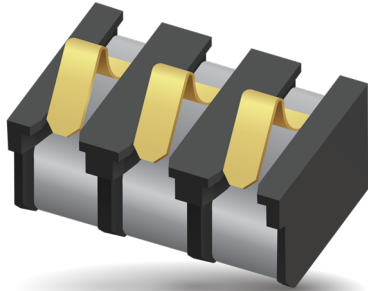

### GENERAL DESCRIPTION

KYOCERA AVX Interconnect extends their range of board-to-board reduced battery connectors. This new version 9155-250 has a nominal working height of 4.5mm compared with the existing 9155-200 which has a nominal working height of 3mm. These connectors are rated at a full 3 Amps per contact on 2.5mm centers. This series includes 2 through 5 position connectors that are end to end stackable.

The complete family of connectors 9155 series from KYOCERA AVX offer all the same advantages: Ultra reliable and robust gold plated beryllium copper contacts provide high integrity connections in harsh environments, with 5000 mating operations, high temperature nylon plastic for RoHS soldering. Additionally, 9155-250 is made from halogen free nylon.

### APPLICATIONS

- Handheld/portable devices requiring docking or cradle charging
- Patient monitoring or portable medical electronics
- Industrial devices requiring pluggable or programming modules
- Internet appliances requiring battery back-up

### FEATURES AND BENEFITS

- Insulator height 3.6mm
- Gold plated BeCu contacts provide high electrical and mechanical performance over 5000 mating cycles
- Halogen free high temperature nylon plastic, UL94V-0 rated
- End-to-end stackable

### ELECTRICAL

- Current Rating: 3 Amp/Contact
- Voltage Rating: 125 VAC

### ENVIRONMENTAL

- Operating Temperature: -40°C to +125°C

### MECHANICAL

- Insulator Material: High Temperature Halogen Free Plastic to UL94V-0 rated
- Contact Material: Beryllium Copper
- Plating: Gold on Nose, Pure Tin SMT terminations over base Nickel
- Durability: 5000 Cycles



### HOW TO ORDER

**00**

Prefix

**9155**

Series

**00X**

No. of Ways

- 2 = 002
- 3 = 003
- 4 = 004
- 5 = 005

**251**

Reduced Size  
Battery Connector

Code	Description
251	Reduced 2.5mm Size Battery Connector

**00X**

Plating Option

Code	Description
006	0.4µm Selective Gold, Standard

# BATTERY CONNECTORS

## Reduced 2.5mm Pitch 9155-250

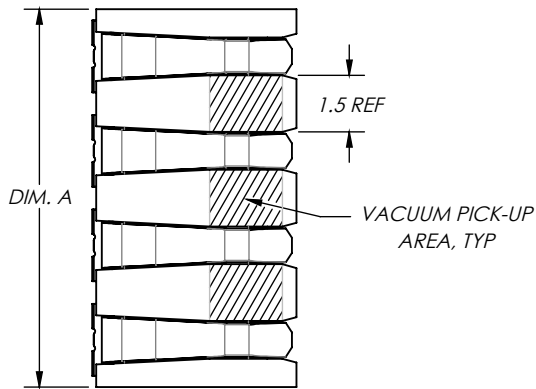

### 3 AND 5 POSITION PARTS

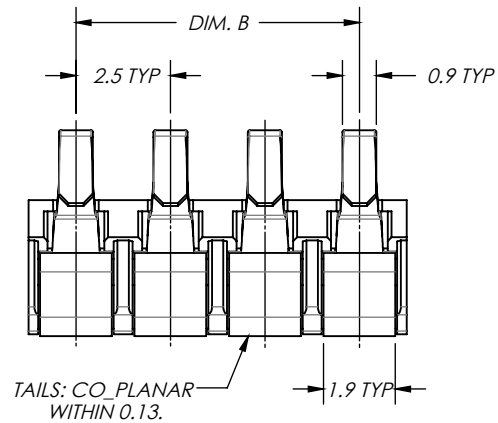
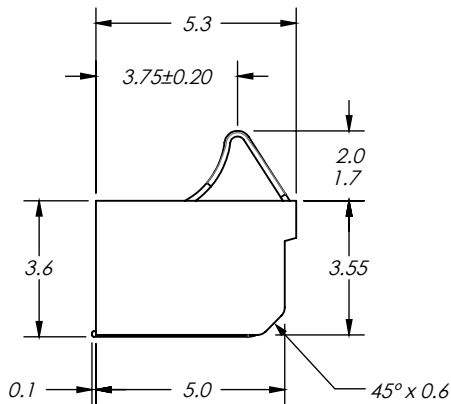
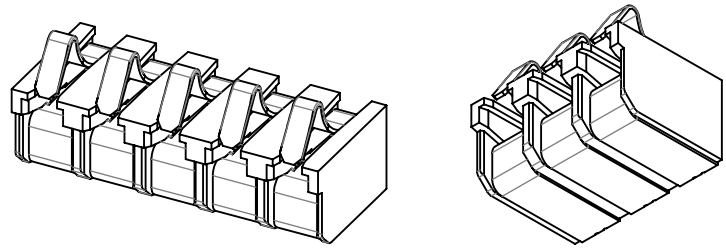

Part Number	Positions	DIM. A	DIM. B	Tape Width
00-9155-002-251-006	2	5.00	2.50	16.0
00-9155-003-251-006	3	7.50	5.00	16.0
00-9155-004-251-006	4	10.00	7.50	24.0
00-9155-005-251-006	5	12.50	10.00	24.0

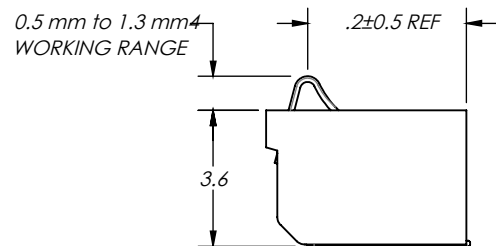

PART AS DEFLECTED

### NOTES:

- FOR MORE DETAILED INFORMATION, SEE KYOCERA AVX PRODUCT SPECIFICATION #201-01-093.
- HOUSING MATERIAL: GLASS-FILLED STANYL 4T; FLAME RETARDANT PER UL94V-0; HALOGEN FREE, COLOR: BLACK.
- CONTACT MATERIAL: BERYLLIUM-COPPER.
- CONTACT PLATING: NICKEL UNDERPLATE ALL OVER; 0.4 μ-m MIN. GOLD IN CONTACT AREA; LEAD-FREE TIN ON TAILS.
- 2.20 x 5.00 SOLDER PADS MAY BE CONTINUOUS, OR THE SHADED PORTION MAY BE REMOVED—AT CUSTOMER'S DISCRETION.



# BATTERY CONNECTORS

## Reduced 2.5mm Pitch 9155-250

RECOMMENDED LAYOUT  
SOLDER SIDE PCB

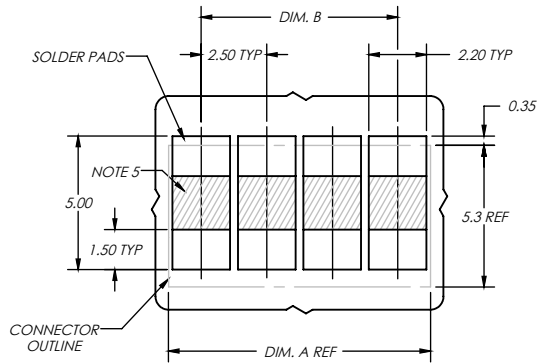

RECOMMENDED LAYOUT  
MATING SIDE PCB

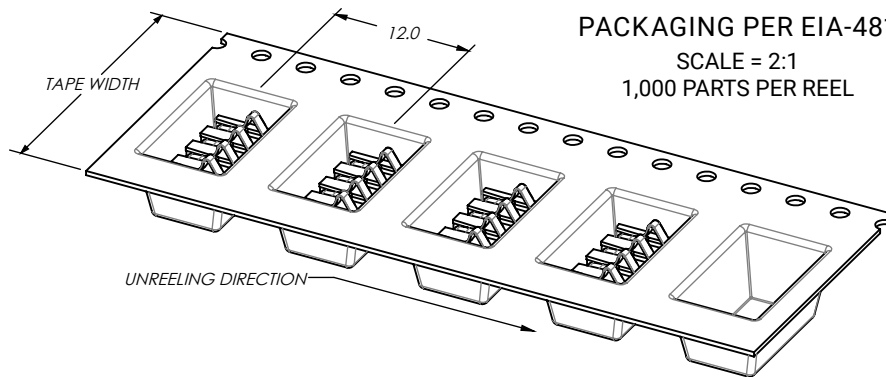
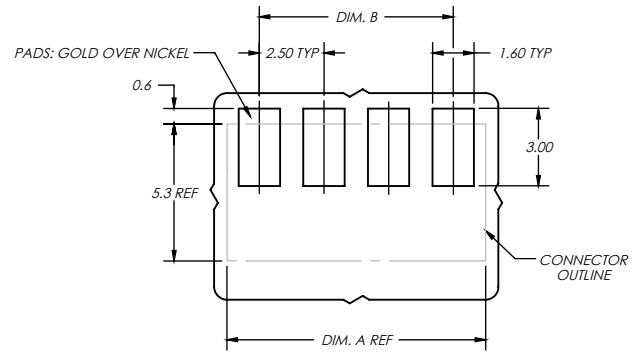

Part Number	Positions	DIM. A	DIM. B	Tape Width
00-9155-002-251-006	2	5.00	2.50	16.0
00-9155-003-251-006	3	7.50	5.00	16.0
00-9155-004-251-006	4	10.00	7.50	24.0
00-9155-005-251-006	5	12.50	10.00	24.0

**NOTES:**

1. FOR MORE DETAILED INFORMATION, SEE KYOCERA AVX PRODUCT SPECIFICATION #201-01-093.
2. HOUSING MATERIAL: GLASS-FILLED STANYL 4T; FLAME RETARDANT PER UL94V-0; HALOGEN FREE, COLOR: BLACK.
3. CONTACT MATERIAL: BERYLLIUM-COPPER.
4. CONTACT PLATING: NICKEL UNDERPLATE ALL OVER; 0.4 μ-m MIN. GOLD IN CONTACT AREA; LEAD-FREE TIN ON TAILS.
5. 2.20 x 5.00 SOLDER PADS MAY BE CONTINUOUS, OR THE SHADED PORTION MAY BE REMOVED—AT CUSTOMER'S DISCRETION.

# BATTERY CONNECTORS

## Right Angle 3.0mm Pitch 9155-300



A further addition to the battery connector range offered by KYOCERA AVX is a 90 degree version. On a 3mm pitch, offered in 2 to 6 contact positions and rated as with all of the battery range at 3 amps. The connector's design is small and compact to minimize its profile yet stable while having a contact point 4.61mm above the PCB.

The stability comes from the addition of extra SMT anchor brackets that are in between the SMT contact pads and both at the front of the connector and within the row of the contact SMT pads.

As with the other 9155 series of battery connectors offered by KYOCERA AVX the 90 degree version is rated at 3 amps and 5000 mating cycles, RoHS compliant and using high temperature plastic enables the connectors to be processed at up to 260°C.

### APPLICATIONS

- Mobile phones
- Digital music players
- Hand held terminals
- Data terminals or any other small portable device

### FEATURES AND BENEFITS

- Simple designed spring contact
- End to end stackable for larger pin counts
- Additional contact anchor brackets to added stability on the PCB
- Robust to shock and vibration
- Selectively plated contact area

### ELECTRICAL

- Current Rating: 3 Amp / Contact
- Voltage Rating: 125 VAC

### ENVIRONMENTAL

- Operating Temperature: -40°C to +125°C

### MECHANICAL

- Insulator Material: Glass-Filled Nylon 46; UL94 HB
- Contact Material: Beryllium Copper
- Plating: Gold over Nickel
- Durability: 5000 Cycles

### HOW TO ORDER

<b>00</b>	<b>9155</b>	<b>00X</b>
Prefix	Series	No. of Ways
		2 = 002
		3 = 003
		4 = 004
		5 = 005
		6 = 006

<b>301</b>				
Right Angle Battery Connector				
<table border="1"> <thead> <tr> <th>Code</th> <th>Description</th> </tr> </thead> <tbody> <tr> <td>301</td> <td>Right Angle 3.00mm Battery Connector</td> </tr> </tbody> </table>	Code	Description	301	Right Angle 3.00mm Battery Connector
Code	Description			
301	Right Angle 3.00mm Battery Connector			

<b>00X</b>						
Plating Option						
<table border="1"> <thead> <tr> <th>Code</th> <th>Description</th> </tr> </thead> <tbody> <tr> <td>006</td> <td>0.4µm Selective Gold, Standard</td> </tr> <tr> <td>008</td> <td>0.8µm Selective Gold, Special Order</td> </tr> </tbody> </table>	Code	Description	006	0.4µm Selective Gold, Standard	008	0.8µm Selective Gold, Special Order
Code	Description					
006	0.4µm Selective Gold, Standard					
008	0.8µm Selective Gold, Special Order					



# BATTERY CONNECTORS

## Right Angle 3.0mm Pitch 9155-300

### 2 WAY RIGHT ANGLE BATTERY CONNECTOR

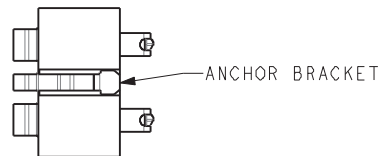
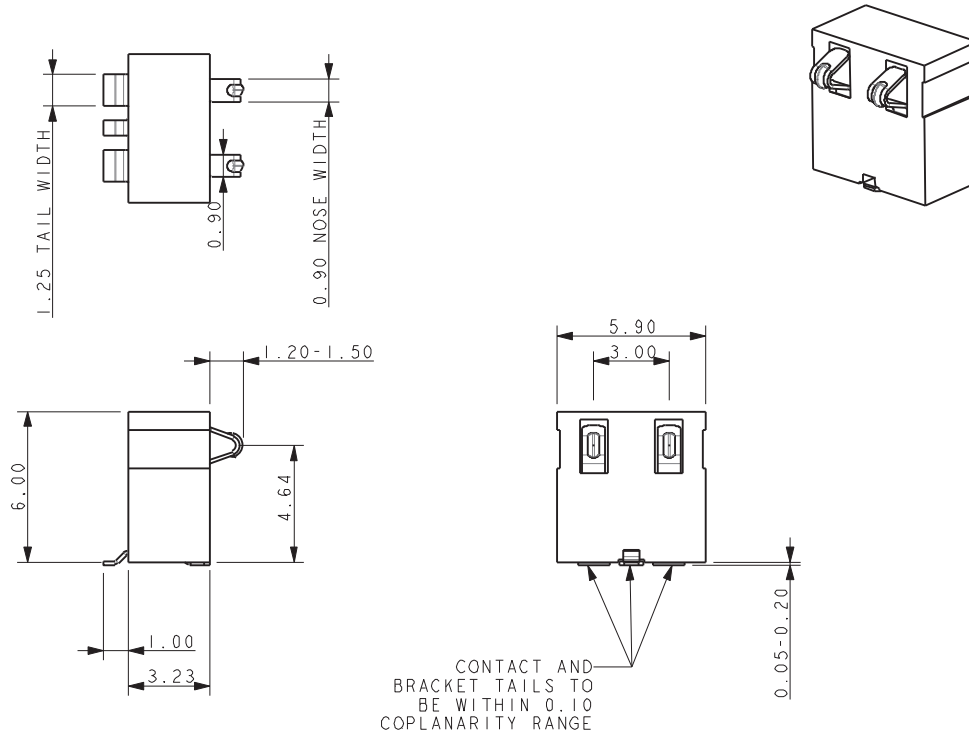

### PCB LAYOUT

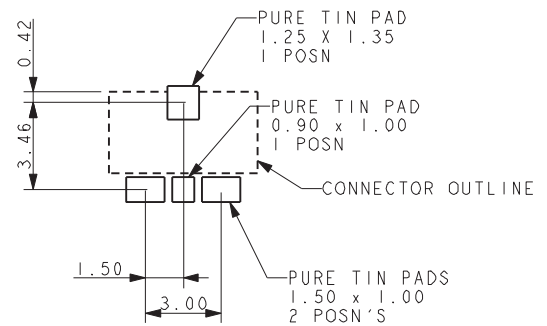

### PACKING DETAILS

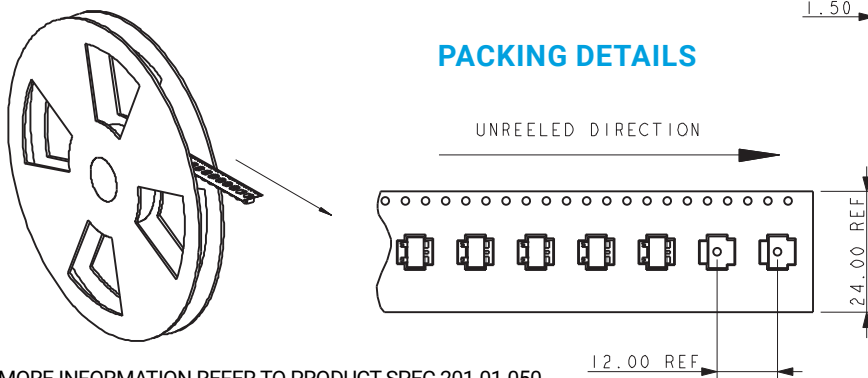

REEL QTY	800
LEADER	480MM
TRAILER	480MM

#### NOTES:

1. FOR MORE INFORMATION REFER TO PRODUCT SPEC 201-01-050.
2. GENERAL TOLERANCE  $\pm 0.20$  UNLESS OTHERWISE STATED.
3. FOR MATING PAD DETAILS REFER TO PAGE 29.
4. INSULATOR MATERIAL: 30% GLASS FILLED NYLON 46, UL94 V-O. COLOR BLACK.
5. CONTACT MATERIAL: BERYLLIUM COPPER.
6. CONTACT PLATING: SELECTIVE GOLD OVER NICKEL. PURE TIN ON TAILS.
7. BRACKET MATERIAL: PHOSPHOR BRONZE.
8. BRACKET PLATING: PURE TIN OVER NICKEL.

# BATTERY CONNECTORS

## Right Angle 3.0mm Pitch 9155-300

### 3 WAY RIGHT ANGLE BATTERY CONNECTOR

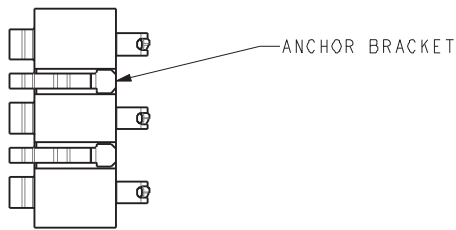
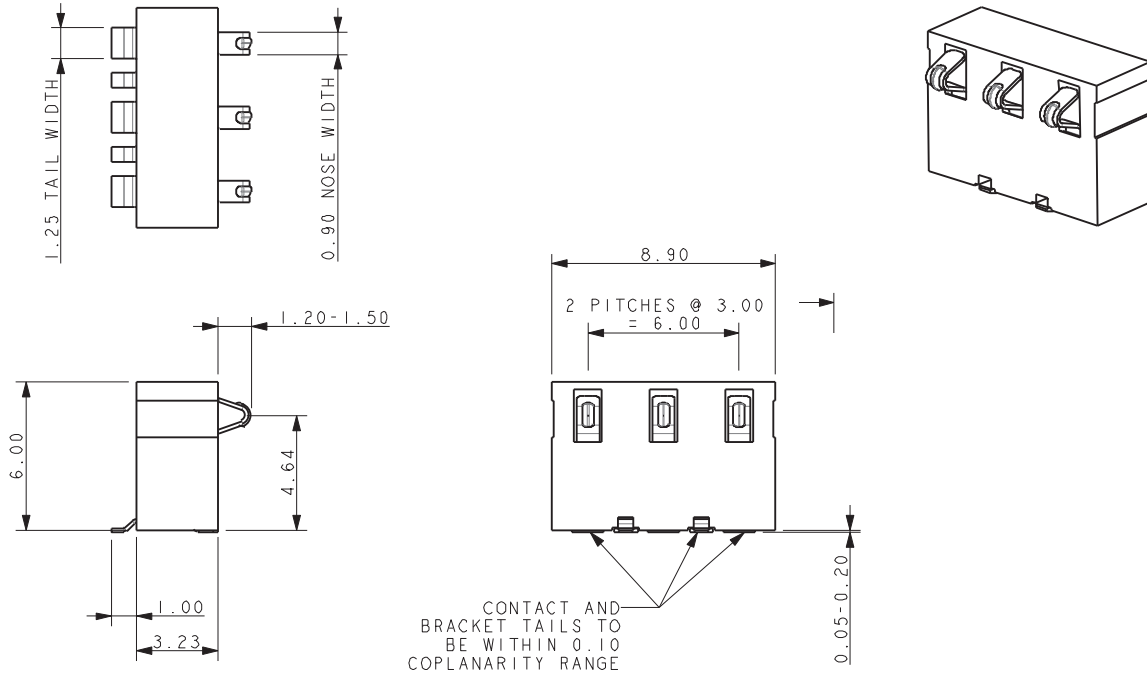

### PCB LAYOUT

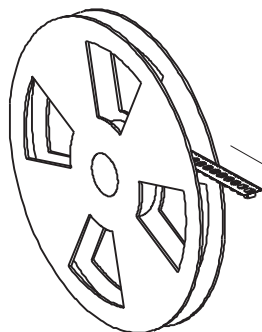
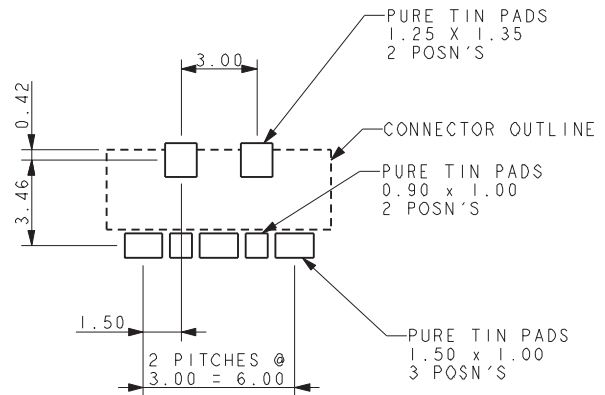

### PACKING DETAILS

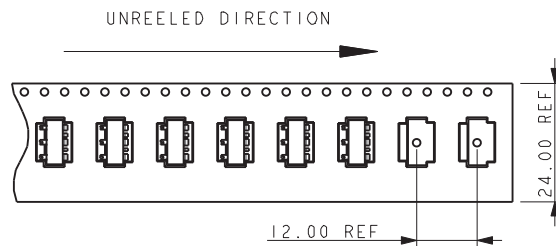

REEL QTY	800
LEADER	480MM
TRAILER	480MM

#### NOTES:

- FOR MORE INFORMATION REFER TO PRODUCT SPEC 201-01-050.
- GENERAL TOLERANCE  $\pm 0.20$  UNLESS OTHERWISE STATED.
- FOR MATING PAD DETAILS REFER TO PAGE 29.
- INSULATOR MATERIAL: 30% GLASS FILLED NYLON 46, UL94 V-O. COLOR BLACK.
- CONTACT MATERIAL: BERYLLIUM COPPER.
- CONTACT PLATING: SELECTIVE GOLD OVER NICKEL. PURE TIN ON TAILS.
- BRACKET MATERIAL: PHOSPHOR BRONZE.
- BRACKET PLATING: PURE TIN OVER NICKEL.

# BATTERY CONNECTORS

## Right Angle 3.0mm Pitch 9155-300

### 4 WAY RIGHT ANGLE BATTERY CONNECTOR

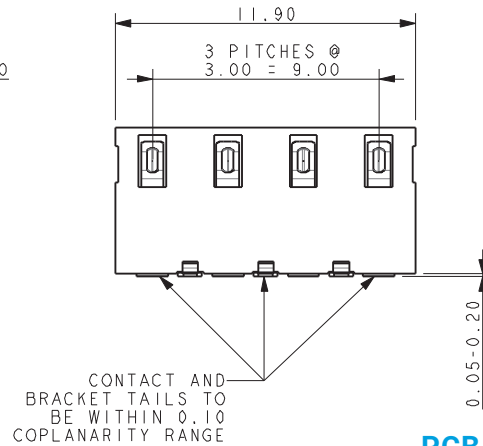
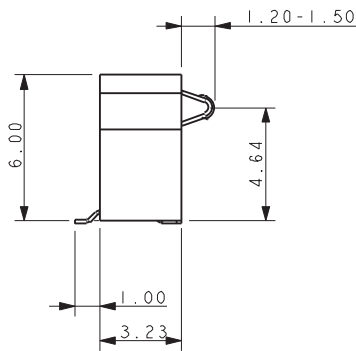
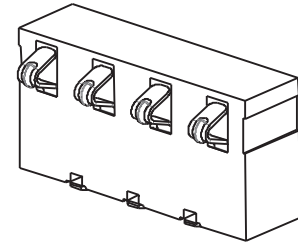
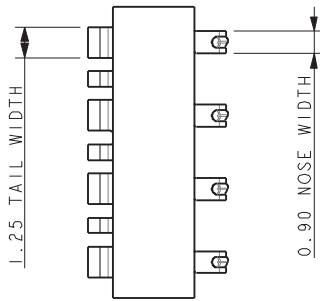

### PCB LAYOUT

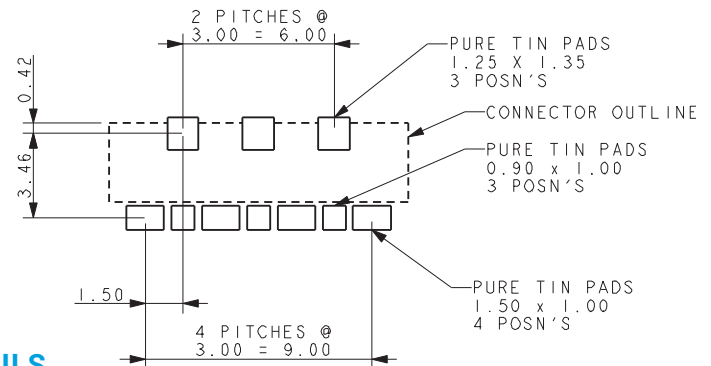
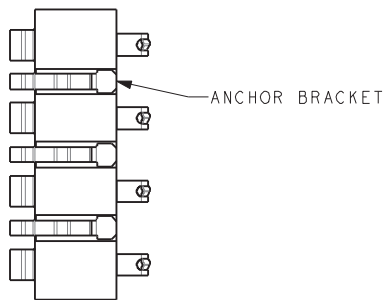

### PACKING DETAILS

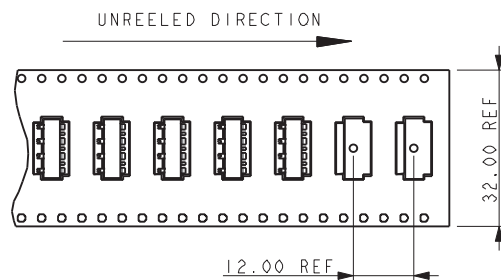
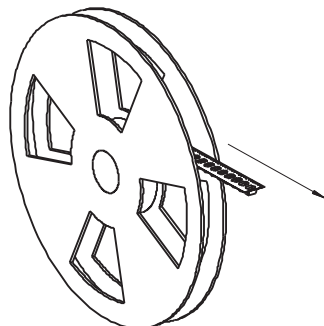

REEL QTY	800
LEADER	480MM
TRAILER	480MM

#### NOTES:

- FOR MORE INFORMATION REFER TO PRODUCT SPEC 201-01-050.
- GENERAL TOLERANCE  $\pm 0.20$  UNLESS OTHERWISE STATED.
- FOR MATING PAD DETAILS REFER TO PAGE 29.
- INSULATOR MATERIAL: 30% GLASS FILLED NYLON 46, UL94 V-O. COLOR BLACK.
- CONTACT MATERIAL: BERYLLIUM COPPER.
- CONTACT PLATING: SELECTIVE GOLD OVER NICKEL. PURE TIN ON TAILS.
- BRACKET MATERIAL: PHOSPHOR BRONZE.
- BRACKET PLATING: PURE TIN OVER NICKEL.

# BATTERY CONNECTORS

## Right Angle 3.0mm Pitch 9155-300

### 5 WAY RIGHT ANGLE BATTERY CONNECTOR

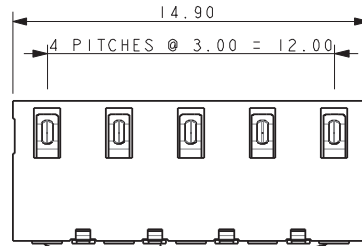
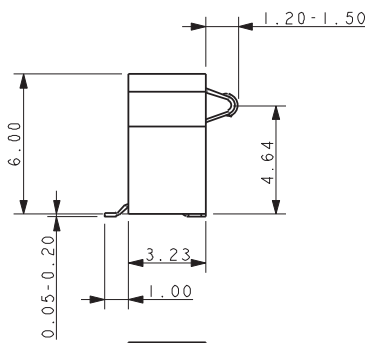
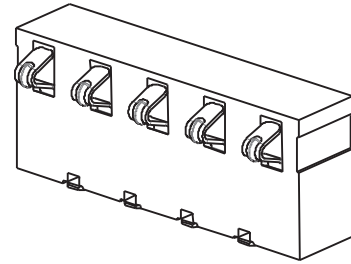
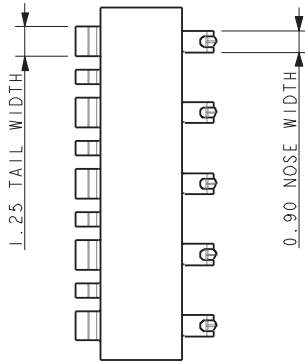

CONTACT AND BRACKET TAILS TO BE WITHIN 0.10 COPLANARITY RANGE

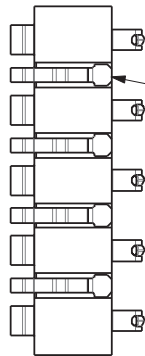

ANCHOR BRACKET

### PCB LAYOUT

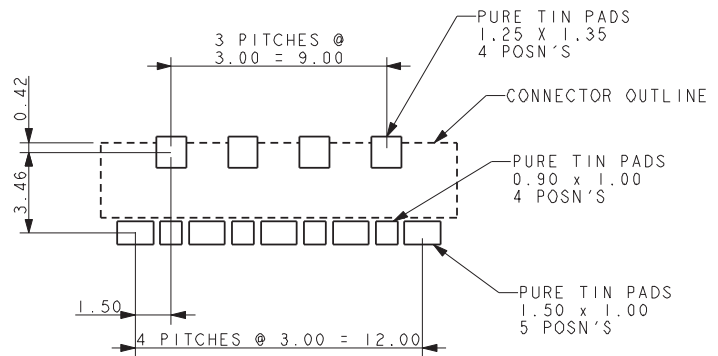

### PACKING DETAILS

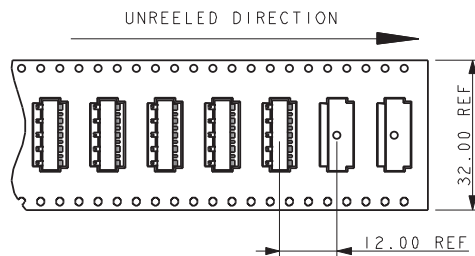
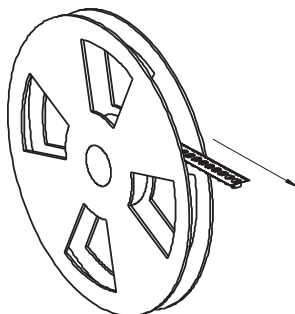

REEL QTY	800
LEADER	480MM
TRAILER	480MM

#### NOTES:

1. FOR MORE INFORMATION REFER TO PRODUCT SPEC 201-01-050.
2. GENERAL TOLERANCE  $\pm 0.20$  UNLESS OTHERWISE STATED.
3. FOR MATING PAD DETAILS REFER TO PAGE 29.
4. INSULATOR MATERIAL: 30% GLASS FILLED NYLON 46, UL94 V-O. COLOR BLACK.
5. CONTACT MATERIAL: BERYLLIUM COPPER.
6. CONTACT PLATING: SELECTIVE GOLD OVER NICKEL. PURE TIN ON TAILS.
7. BRACKET MATERIAL: PHOSPHOR BRONZE.
8. BRACKET PLATING: PURE TIN OVER NICKEL.

# BATTERY CONNECTORS

## Right Angle 3.0mm Pitch 9155-300

### 6 WAY RIGHT ANGLE BATTERY CONNECTOR

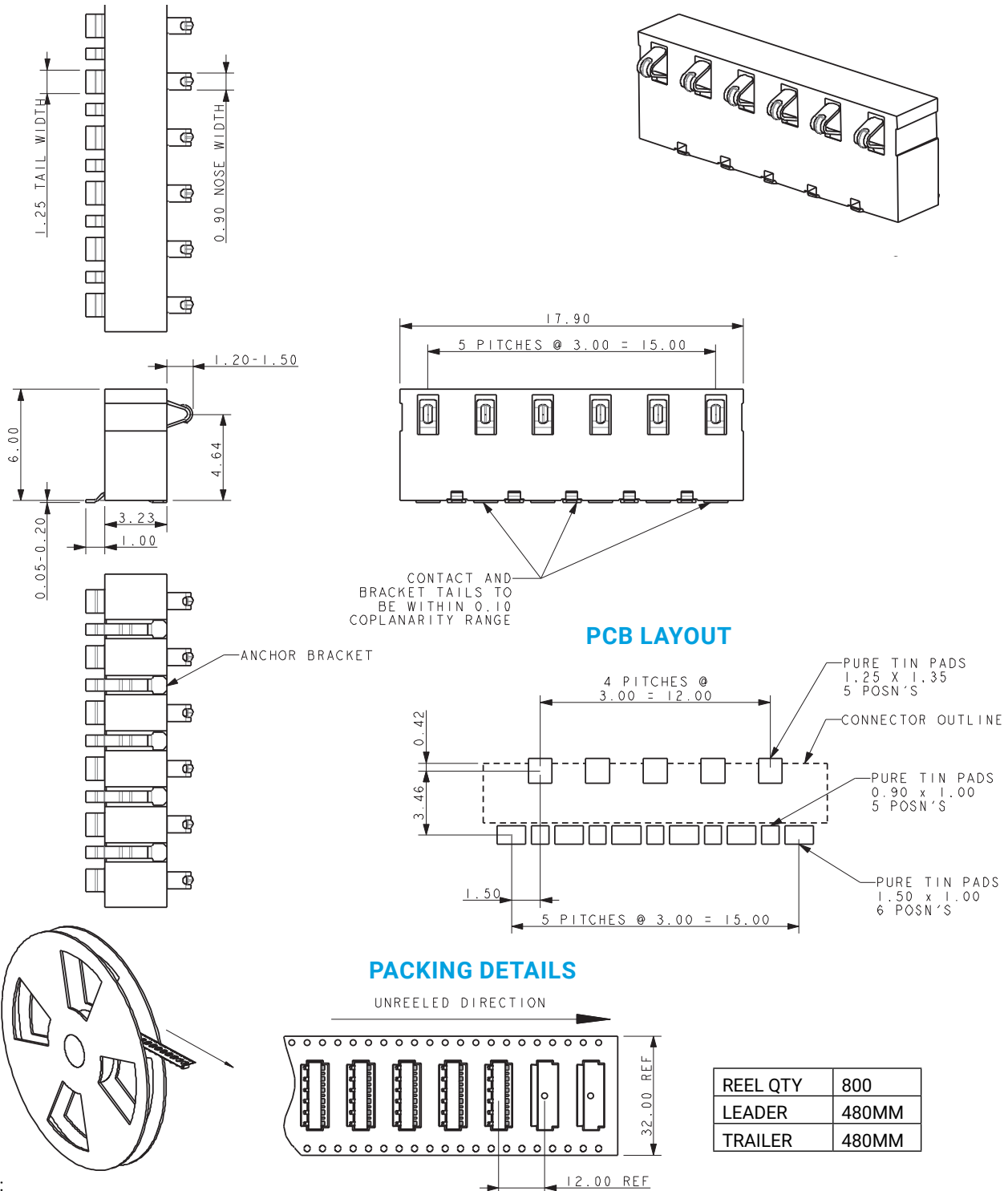

**NOTES:**

1. FOR MORE INFORMATION REFER TO PRODUCT SPEC 201-01-050.
2. GENERAL TOLERANCE  $\pm 0.20$  UNLESS OTHERWISE STATED.
3. FOR MATING PAD DETAILS REFER TO PAGE 29.
4. INSULATOR MATERIAL: 30% GLASS FILLED NYLON 46, UL94 V-O. COLOR BLACK.
5. CONTACT MATERIAL: BERYLLIUM COPPER.
6. CONTACT PLATING: SELECTIVE GOLD OVER NICKEL. PURE TIN ON TAILS.
7. BRACKET MATERIAL: PHOSPHOR BRONZE.
8. BRACKET PLATING: PURE TIN OVER NICKEL.

REEL QTY	800
LEADER	480MM
TRAILER	480MM

**RIGHT ANGLE BATTERY CONNECTOR – MATING PADS**

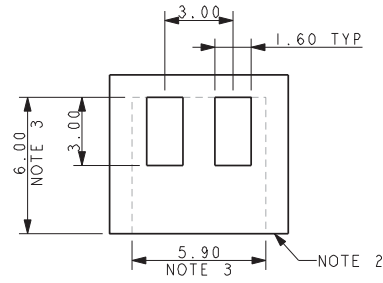

**2 WAY MATING PADS**

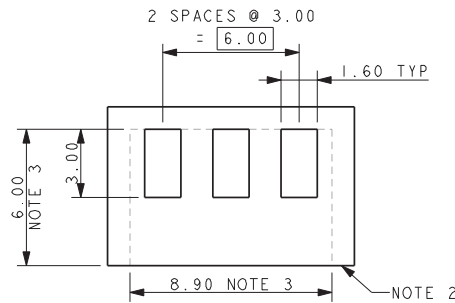

**3 WAY MATING PADS**

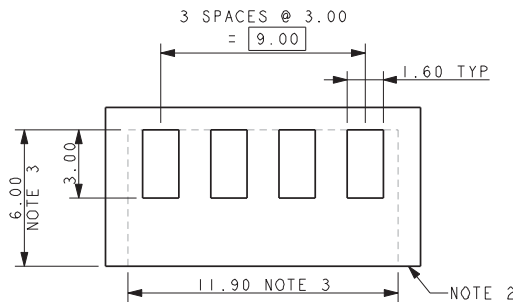

**4 WAY MATING PADS**

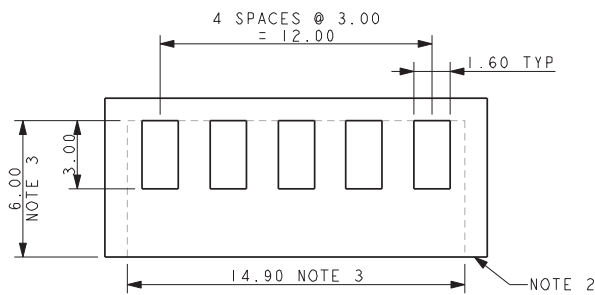

**5 WAY MATING PADS**

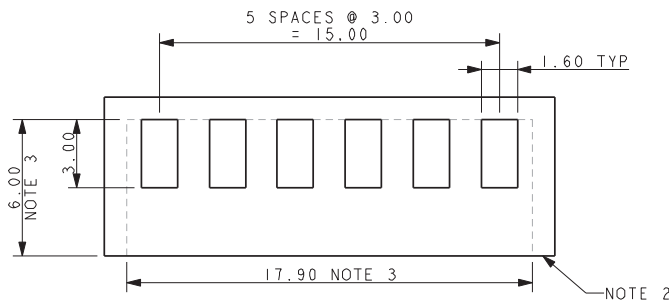

**6 WAY MATING PADS**

**NOTES:**

1. SUGGESTED MATING PADS FOR RIGHT ANGLE BATTERY CONNECTORS.
2. TOP SURFACE OF HORIZONTAL PCB/BASE OF CONNECTOR.
3. OUTLINE OF CONNECTOR.
4. PREFERRED PLATING ON PADS GOLD OVER NICKEL.



# BATTERY CONNECTORS

## Right Angle 2.5mm Pitch 9155-500 .

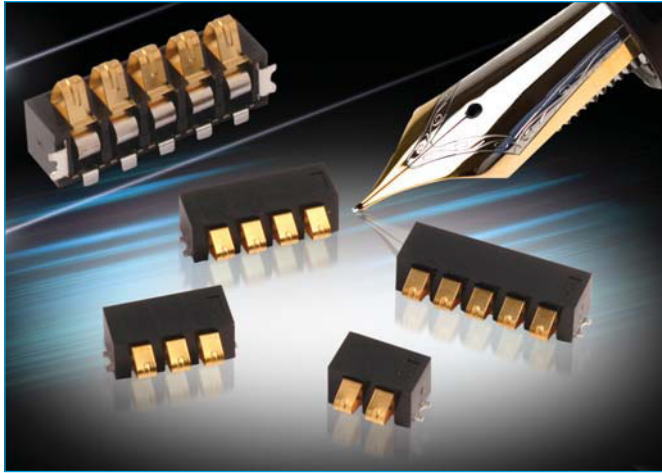

KYOCERA AVX extends the battery connector range with the addition of a low profile 2.5mm pitch right angle connector. This connector is offered in 2 to 5 positions and is rated at 3 amps. The connector's design is small and compact to minimize its profile yet functionally stable having a contact point at 2.20mm above the PCB.

The unique design of this stamped contact allows for a maximum insulator height of 4.0mm which makes it size compatible with more expensive pogo pin style battery connectors.

The complete family of battery connectors from KYOCERA AVX offer all of the same advantages; Beryllium Copper base material for enhanced contact performance, a full 3 amp current rating, selective gold plating for 5000 mating cycles and high temperature plastic for RoHS soldering.

### APPLICATIONS

- Mobile Phones
- Digital Music Players
- Any Handheld Devices

### FEATURES AND BENEFITS

- Reliable stamped contact with coined nose
- Full 1.5mm nose deflection for large operating range
- Two anchor tabs for mechanical stability
- 5000 cycle durability rating
- Minimized X, Y and Z package dimensions

### ELECTRICAL

- Current Rating: 3 Amp / Contact
- Voltage Rating: 125 VAC

### ENVIRONMENTAL

- Operating Temperature: -40°C to +125°C

### MECHANICAL

- Insulator Material: Glass-Filled Nylon 46; UL94 HB
- Contact Material: Beryllium Copper
- Plating: Gold over Nickel
- Durability: 5000 Cycles

### HOW TO ORDER

<b>00</b>	<b>9155</b>	<b>00X</b>
Prefix	Series	No. of Ways
		2 = 002
		3 = 003
		4 = 004
		5 = 005

<b>541</b>				
Right Angle Battery Connector				
<table border="1"> <thead> <tr> <th>Code</th> <th>Description</th> </tr> </thead> <tbody> <tr> <td>541</td> <td>Right Angle 2.5mm Battery Connector</td> </tr> </tbody> </table>	Code	Description	541	Right Angle 2.5mm Battery Connector
Code	Description			
541	Right Angle 2.5mm Battery Connector			

<b>00X</b>						
Plating Option						
<table border="1"> <thead> <tr> <th>Code</th> <th>Description</th> </tr> </thead> <tbody> <tr> <td>006</td> <td>0.4µm Selective Gold, Standard</td> </tr> <tr> <td>008</td> <td>0.8µm Selective Gold, Special Order</td> </tr> </tbody> </table>	Code	Description	006	0.4µm Selective Gold, Standard	008	0.8µm Selective Gold, Special Order
Code	Description					
006	0.4µm Selective Gold, Standard					
008	0.8µm Selective Gold, Special Order					



# BATTERY CONNECTORS

## Right Angle 2.5mm Pitch 9155-500 .

### 2 WAY RIGHT ANGLE BATTERY CONNECTOR

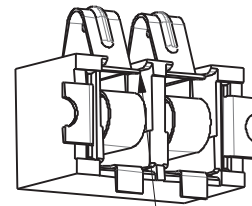
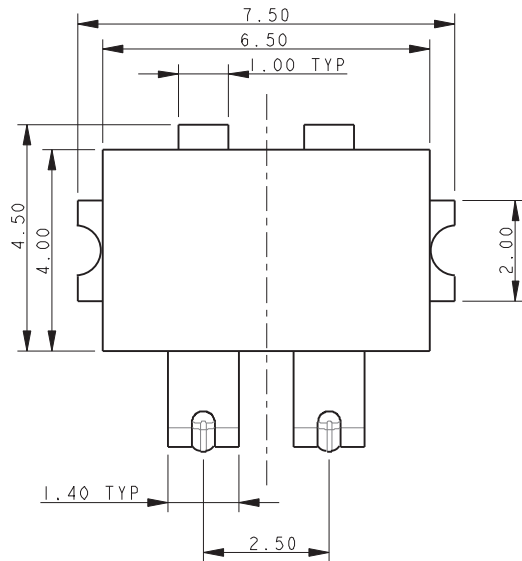

CONTACT NOSE RETAINED ANTI-SNAG FEATURE

### DEFLECTIVE CONNECTOR

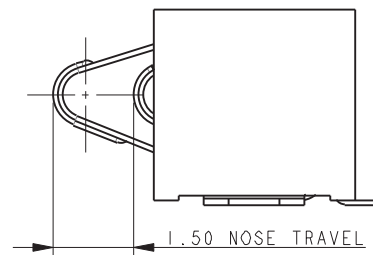

### UNDEFLECTED CONTACT

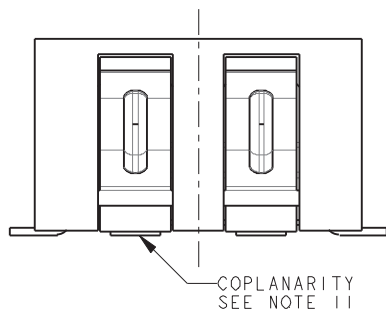
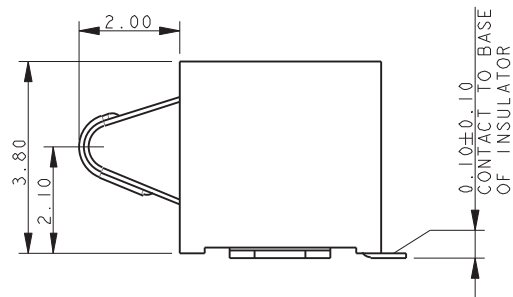

COPLANARITY SEE NOTE 11

### SUGGESTED PCB LAYOUT

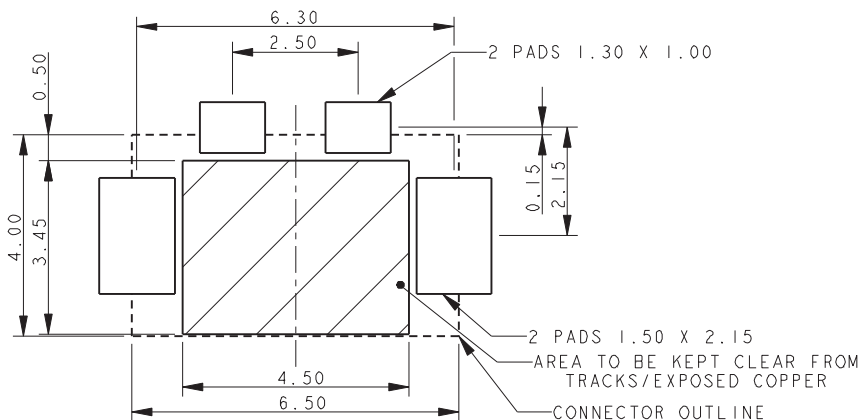

#### NOTES:

1. GENERAL TOLERANCE  $\pm 0.20$  UNLESS OTHERWISE STATED.
2. FOR FULL PRODUCT SPECIFICATION REFER TO ELCO SPEC 201-01-114.
3. FOR MATING PAD DETAILS REFER TO PAGE 36.
4. PACKING DETAILS ON PAGE 35.
5. INSULATOR MATERIAL: 30% GLASS FILLED NYLON 46, UL94 V-0. COLOR BLACK.
6. CONTACT MATERIAL: BERYLLIUM COPPER.
7. CONTACT PLATING: SELECTIVE GOLD OVER NICKEL, PURE TIN ON TAILS.
8. BRACKET MATERIAL: PHOSPHOR BRONZE.
9. BRACKET PLATING: PURE TIN OVER NICKEL.
10. NOMINAL CONTACT FORCE 140 GRAMS AT 1.50 DEFLECTION.
11. COPLANARITY OF ALL CONTACT TAILS AND PADS 0.10MM MAXIMUM.

# BATTERY CONNECTORS

Right Angle 2.5mm Pitch 9155-500 .

## 3 WAY RIGHT ANGLE BATTERY CONNECTOR

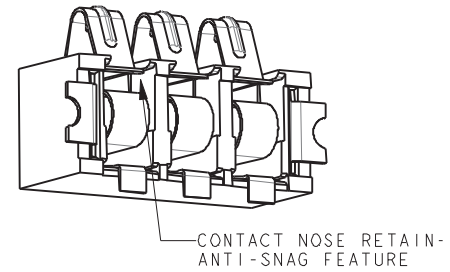
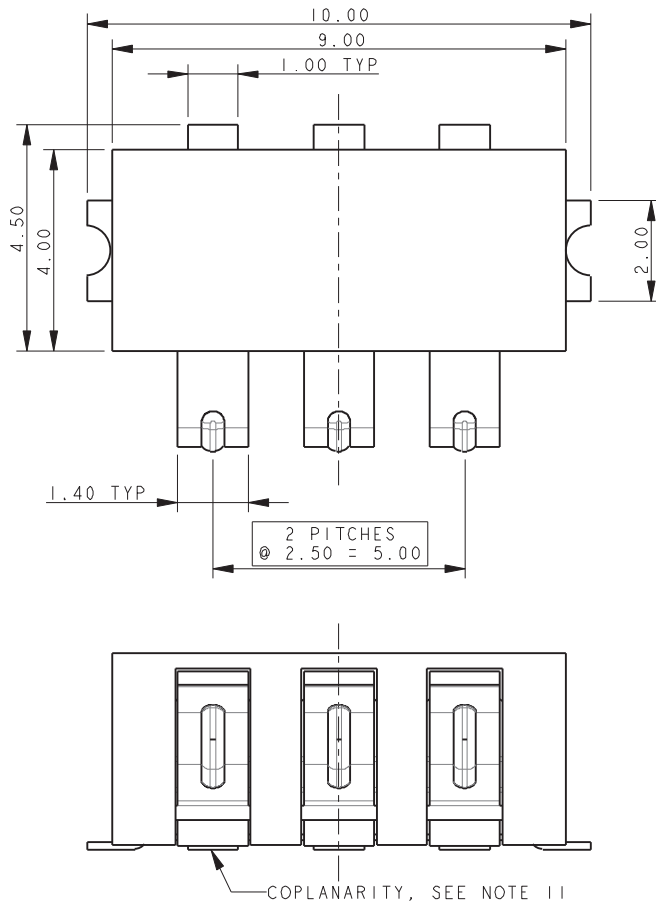

## DEFLECTIVE CONNECTOR

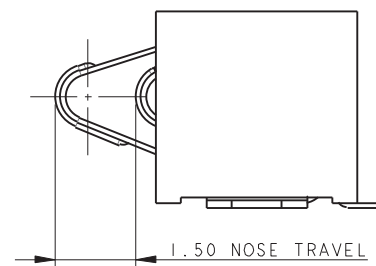

## UNDEFLECTED CONTACT

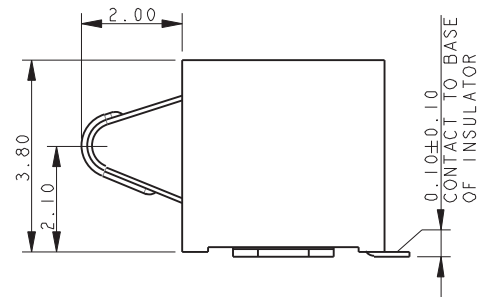

## SUGGESTED PCB LAYOUT

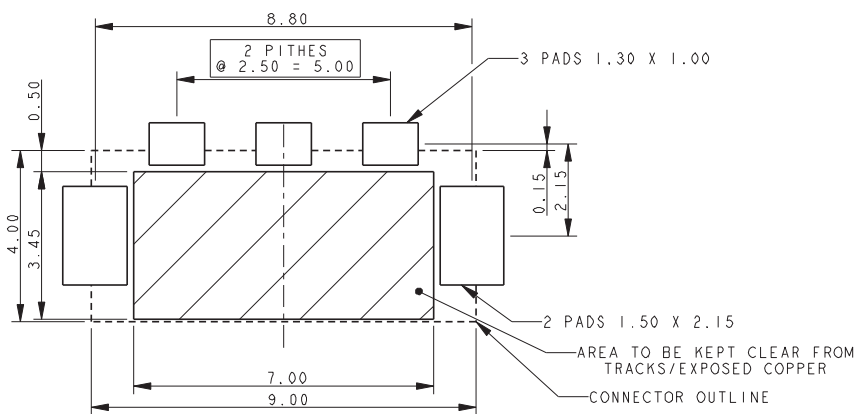

### NOTES:

1. GENERAL TOLERANCE  $\pm 0.20$  UNLESS OTHERWISE STATED.
2. FOR FULL PRODUCT SPECIFICATION REFER TO ELCO SPEC 201-01-114.
3. FOR MATING PAD DETAILS REFER TO PAGE 36.
4. PACKING DETAILS ON PAGE 35.
5. INSULATOR MATERIAL: 30% GLASS FILLED NYLON 46, UL94 V-O. COLOR BLACK.
6. CONTACT MATERIAL: BERYLLIUM COPPER.
7. CONTACT PLATING: SELECTIVE GOLD OVER NICKEL, PURE TIN ON TAILS.
8. BRACKET MATERIAL: PHOSPHOR BRONZE.
9. BRACKET PLATING: PURE TIN OVER NICKEL.
10. NOMINAL CONTACT FORCE 140 GRAMS AT 1.50 DEFLECTION.
11. COPLANARITY OF ALL CONTACT TAILS AND PADS 0.10MM MAXIMUM.

# BATTERY CONNECTORS

## Right Angle 2.5mm Pitch 9155-500 .

### 4 WAY RIGHT ANGLE BATTERY CONNECTOR

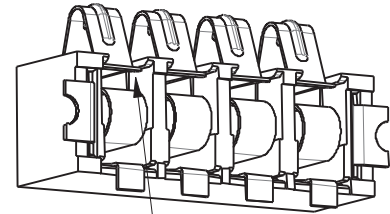
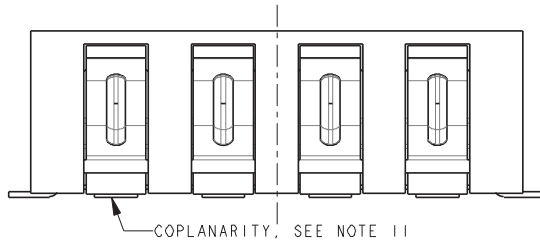
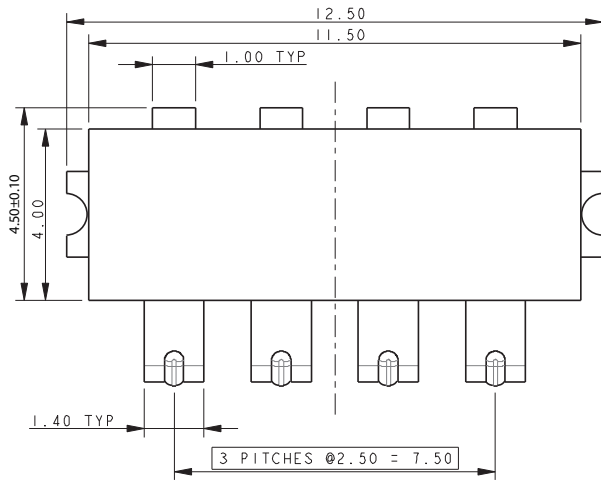

CONTACT NOSE RETAINED ANTI-SNAG FEATURE

### DEFLECTIVE CONNECTOR

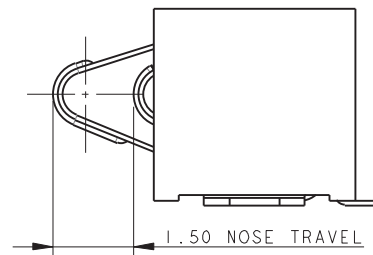

### UNDEFLECTED CONTACT

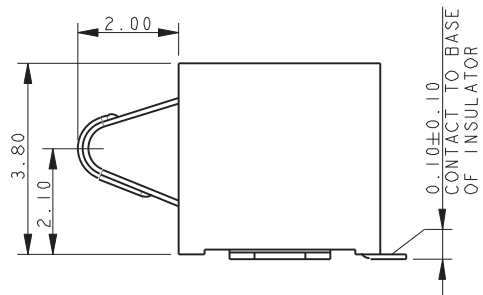

### SUGGESTED PCB LAYOUT

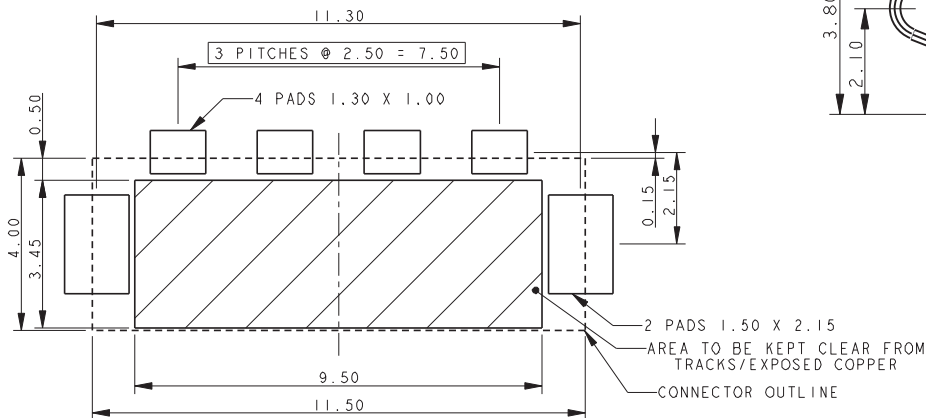

#### NOTES:

1. GENERAL TOLERANCE  $\pm 0.20$  UNLESS OTHERWISE STATED.
2. FOR FULL PRODUCT SPECIFICATION REFER TO ELCO SPEC 201-01-114.
3. FOR MATING PAD DETAILS REFER TO PAGE 36.
4. PACKING DETAILS ON PAGE 35.
5. INSULATOR MATERIAL: 30% GLASS FILLED NYLON 46, UL94 V-0. COLOR BLACK.
6. CONTACT MATERIAL: BERYLLIUM COPPER.
7. CONTACT PLATING: SELECTIVE GOLD OVER NICKEL, PURE TIN ON TAILS.
8. BRACKET MATERIAL: PHOSPHOR BRONZE.
9. BRACKET PLATING: PURE TIN OVER NICKEL.
10. NOMINAL CONTACT FORCE 140 GRAMS AT 1.50 DEFLECTION.
11. CONPLANARITY OF ALL CONTACT TAILS AND PADS 0.10MM MAXIMUM.

# BATTERY CONNECTORS

## Right Angle 2.5mm Pitch 9155-500 .

### 5 WAY RIGHT ANGLE BATTERY CONNECTOR

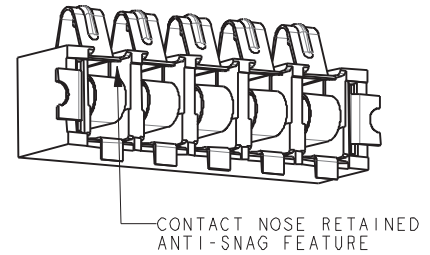
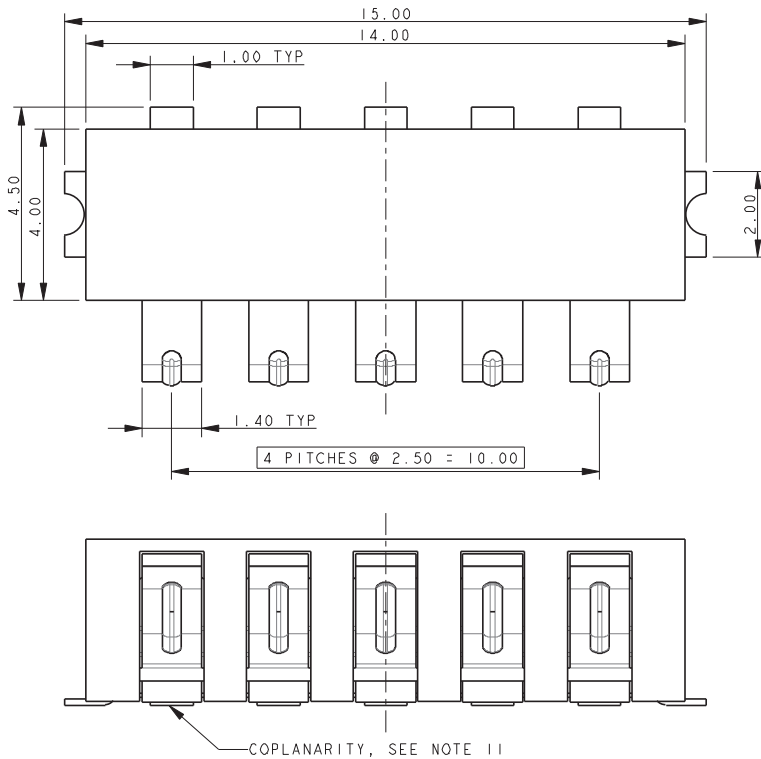

### DEFLECTIVE CONNECTOR

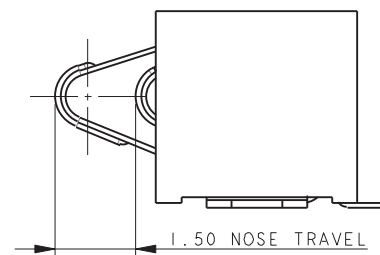

### UNDEFLECTED CONTACT

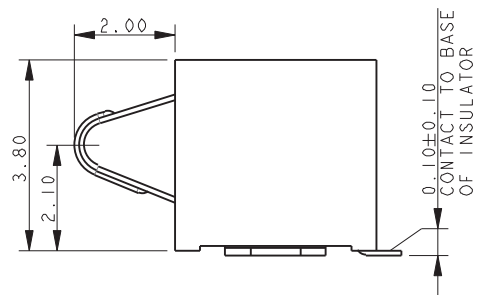

### SUGGESTED PCB LAYOUT

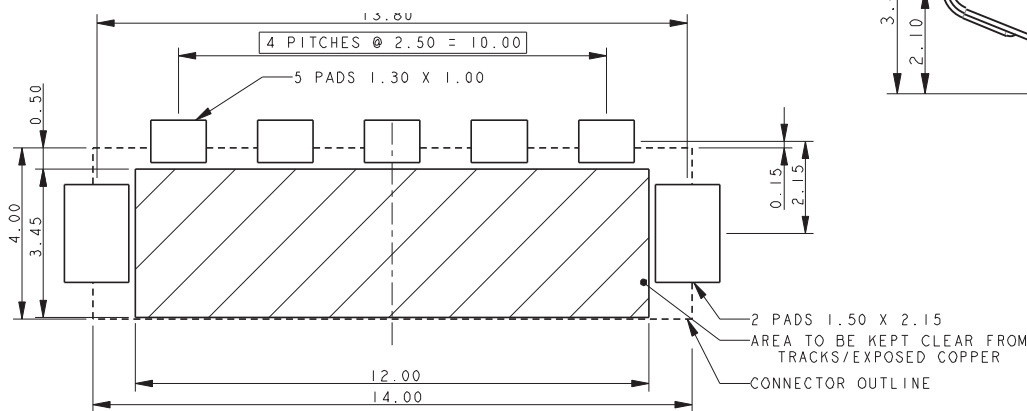

#### NOTES:

1. GENERAL TOLERANCE  $\pm 0.20$  UNLESS OTHERWISE STATED.
2. FOR FULL PRODUCT SPECIFICATION REFER TO ELCO SPEC 201-01-114.
3. FOR MATING PAD DETAILS REFER TO PAGE 36.
4. PACKING DETAILS ON PAGE 35.
5. INSULATOR MATERIAL: 30% GLASS FILLED NYLON 46, UL94 V-O. COLOR BLACK.
6. CONTACT MATERIAL: BERYLLIUM COPPER.
7. CONTACT PLATING: SELECTIVE GOLD OVER NICKEL, PURE TIN ON TAILS.
8. BRACKET MATERIAL: PHOSPHOR BRONZE.
9. BRACKET PLATING: PURE TIN OVER NICKEL.
10. NOMINAL CONTACT FORCE 140 GRAMS AT 1.50 DEFLECTION.
11. CONPLANARITY OF ALL CONTACT TAILS AND PADS 0.10MM MAXIMUM.

# BATTERY CONNECTORS

Right Angle 2.5mm Pitch 9155-500 .

## PACKING DETAILS

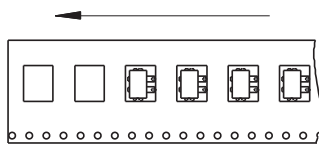
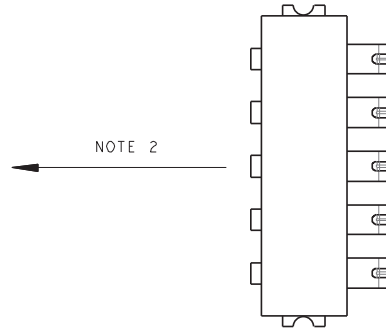

### 2 WAY

REEL QTY	1000
TAPE WIDTH	24MM
POCKET PITCH	12MM

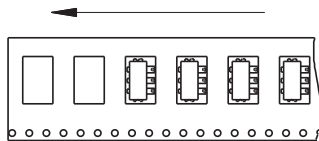

### 3 WAY

REEL QTY	1000
TAPE WIDTH	24MM
POCKET PITCH	12MM

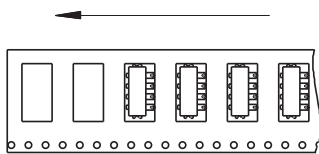

### 4 WAY

REEL QTY	1000
TAPE WIDTH	24MM
POCKET PITCH	12MM

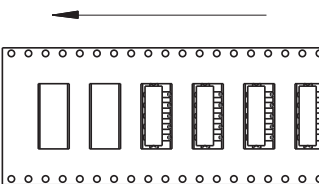

### 5 WAY

REEL QTY	1000
TAPE WIDTH	32MM
POCKET PITCH	12MM

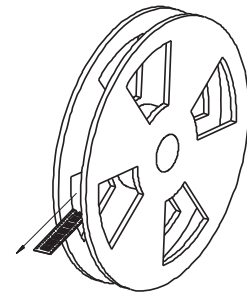

#### NOTES:

1. PARTS TO BE PACKED ON 330MM REELS.
2. COMPONENT ORIENTATION AS SHOWN.

# BATTERY CONNECTORS

Right Angle 2.5mm Pitch 9155-500 .

## STANDARD RIGHT ANGLE – MATING PADS

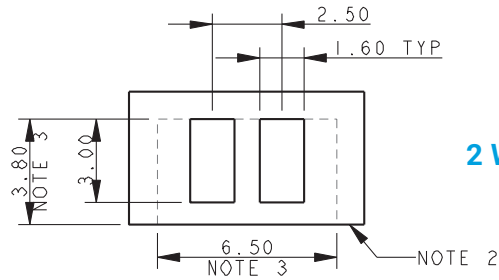

2 WAY MATING PADS

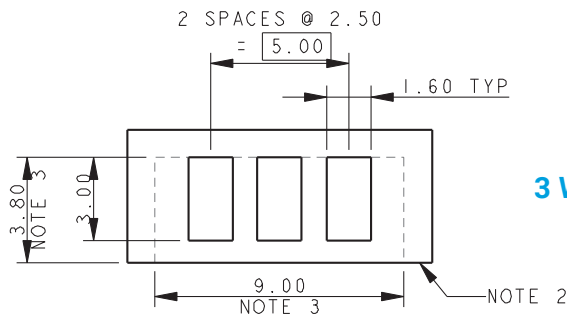

3 WAY MATING PADS

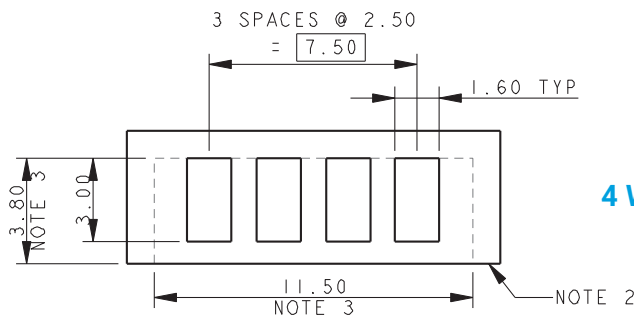

4 WAY MATING PADS

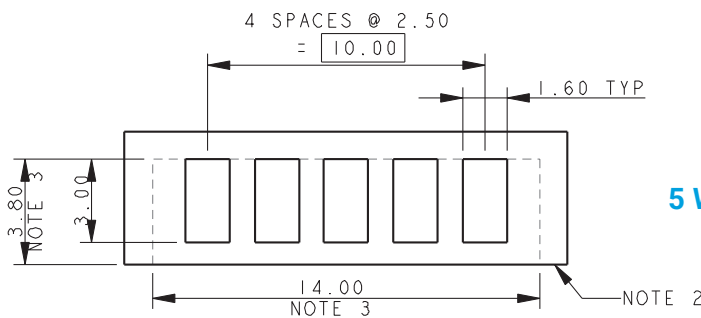

5 WAY MATING PADS

### NOTES:

1. SUGGESTED MATING PADS FOR RIGHT ANGLE BATTERY CONNECTORS.
2. TOP SURFACE OF HORIZONTAL PCB/BASE OF CONNECTOR.
3. OUTLINE OF CONNECTOR.
4. PREFERRED PLATING ON PADS GOLD OVER NICKEL.

# BATTERY CONNECTORS

## Vertical Mate 2.0mm Pitch 9155-800



Traditional battery connectors have been used for years in a number of applications: battery packs, removable or pluggable modules and conventional board-to-board to connect both signal level and power circuits. These ultra reliable and robust gold plated beryllium copper contacts provide high integrity connections in harsh environments.

The vertical mate 9155-800 series eliminates end user damage when pluggable modules or packs are pressed down vertically into a base unit. Traditional right angle connectors have contact geometries that rely on the pack being inserted at an angle and then rotated down into position. The unique contact design of this connector deflects cleanly and easily when a module or mating connector is pushed vertically into position, eliminating any end user damage.

### APPLICATIONS

- Handheld/portable devices requiring docking or cradle charging
- Patient monitoring or portable medical electronics
- Industrial devices requiring pluggable or programming modules
- Internet appliances requiring battery back-up
- Application notes; refer to 201-01-205

### FEATURES AND BENEFITS

- Gold plated BeCu contacts provide high electrical and mechanical performance over 5000 mating cycles
- Unique contact geometry allows for full vertical engagement in pluggable module applications
- Plastic locating bosses and SMT anchor tabs maximizes the mechanical stability of the connector in harsh conditions
- Contact nose incorporates an anti-snag feature to protect during deflection

### ELECTRICAL

- Current Rating: 2p-4p: 2.0 Amps, 5p-6p: 1.5 Amps
- Voltage Rating; 125 VAC

### ENVIRONMENTAL

- Operating Temperature: -40°C to +125°C

### MECHANICAL

- Insulator Material; Glass-Filled Nylon 46; UL94V0
- Contact Material: Beryllium Copper
- Plating: Gold over Nickel, Tin leads
- Durability: 5000 Cycles

### HOW TO ORDER

**00**  
Prefix

**9155**  
Series

**00X**  
No. of Ways

Code	No of Ways	Packing QTY
002	2	1000
003	3	1000
004	4	1000
005	5	1000
006	6	1000

**8XX**  
Standard Battery Connector

852 = Battery Connector Right Angle  
Connector Height: 5.00mm  
Boss: Yes

**00**

**X**  
Plating Option

6 = 0.4µm Selective Gold, Pure Tin Tail  
8 = 0.8µm Selective Gold, Pure Tin Tail





# BATTERY CONNECTORS

## Vertical Mate 2.0mm Pitch 9155-800



### 2 WAY BATTERY CONNECTOR – RIGHT ANGLE 2MM PITCH - WITH BOSS

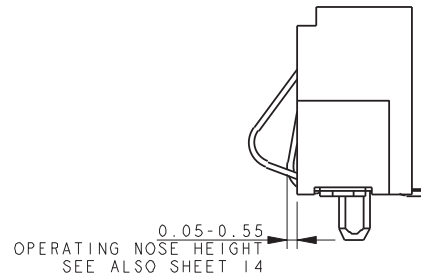
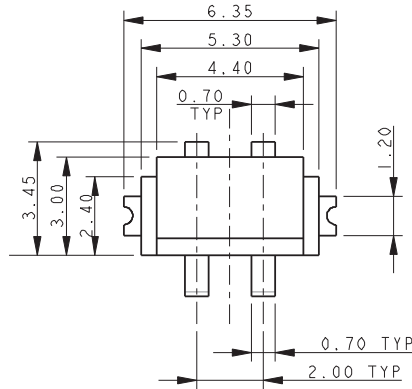

#### DEFLECTED CONTACT

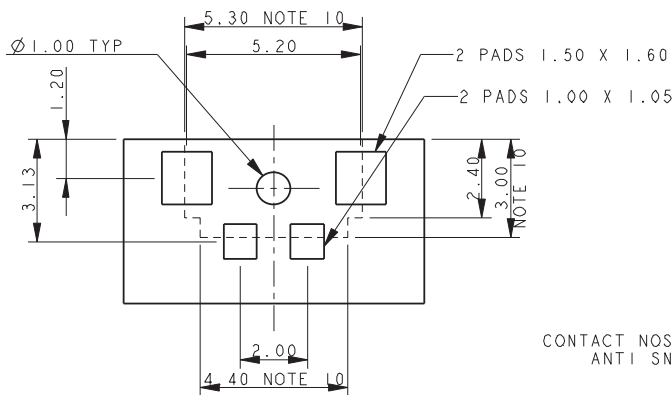
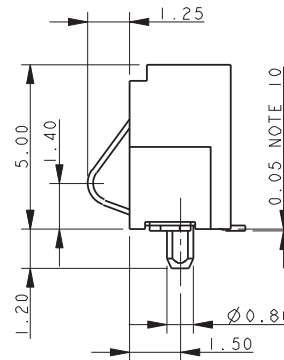
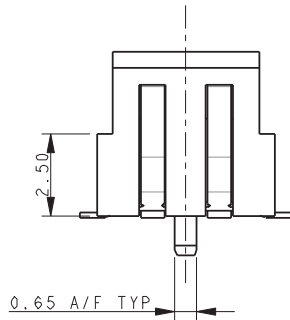

#### SUGGESTED PCB LAYOUT

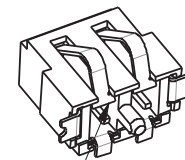

CONTACT NOSE RETAINED  
ANTI SNAG FEATURE

#### NOTES:

1. GENERAL TOLERANCE  $\pm 0.20$  UNLESS STATED.
2. FOR FULL PRODUCT DETAILS REFER TO SPECIFICATION 201-01-2014.  
FOR APPLICATION DATA REFER TO SPECIFICATION 201-01-205.
3. FOR MATING PAD DETAILS REFER TO PAGE 44.
4. FOR PACKING DETAILS REFER TO PAGE 43
5. INSULATION MATERIAL: GLASS FILLED NYLON 46, UL94 V-O, COLOR BLACK.
6. CONTACT MATERIAL: BERYLLIUM COPPER.
7. CONTACT PLATING: SELECTIVE GOLD OVER NICKEL, PURE TIN ON TAILS.
8. BRACKET MATERIAL: TIN PLATED PHOSPHOR BRONZE.
9. CONNECTOR OUTLINE.
10. COPLANARITY ON ALL CONTACT TAILS AND PADS 0.12MM MAXIMUM.

# BATTERY CONNECTORS

## Vertical Mate 2.0mm Pitch 9155-800

### 3 WAY BATTERY CONNECTOR – RIGHT ANGLE 2MM PITCH - WITH BOSS

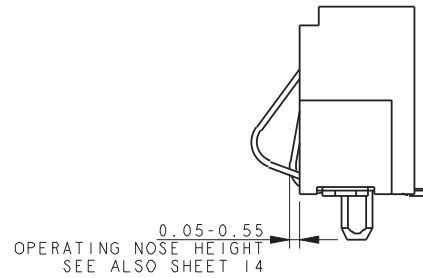
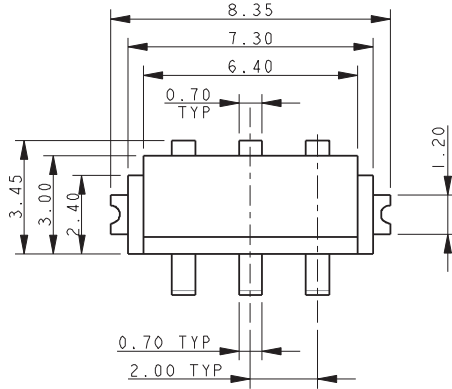

#### DEFLECTED CONTACT

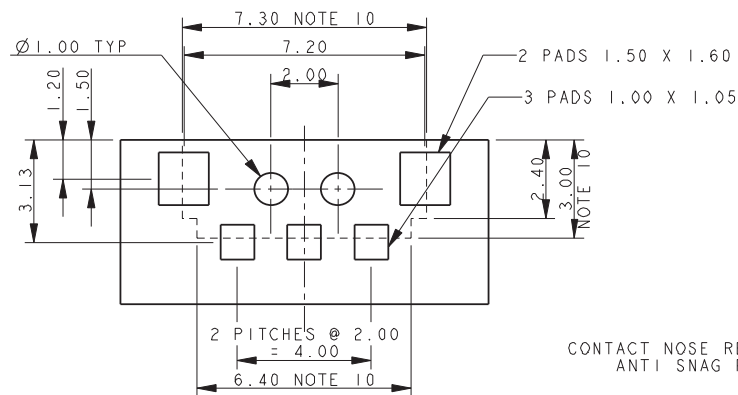
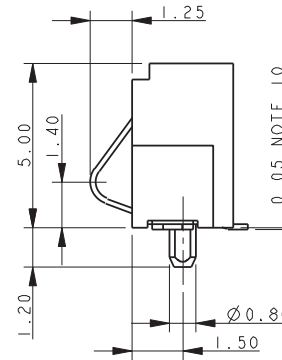
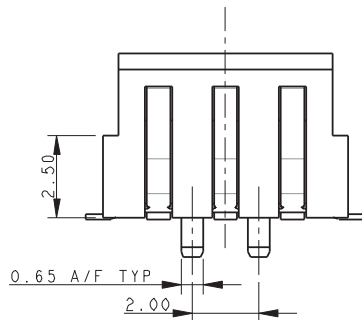

#### SUGGESTED PCB LAYOUT

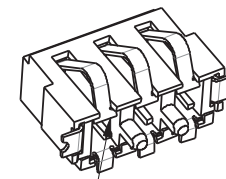

CONTACT NOSE RETAINED  
ANTI SNAG FEATURE

#### NOTES:

1. GENERAL TOLERANCE  $\pm 0.20$  UNLESS STATED.
2. FOR FULL PRODUCT DETAILS REFER TO SPECIFICATION 201-01-2014.  
FOR APPLICATION DATA REFER TO SPECIFICATION 201-01-205.
3. FOR MATING PAD DETAILS REFER TO PAGE 44.
4. FOR PACKING DETAILS REFER TO PAGE 43
5. INSULATION MATERIAL: GLASS FILLED NYLON 46, UL94 V-O, COLOR BLACK.
6. CONTACT MATERIAL: BERYLLIUM COPPER.
7. CONTACT PLATING: SELECTIVE GOLD OVER NICKEL, PURE TIN ON TAILS.
8. BRACKET MATERIAL: TIN PLATED PHOSPHOR BRONZE.
9. CONNECTOR OUTLINE.
10. COPLANARITY ON ALL CONTACT TAILS AND PADS 0.12MM MAXIMUM.

# BATTERY CONNECTORS

## Vertical Mate 2.0mm Pitch 9155-800



### 4 WAY BATTERY CONNECTOR – RIGHT ANGLE 2MM PITCH - WITH BOSS

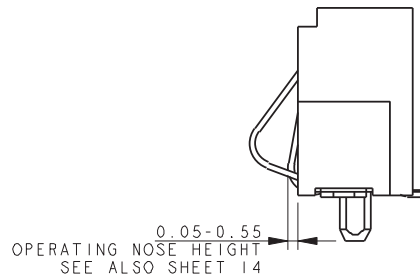
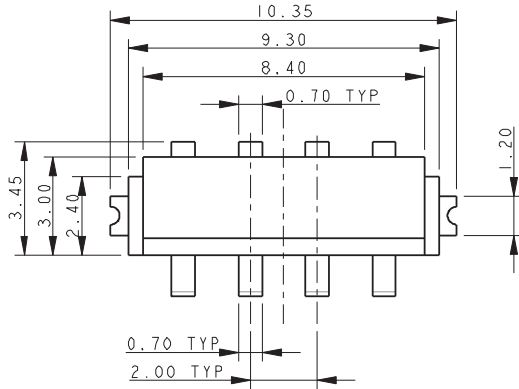

#### DEFLECTED CONTACT

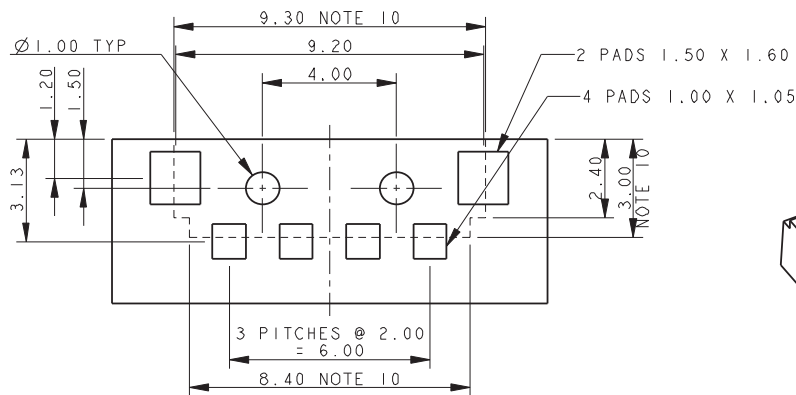
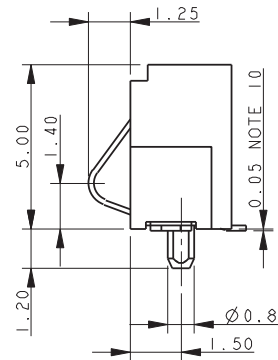
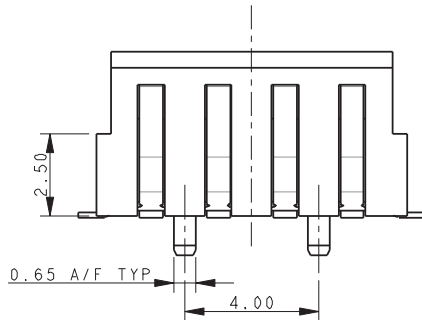

#### SUGGESTED PCB LAYOUT

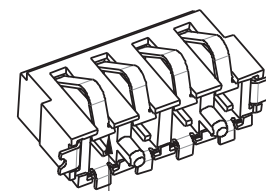

CONTACT NOSE RETAINED  
ANTI SNAG FEATURE

#### NOTES:

1. GENERAL TOLERANCE  $\pm 0.20$  UNLESS STATED.
2. FOR FULL PRODUCT DETAILS REFER TO SPECIFICATION 201-01-2014.  
FOR APPLICATION DATA REFER TO SPECIFICATION 201-01-205.
3. FOR MATING PAD DETAILS REFER TO PAGE 44.
4. FOR PACKING DETAILS REFER TO PAGE 43
5. INSULATION MATERIAL: GLASS FILLED NYLON 46, UL94 V-O, COLOR BLACK.
6. CONTACT MATERIAL: BERYLLIUM COPPER.
7. CONTACT PLATING: SELECTIVE GOLD OVER NICKEL, PURE TIN ON TAILS.
8. BRACKET MATERIAL: TIN PLATED PHOSPHOR BRONZE.
9. CONNECTOR OUTLINE.
10. COPLANARITY ON ALL CONTACT TAILS AND PADS 0.12MM MAXIMUM.

# BATTERY CONNECTORS

## Vertical Mate 2.0mm Pitch 9155-800



### 5 WAY BATTERY CONNECTOR – RIGHT ANGLE 2MM PITCH - WITH BOSS

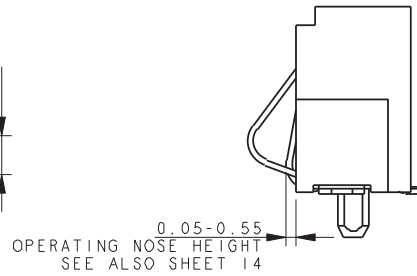
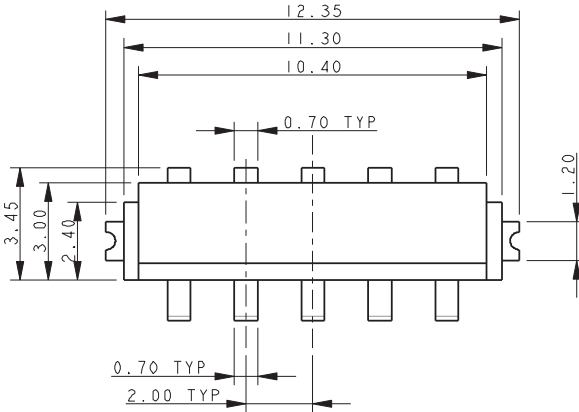

#### DEFLECTED CONTACT

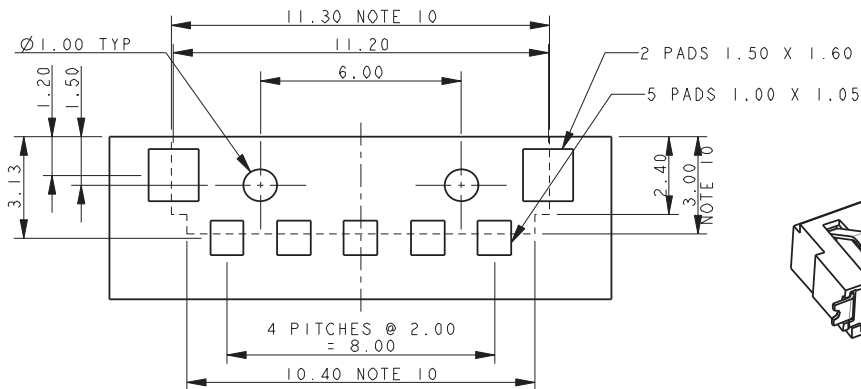
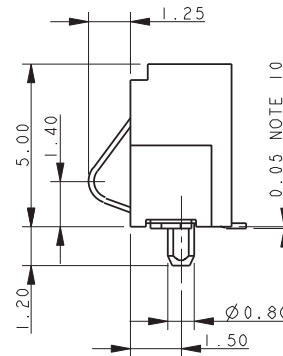
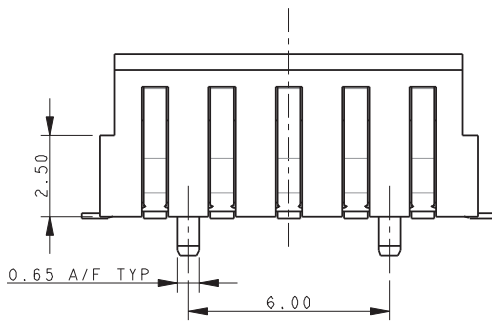

#### SUGGESTED PCB LAYOUT

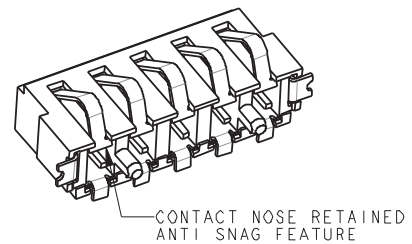

#### NOTES:

1. GENERAL TOLERANCE  $\pm 0.20$  UNLESS STATED.
2. FOR FULL PRODUCT DETAILS REFER TO SPECIFICATION 201-01-2014.  
FOR APPLICATION DATA REFER TO SPECIFICATION 201-01-205.
3. FOR MATING PAD DETAILS REFER TO PAGE 44.
4. FOR PACKING DETAILS REFER TO PAGE 43
5. INSULATION MATERIAL: GLASS FILLED NYLON 46, UL94 V-0, COLOR BLACK.
6. CONTACT MATERIAL: BERYLLIUM COPPER.
7. CONTACT PLATING: SELECTIVE GOLD OVER NICKEL, PURE TIN ON TAILS.
8. BRACKET MATERIAL: TIN PLATED PHOSPHOR BRONZE.
9. CONNECTOR OUTLINE.
10. COPLANARITY ON ALL CONTACT TAILS AND PADS 0.12MM MAXIMUM.



The Important Information/Disclaimer is incorporated in the catalog where these specifications came from or available online at [www.kyocera-avx.com/disclaimer/](http://www.kyocera-avx.com/disclaimer/) by reference and should be reviewed in full before placing any order.

092921

# BATTERY CONNECTORS

## Vertical Mate 2.0mm Pitch 9155-800



### 6 WAY BATTERY CONNECTOR – RIGHT ANGLE 2MM PITCH - WITH BOSS

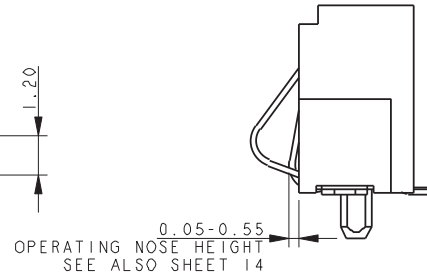
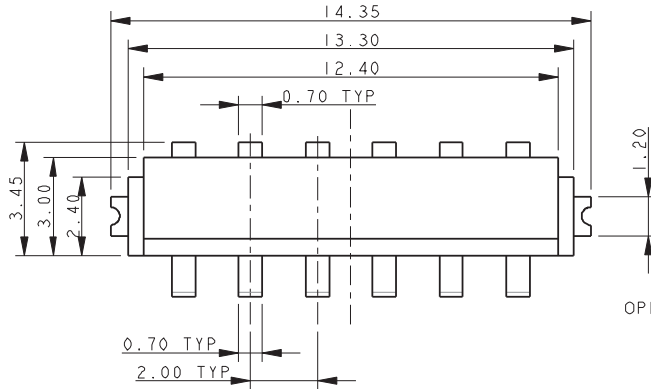

#### DEFLECTED CONTACT

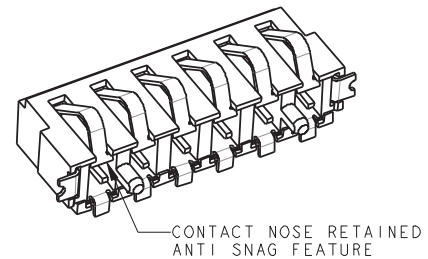
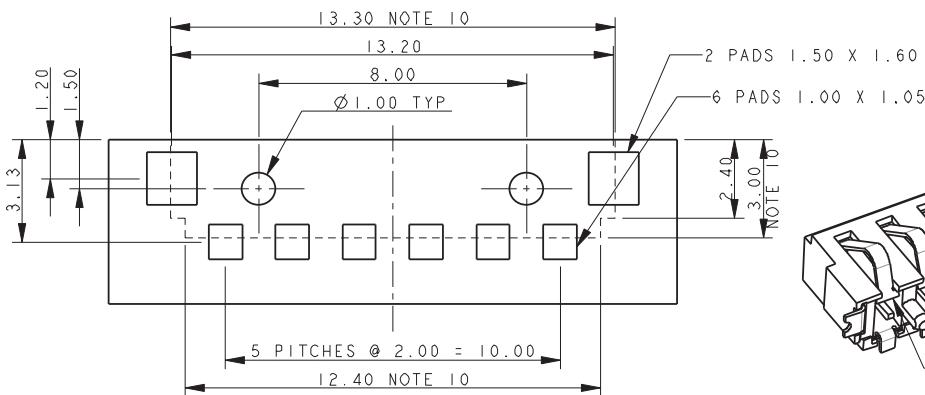
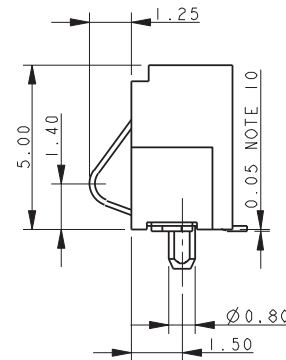
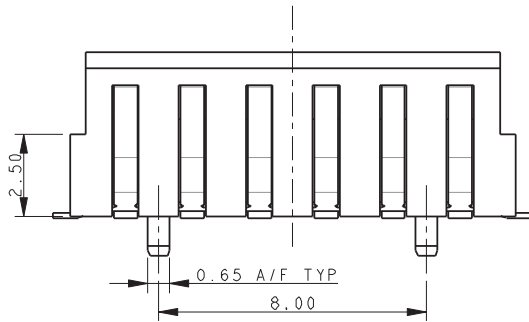

#### SUGGESTED PCB LAYOUT

#### NOTES:

1. GENERAL TOLERANCE  $\pm 0.20$  UNLESS STATED.
2. FOR FULL PRODUCT DETAILS REFER TO SPECIFICATION 201-01-2014.  
FOR APPLICATION DATA REFER TO SPECIFICATION 201-01-205.
3. FOR MATING PAD DETAILS REFER TO PAGE 44.
4. FOR PACKING DETAILS REFER TO PAGE 43
5. INSULATION MATERIAL: GLASS FILLED NYLON 46, UL94 V-O, COLOR BLACK.
6. CONTACT MATERIAL: BERYLLIUM COPPER.
7. CONTACT PLATING: SELECTIVE GOLD OVER NICKEL, PURE TIN ON TAILS.
8. BRACKET MATERIAL: TIN PLATED PHOSPHOR BRONZE.
9. CONNECTOR OUTLINE.
10. COPLANARITY ON ALL CONTACT TAILS AND PADS 0.12MM MAXIMUM.

# BATTERY CONNECTORS

## Vertical Mate 2.0mm Pitch 9155-800

### PACKING DETAILS

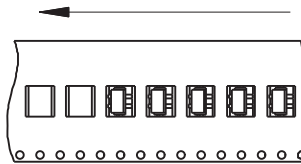
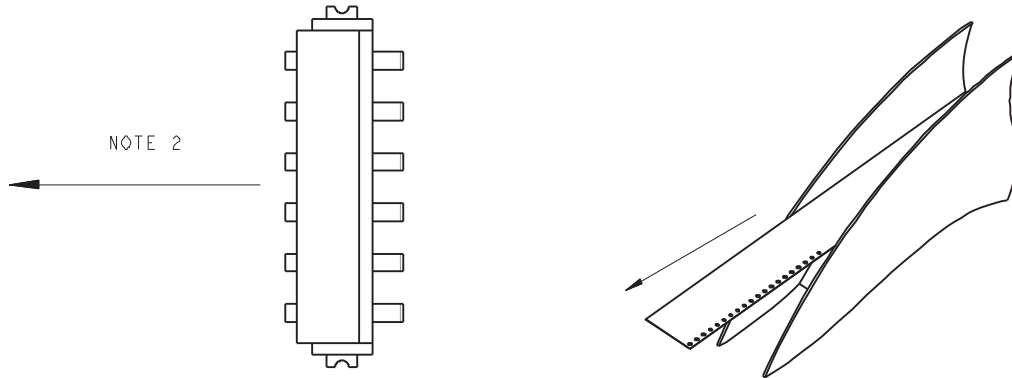

<b>No of Ways</b>	<b>2</b>
REEL QTY	100 without Boss
TAPE WIDTH	24mm
POCKET PITCH	8mm

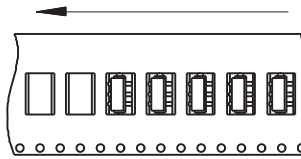

<b>No of Ways</b>	<b>3</b>
REEL QTY	100 without Boss
TAPE WIDTH	24mm
POCKET PITCH	8mm

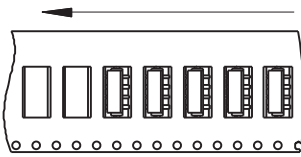

<b>No of Ways</b>	<b>4</b>
REEL QTY	100 without Boss
TAPE WIDTH	24mm
POCKET PITCH	8mm

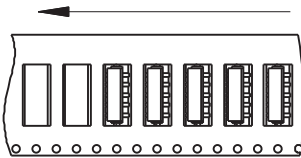

<b>No of Ways</b>	<b>5</b>
REEL QTY	100 without Boss
TAPE WIDTH	24mm
POCKET PITCH	8mm

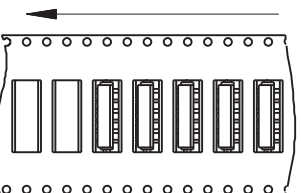

<b>No of Ways</b>	<b>6</b>
REEL QTY	100 without Boss
TAPE WIDTH	24mm
POCKET PITCH	8mm

**NOTES:**

1. PARTS TO BE PACKED ON 330MM DIAMETER REELS.
2. COMPONENT ORIENTATION SHOWN.

# BATTERY CONNECTORS

## Vertical Mate 2.0mm Pitch 9155-800

### 2MM PITCH RIGHT ANGLE – MATING PADS

#### 2 WAY – MATING PADS

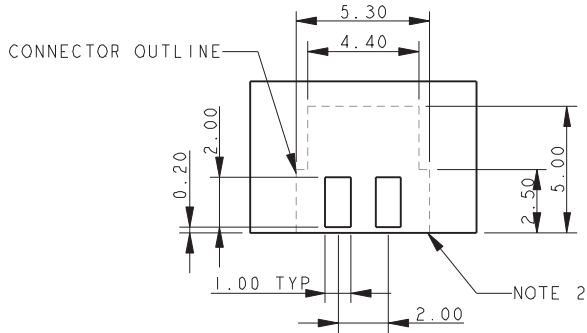

#### 3 WAY – MATING PADS

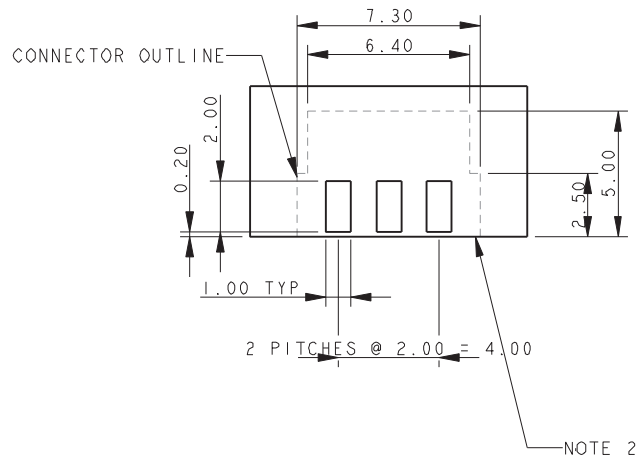

#### 4 WAY – MATING PADS

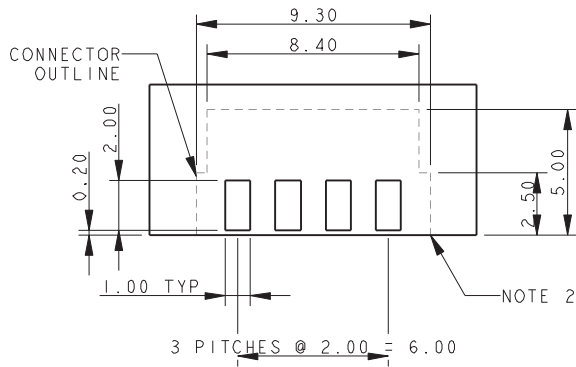

#### 5 WAY – MATING PADS

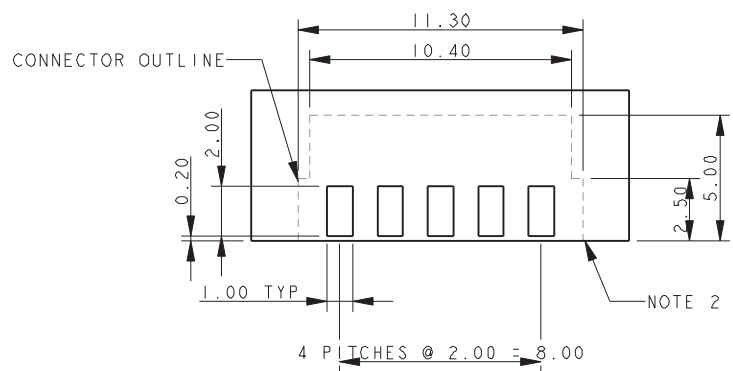

#### 6 WAY – MATING PADS

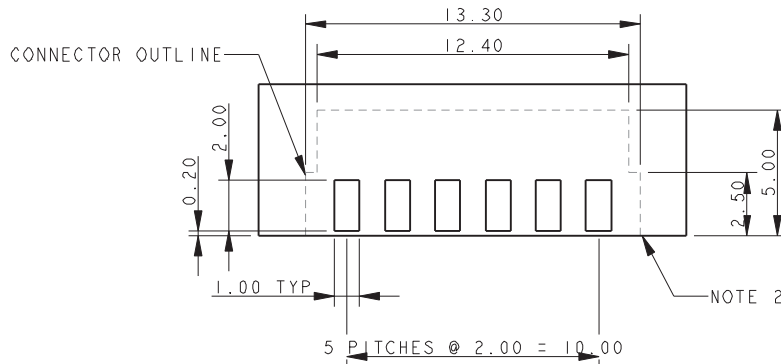

#### NOTES:

1. SUGGESTED MATING PADS FOR RIGHT ANGLE BATTERY CONNECTOR.
2. TOP SURFACE OF SMT PCB/BASE OF CONNECTOR.
3. PREFERRED PLATING ON PADS, GOLD OVER NICKEL.

# BATTERY CONNECTORS

Vertical Mate 2.0mm Pitch 9155-800

## 2MM PITCH RIGHT ANGLE CONNECTOR

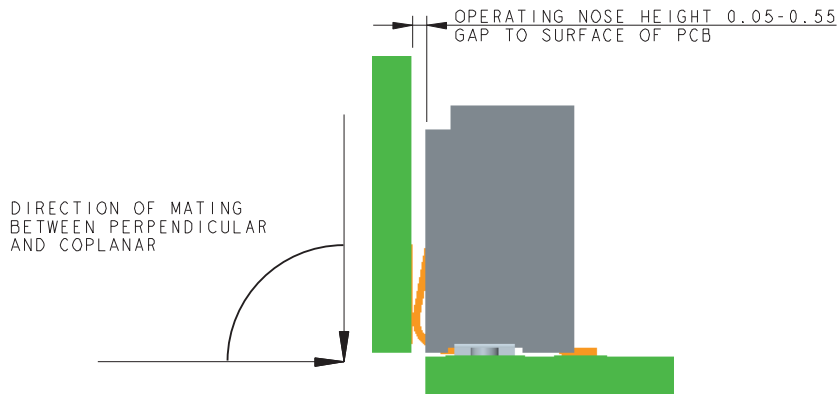
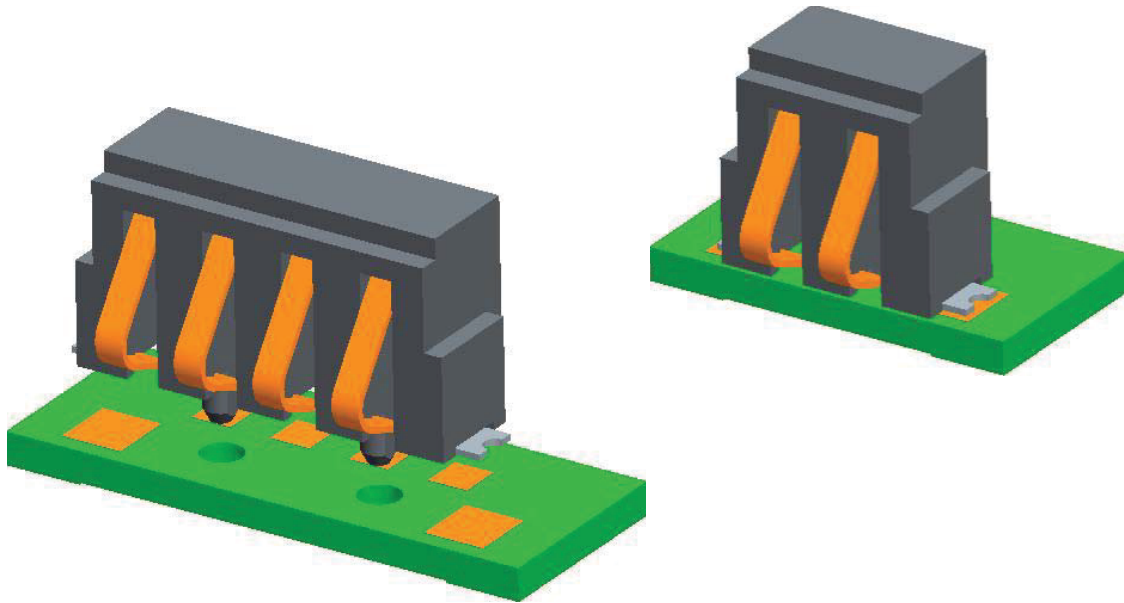

### BOARD TO BOARD/COMPONENT (REFER TO APPLICATION NOTES 201-01-205)

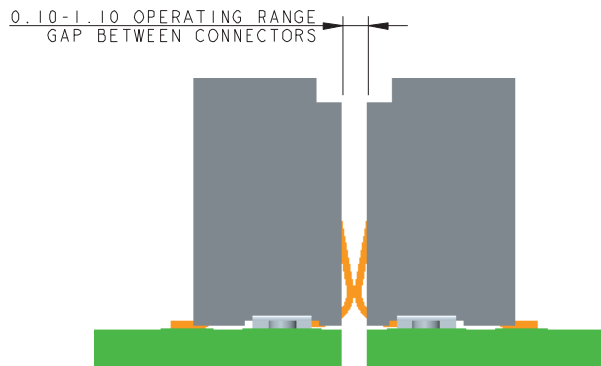

### CONNECTOR TO CONNECTOR (REFER TO APPLICATION NOTES 201-01-205)



# BATTERY CONTACTS

## Single Compression Contact



Designers for ruggedized connectors to meet harsh environments continue to look for new products which will reduce size and cost without jeopardizing performance. The new Ultra-Low Profile (ULP) compression contact from KYOCERA AVX surface mounts to a PCB and provides a reliable compression connection to the mating board, even under extreme shock and vibration applications. With over 20 years of 1-Piece compression contact experience, this innovative contact offers full connector performance functionality at the individual contact level. Thus, allowing single contacts to be placed in any location or position on a PCB.

The high force beryllium copper contact is gold plated to maximize reliability and signal integrity. The current offering has two contacts with nominal heights of 1.0mm and 1.5mm. Add in the "Z" axis tolerance range and the compressed height covers 0.75mm up to 1.75mm. The contacts are supplied in tape and reel for easy SMT placement.

### APPLICATIONS

- Industrial/Ruggedized handheld or portable devices
- BTB connection for any traditional power or signal application
- Ground connections between PCB's or housings

### FEATURES AND BENEFITS

- Reliable gold plated Beryllium Copper contacts for high cycle life and signal integrity up to 1000 cycles
- Tape and reel packaged for automated SMT placement
- Sweeping beam design for pluggable/module applications
- Three gold plating options to match end product environmental or expected life requirements

### ELECTRICAL

- Current Rating: 3 Amps
- Voltage Rating: Based on placement distance

### ENVIRONMENTAL

- Operating Temperature: -40°C to +125°C

### MECHANICAL

- Contact Material: Beryllium Copper
- Contact Plating: Gold over Nickel
- Durability: 50, 500 and 1000 cycles

### HOW TO ORDER

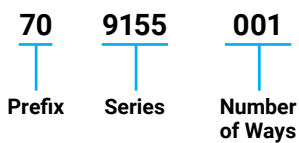

**61X**

Contact Description

Code	Nominal Operating Height	Contact Operating Height Range
610	1.00mm	0.75mm to 1.25mm
615	1.50mm	1.25mm to 1.75mm

**61X**

Contact Description

Code	Gold Thickness	Description	Availability
004	0.1µm	Nickel under Plate, Gold on Nose Tin on Remainder	Standard
006	0.4µm	Nickel under Plate, Gold on Nose Tin on Remainder	Special Order
008	0.8µm	Nickel under Plate, Gold on Nose Tin on Remainder	Special Order

Certification: UL File #E90723



# BATTERY CONTACTS

## Single Compression Contact

70-9155-001-610-006  
NOMINAL WORKING HEIGHT 1.00MM

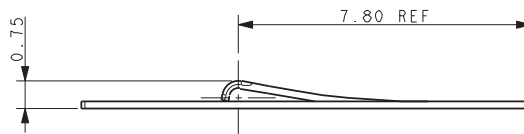
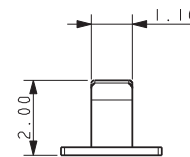
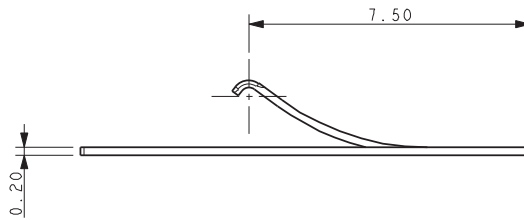
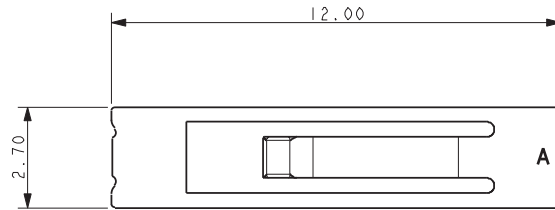

**FULLY DEFLECTED CONTACT**

### SUGGESTED MATING PCB LAYOUT

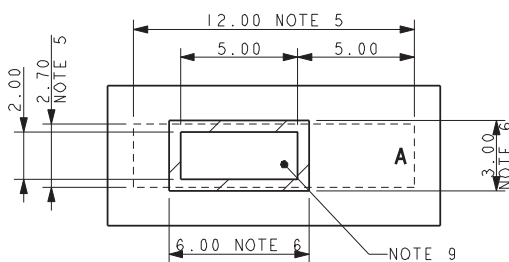

#### NOTES:

1. 9155 LOW PROFILE CONTACT, WORKING HEIGHT 0.75MM TO 1.25MM.
2. FOR FULL DETAILS REFER TO PRODUCT SPECIFICATION 201-01-153 AND APPLICATIONS NOTES 201-01-154.
3. MATERIAL: COPPER ALLOY 0.2MM THICK.
4. PLATING: NICKEL ALL OVER WITH GOLD ON CONTACT NOSE AND TIN ON THE REMAINDER. PARTS TO BE PACKED IN TAPE AND REEL. QTY PER REEL 3000.
5. OUTLINE OF CONNECTOR, ORIENTATION END "A".
6. AREA TO BE KEPT FREE OF SOLDER RESIST, FURTHER INFORMATION IN APPLICATION NOTES.
7. AREA BETWEEN PADS TO BE KEPT CLEAR OF TRACKS AND COMPONENTS.
8. SMT PADS PLATED TIN.
9. MATING PAD PLATED GOLD OVER NICKEL.

### SUGGESTED SMT PCB LAYOUT

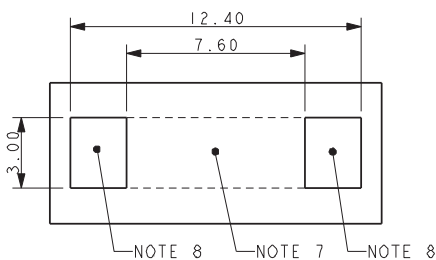

### PACKING DETAILS

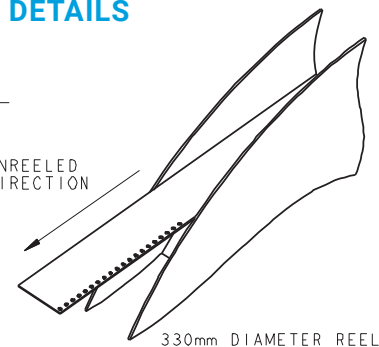
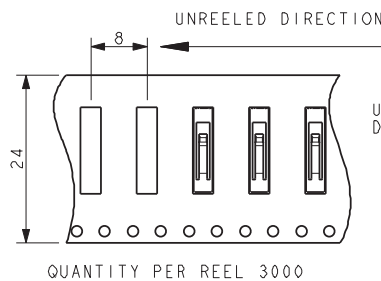

330mm DIAMETER REEL

# BATTERY CONTACTS

## Single Compression Contact

70-9155-001-610-006  
 NOMINAL WORKING HEIGHT 1.50MM

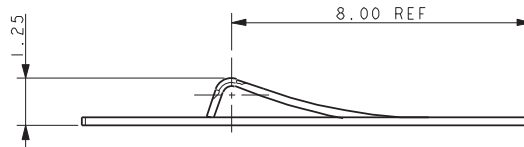
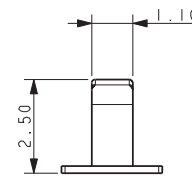
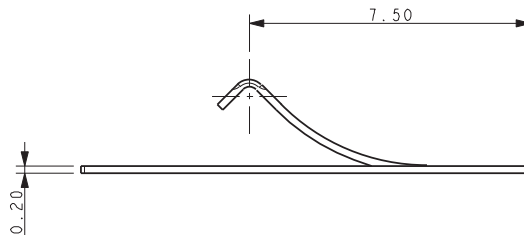
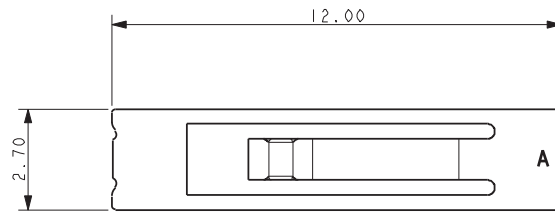

**FULLY DEFLECTED CONTACT**

### SUGGESTED MATING PCB LAYOUT

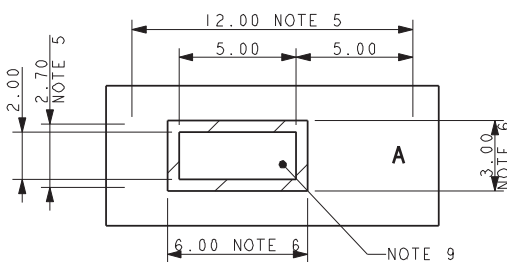

#### NOTES:

1. 9155 LOW PROFILE CONTACT, WORKING HEIGHT 0.75MM TO 1.25MM.
2. FOR FULL DETAILS REFER TO PRODUCT SPECIFICATION 201-01-153 AND APPLICATIONS NOTES 201-01-154.
3. MATERIAL: COPPER ALLOY 0.2MM THICK.
4. PLATING: NICKEL ALL OVER WITH GOLD ON CONTACT NOSE AND TIN ON THE REMAINDER. PARTS TO BE PACKED IN TAPE AND REEL. QTY PER REEL 3000.
5. OUTLINE OF CONNECTOR, ORIENTATION END "A".
6. AREA TO BE KEPT FREE OF SOLDER RESIST, FURTHER INFORMATION IN APPLICATION NOTES.
7. AREA BETWEEN PADS TO BE KEPT CLEAR OF TRACKS AND COMPONENTS.
8. SMT PADS PLATED TIN.
9. MATING PAD PLATED GOLD OVER NICKEL.

### SUGGESTED SMT PCB LAYOUT

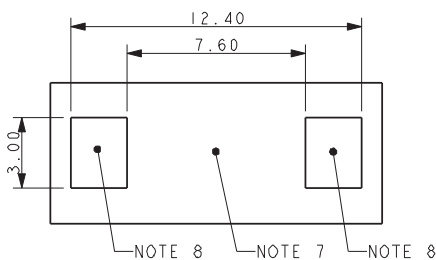

### PACKING DETAILS

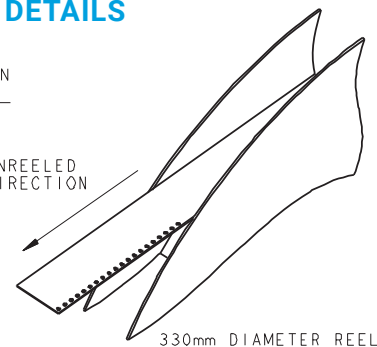
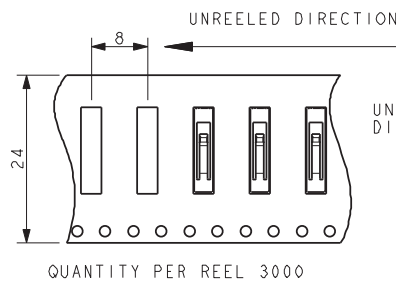

# I/O CONNECTORS

## Standard I/O, 15 Position, XX-9157



The 9157 series was specifically designed for portable equipment.

KYOCERA AVX now offers this two-part system as a standard product. The fixed SMT socket is designed to be housed within the confined dimensional constraints of the portable device.

The plug/cover connector has sprung contacts and is designed for termination to accessory equipment. The connector is designed to house fifteen signal contacts on a 1mm pitch rated at 1.5A. There is the option to include a switching RF coax.

A cradle SMT plug connector for docking applications is also available as standard and has the option of including a SMT RF coax.

Whatever your requirements, the 9157 series can also be customized to suit your application.

### APPLICATIONS

- Mobile Phones
- PDA
- Medical
- Docking/Charging for any portable device

### FEATURES AND BENEFITS

- Patented 20° angled face on the socket gives self-cleaning face when mated with plug.
- Metal Latching area integral to socket which saves PCB real estate.
- Integral to socket is a mechanical 50Ω switching coax for SMT termination.
- Single sprung plug contact design gives ten thousand mating cycles and cleaning/wiping action.
- Customer has option to terminate own RF coax using KYOCERA AVX custom tooling: 06-9157-7116-01-000.
- SMT plug has unique location pyramids that give positive alignment to portable device, and assist blind mating.
- RoHS Compliant.

### ELECTRICAL

- Current Rating: 1.5 Amps / Contact
- Voltage Rating: 125 VAC

### ENVIRONMENTAL

- Operating Temperature: -55°C to +125°C

### MECHANICAL

- Insulator Material: Glass-Filled Nylon 46; UL94 V-0
- Contact Material: Beryllium Copper (plug)  
Phosphor Bronze (socket)
- Plating: Gold over Nickel
- Durability: 10,000 Cycles

### HOW TO ORDER

#### Plug Options – Example

<b>XX</b>	<b>9157</b>	<b>015</b>	<b>00X</b>
Prefix	Series	No of Ways	RF Coax Option
10 = Plug 58 = Special		15 = 015	000 = No RF Coax 001 = With RF Coax

#### Contact Type

Code	Type	Contact Plating
006	Wire	Nickel, Gold Nose, Pure Tin Tail
007	SMT	Nickel, Gold Nose, Pure Tin Tail

#### PACKING DETAILS

Type	Size	Description
Wire	580	Tube
SMT	300	Tape & Reel

#### Socket Options – Example

<b>20</b>	<b>9157</b>	<b>015</b>	<b>00X</b>	<b>006</b>
Prefix	Series	No of Ways	RF Coax Option	Contact Type
20 = Socket 58 = Special		15 = 015	000 = No RF Coax 001 = With RF Coax	006 = SMT

#### Cover Options – Example

<b>30</b>	<b>9157</b>	<b>9700</b>	<b>00</b>	<b>0XX</b>
Prefix	Series	Cover Kit Press and Screw Assembly	Standard	Grommet Variation

Code	Description	Qty
9700	Cover Side	1
	Cover Body	1
	Latch Button	2
	Metal Latch	2
	Fixing Screw	2

Code	Description	Qty
000	No Grommet	NA
035	3.5mm Grommet	1
050	5.0mm Grommet	1

#### PACKING DETAILS

Kit to be ordered in multiples of 580

Item	Packing	Parts packed in bags of
Cover Side	Pack Parts in Bags Qty as Column 3	580
Cover Body		580
Latch Button		1160
Metal Latch		1160
Grommet		580
Fixing Screw		1160 When Required



Patent:  
2276285  
5540599



The Important Information/Disclaimer is incorporated in the catalog where these specifications came from or available online at [www.kyocera-avx.com/disclaimer/](http://www.kyocera-avx.com/disclaimer/) by reference and should be reviewed in full before placing any order.

# I/O CONNECTORS

## Standard I/O, 15 Position, XX-9157

### 9157 PLUG WIRE WITHOUT COAX

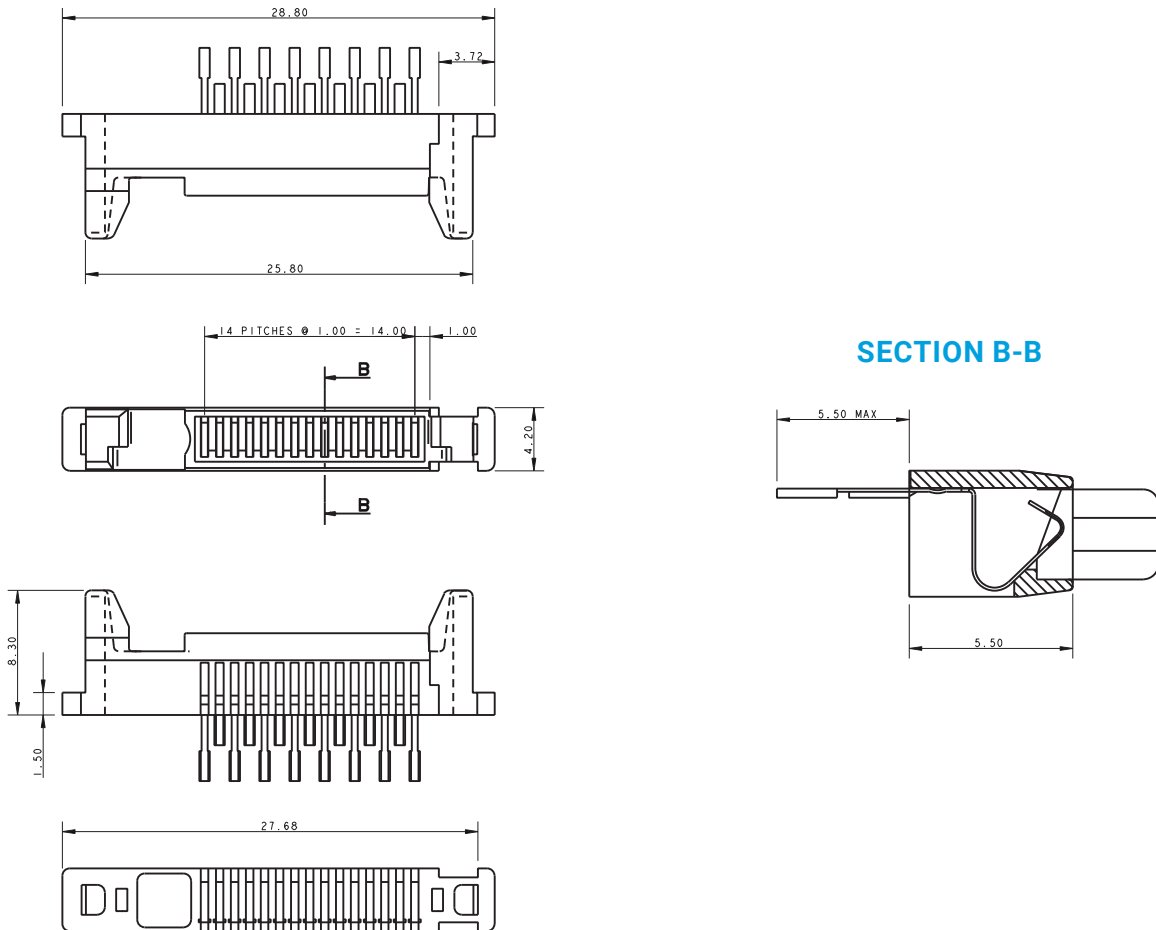

### PACKING DETAILS

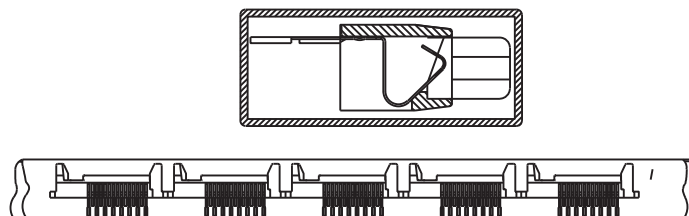

#### NOTES:

1. ALL DIMENSIONS SHOWN ARE REFERENCE DIMENSIONS.
2. PACKED IN TUBES, 20 PIECES PER TUBE.
3. MINIMUM ORDER QUANTITY 580 PIECES, THEREAFTER TO BE SUPPLIED IN MULTIPLES OF 580.
4. FOR FULL PRODUCT INFORMATION REFER TO ELCO SPECIFICATION 201-01-079.

# I/O CONNECTORS

## Standard I/O, 15 Position, XX-9157

### 9157 PLUG SMT WITHOUT COAX

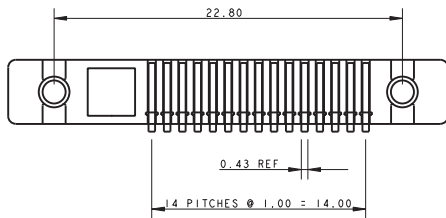
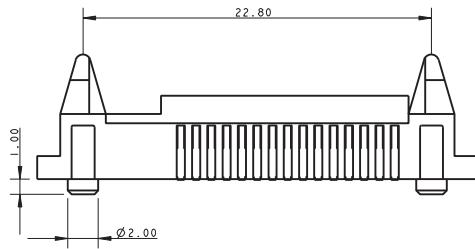
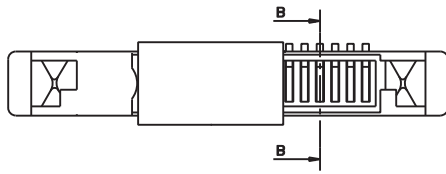
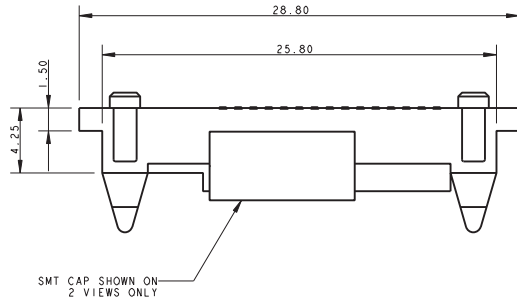

### SECTION B-B

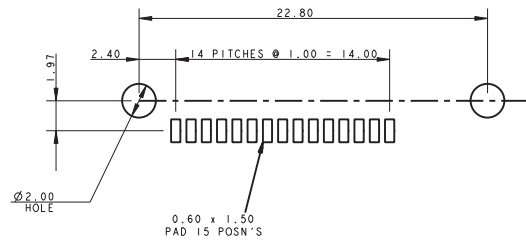
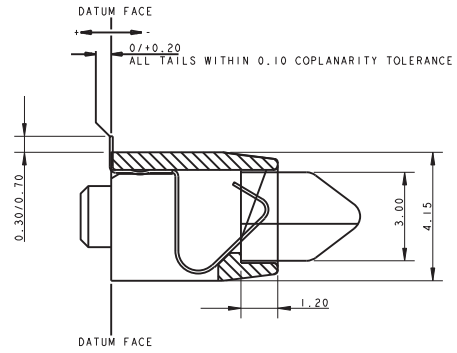

### PACKING DETAILS

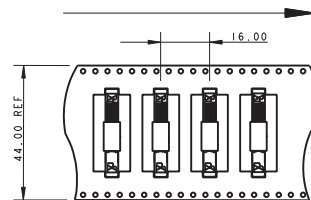
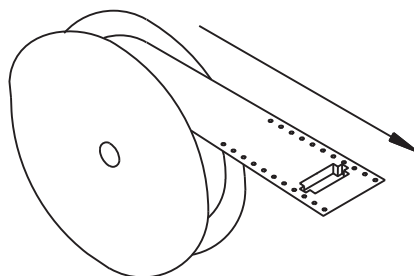

#### NOTES:

1. ALL DIMENSIONS SHOWN ARE REFERENCE DIMENSIONS.
2. PACKED IN TAPE AND REEL, 300 PIECES PER REEL.
3. FOR FULL PRODUCT INFORMATION REFER TO ELCO SPECIFICATION 201-01-079.

# I/O CONNECTORS

## Standard I/O, 15 Position, XX-9157

### 9157 PLUG WIRE WITH COAX

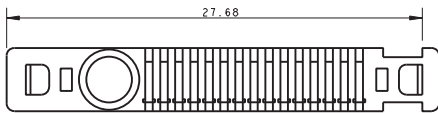
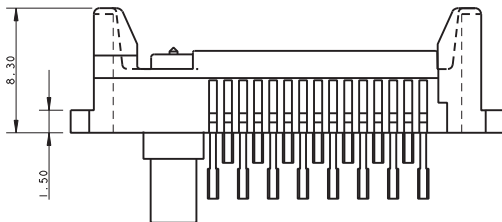
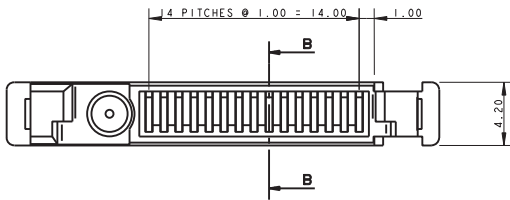
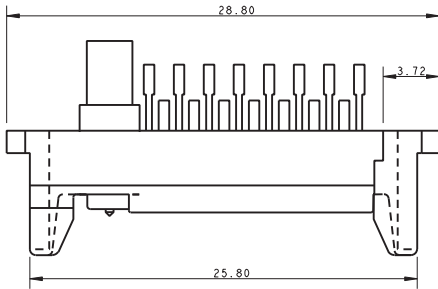

### SECTION B-B

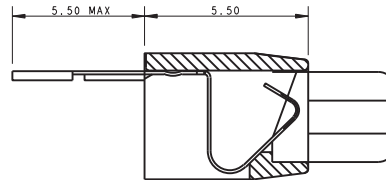

### CRIMPING DETAILS

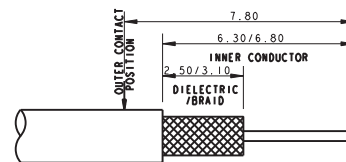
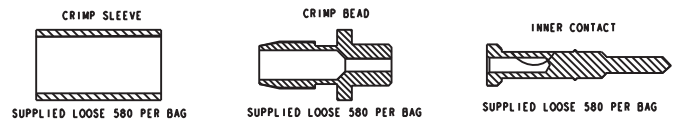

### PACKING DETAILS

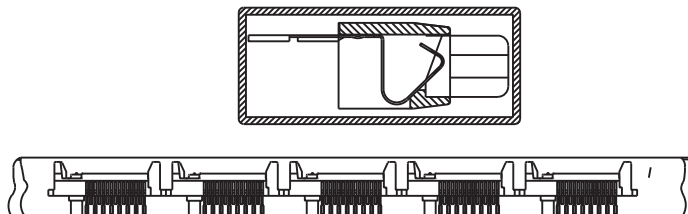

#### NOTES:

1. TOOL TO CRIP BARREL ELECO PART NUMBER 06-9157-7117-01-000.
2. ALL DIMENSIONS SHOWN ARE REFERENCE DIMENSIONS.
3. PACKED IN TUBES, 20 PIECES PER TUBE.
4. MINIMUM ORDER QUANTITY 580 PIECES, THEREAFTER TO BE SUPPLIED IN MULTIPLES OF 580.
5. FOR FULL PRODUCT INFORMATION REFER TO ELCO SPECIFICATION 201-01-079.

# I/O CONNECTORS

## Standard I/O, 15 Position, XX-9157

### 9157 PLUG SMT WITHOUT COAX

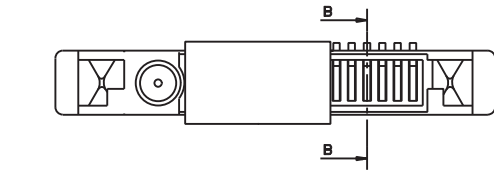
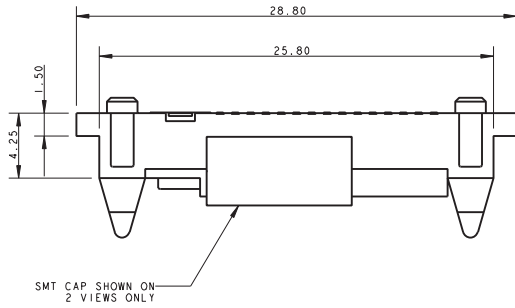

### SECTION B-B

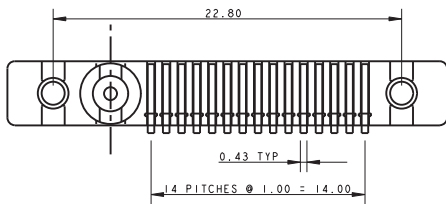
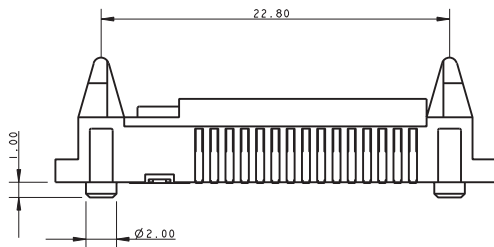
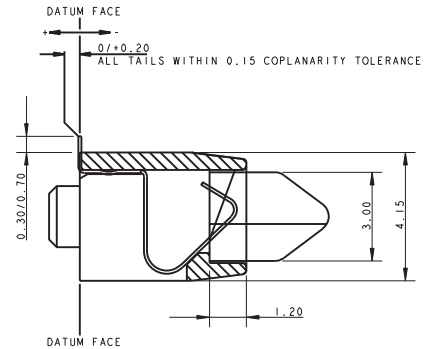

### PACKING DETAILS

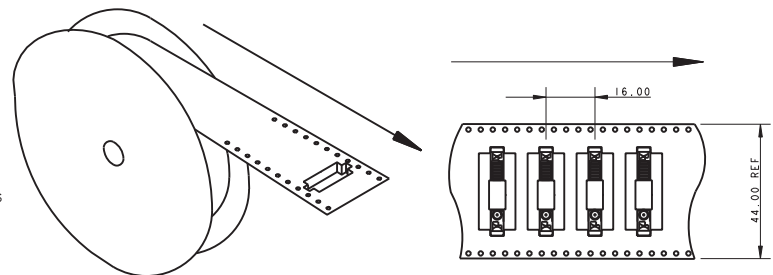

### PCB LAYOUT

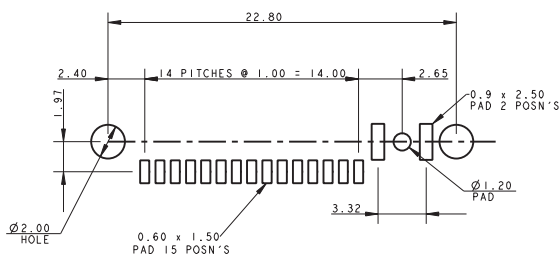

#### NOTES:

1. ALL DIMENSIONS SHOWN ARE REFERENCE DIMENSIONS UNLESS TOLERANCED.
2. PACKED IN TAPE AND REEL, 300 PIECES PER REEL.
3. FOR FULL PRODUCT INFORMATION REFER TO ELCO SPECIFICATION 201-01-079.



# I/O CONNECTORS

## Standard I/O, 15 Position, XX-9157

### 9157 SOCKET WITHOUT COAX

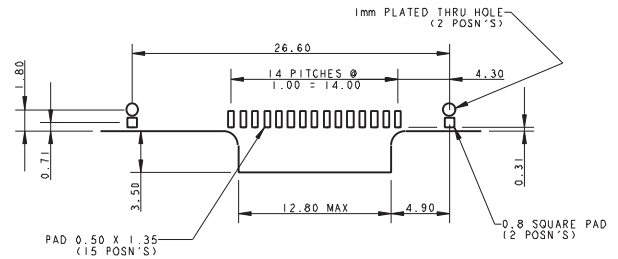
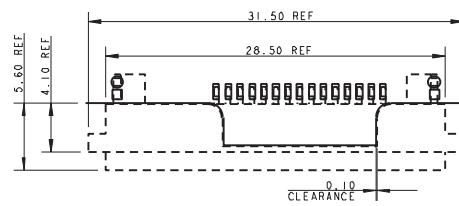
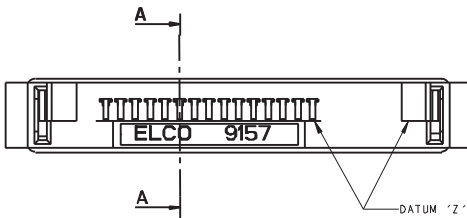
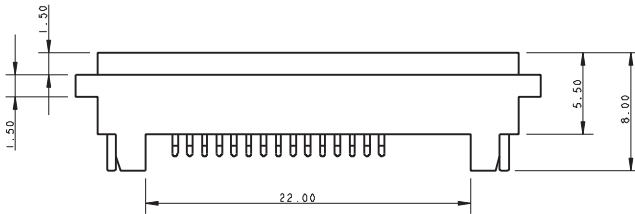
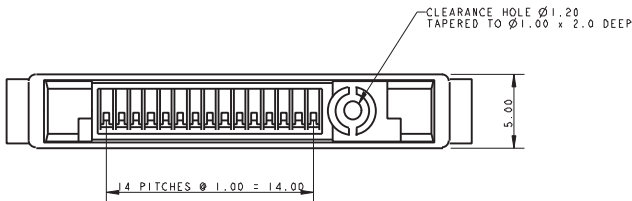
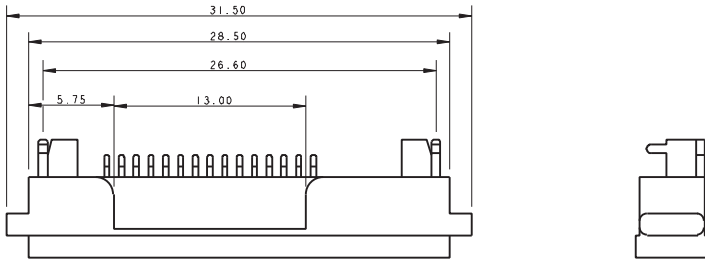

### RECOMMENDED PCB LAYOUT

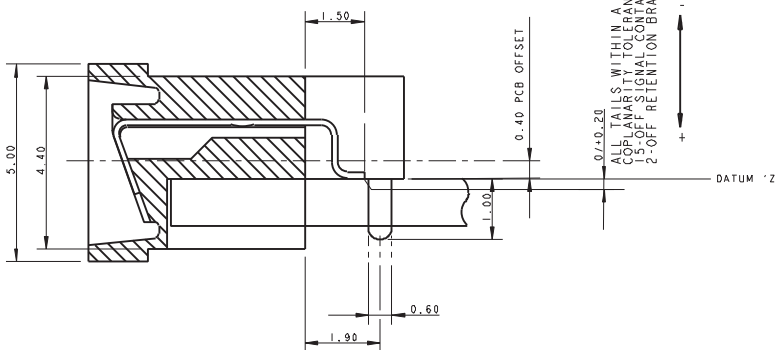

### SECTION A-A

ALL TAILS WITHIN A 0.10 COPLANARITY TOLERANCE  
COPLANARITY TOLERANCE APPLIES TO :-  
2-OFF RETENTION BRACKETS.

#### NOTES:

1. ALL DIMENSIONS SHOWN ARE REFERENCE DIMENSIONS UNLESS TOLERANCED.
2. FOR FULL INFORMATION REFER TO ELCO SPECIFICATION 201-01-079.

# I/O CONNECTORS

## Standard I/O, 15 Position, XX-9157

### 9157 SOCKET WITH COAX

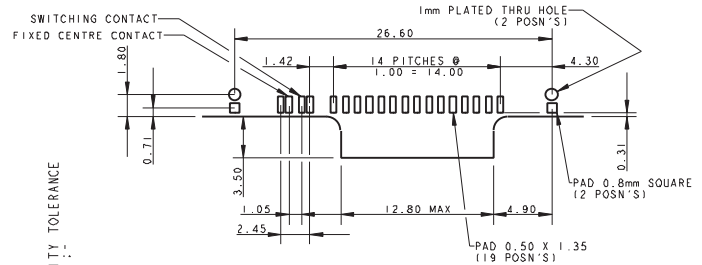
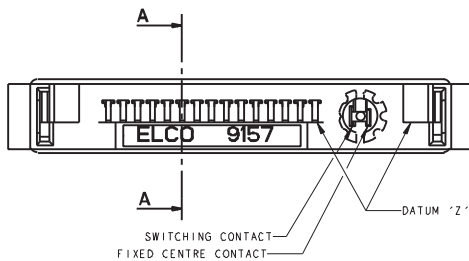
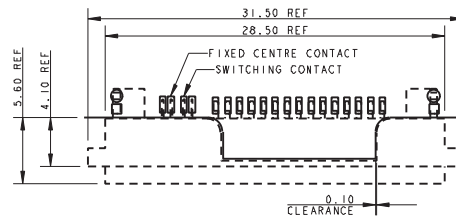
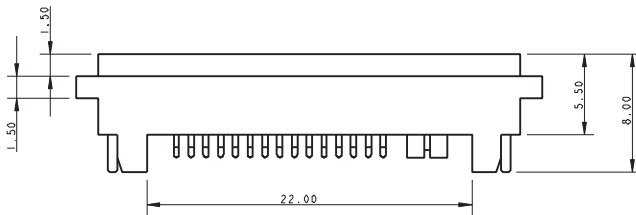
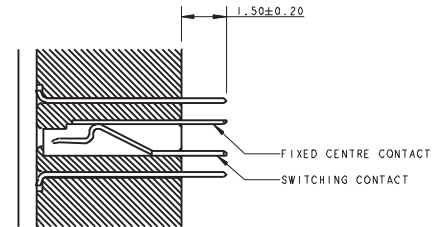
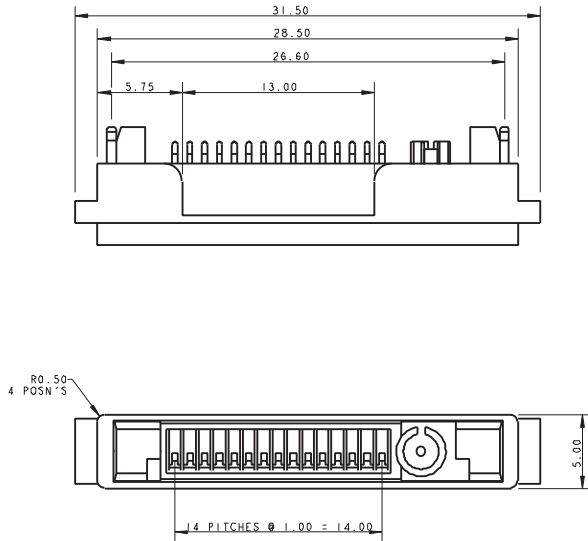

### RECOMMENDED PCB LAYOUT

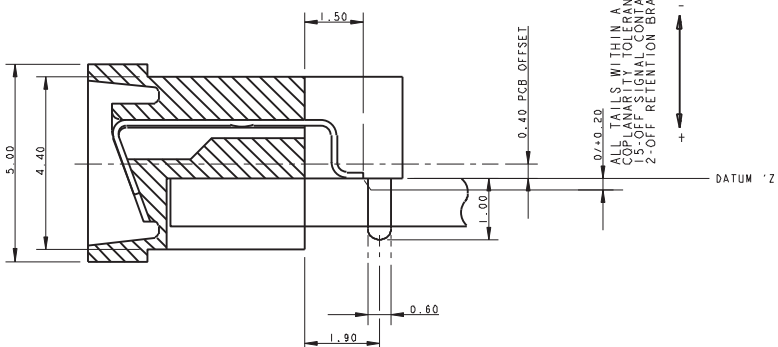

### SECTION A-A

#### NOTES:

1. ALL DIMENSIONS SHOWN ARE REFERENCE DIMENSIONS UNLESS TOLERANCED.
2. FOR FULL INFORMATION REFER TO ELCO SPECIFICATION 201-01-079.

# I/O CONNECTORS

Standard I/O, 15 Position, XX-9157

## 30-9157-9700-00-XXX PRESS AND SCREW VERSION

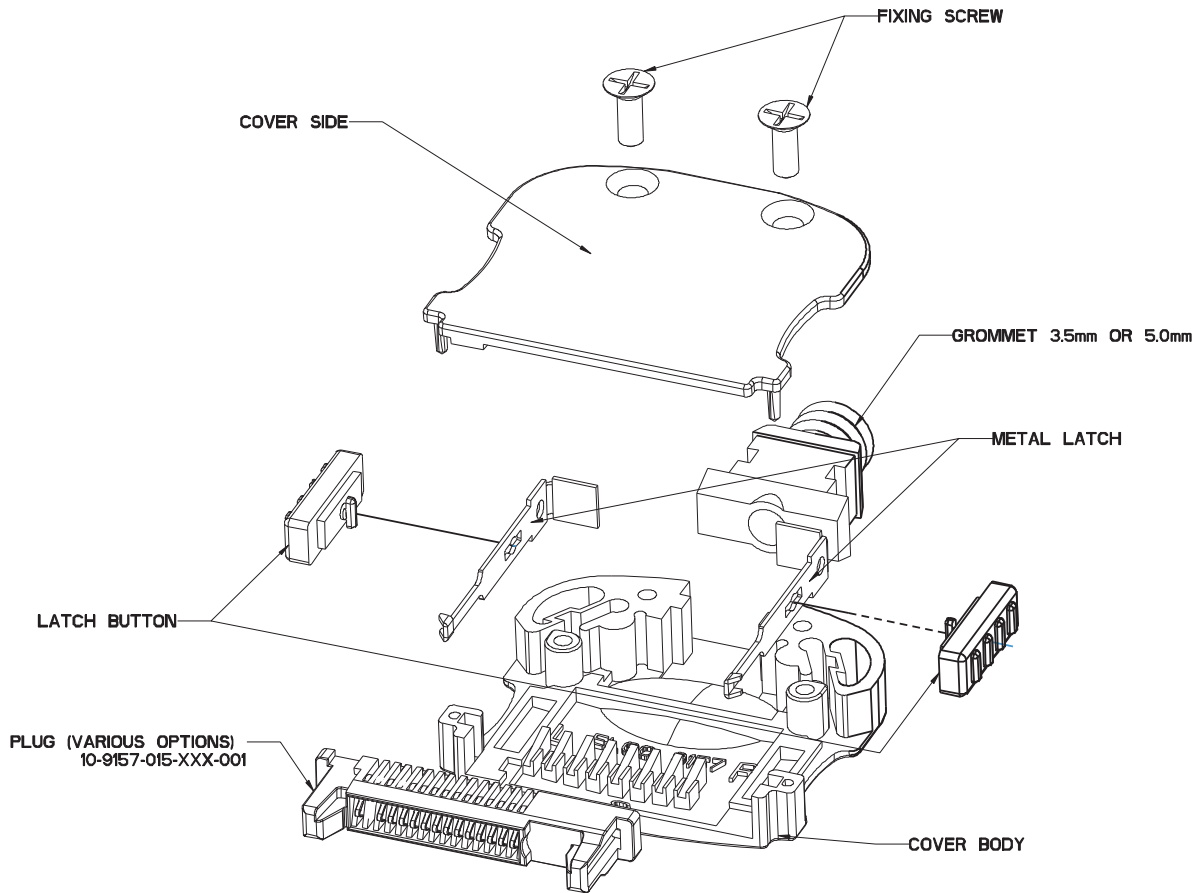

### COVER KIT SHOWN FULL ASSEMBLED WITH PLUG ASSEMBLY 10-9157-015-XXX-001

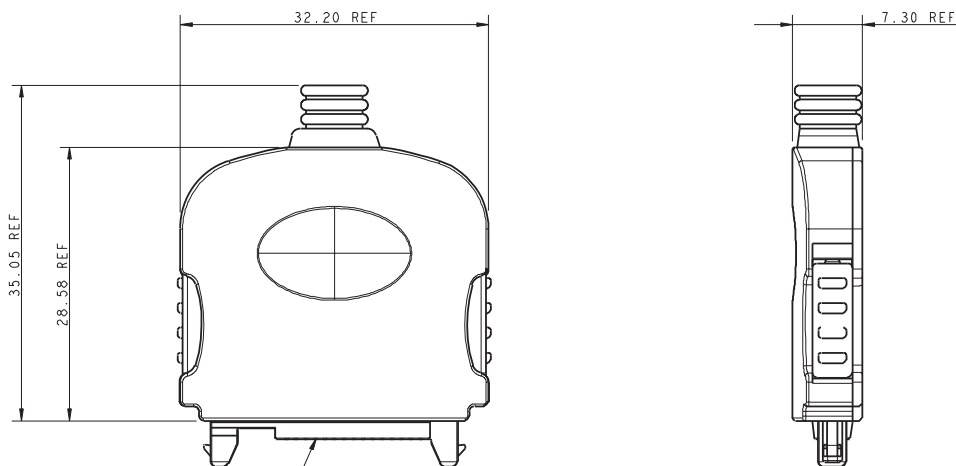

PLUG 10-9157-015-XXX-001

NOTES:  
3 FOR FULL PRODUCT INFORMATION REFER TO  
ELCO SPECIFICATION 201-01-079.

# I/O CONNECTORS

## Standard I/O, 19 Position, XX-9157



Based on our standard 15 way 9157 I/O family, KYOCERA AVX has now released a family 19 way devices. This range includes a SMT 90 degree plug, a wire socket version that is used with the standard 9157 cover and a SMT socket for charging applications.

Options with the 90 degree SMT socket include the sealing of the connector contacts and the connector to the housing. There is also an option to have an EMLB (early mate, late break) on pins 1 and 19.

To achieve the seal to the device housing, it may be necessary to customize the device housing design.

On the SMT 90 degree version, we also have the capability of an integrated DC jack, enabling both the DC jack and the 19 way cover to be plugged in at the same time.

### APPLICATIONS

- Mobile Phones
- PDA
- Medical
- Docking/Charging for any portable device

### FEATURES AND BENEFITS

- Patented 20° angled face on the socket gives self-cleaning face when mated with plug.
- Metal Latching area integral to socket which saves PCB real estate.
- Integral to socket is a mechanical 50Ω switching coax for SMT termination.
- Single sprung plug contact design gives ten thousand mating cycles and cleaning/wiping action.
- Customer has option to terminate own RF coax using KYOCERA AVX custom tooling: 06-9157-7116-01-000.
- SMT plug has unique location pyramids that give positive alignment to portable device, and assist blind mating.
- RoHS Compliant.

### ELECTRICAL

- Current Rating: 1.5 Amps / Contact
- Voltage Rating: 125 VAC

### ENVIRONMENTAL

- Operating Temperature: -55°C to +125°C

### MECHANICAL

- Insulator Material: Glass-Filled Nylon 46; UL94 V-0
- Contact Material: Beryllium Copper (plug)  
Phosphor Bronze (socket)
- Plating: Gold over Nickel
- Durability: 10,000 Cycles

### AVAILABLE DEVICES

- 10 9157 019 000 006** Plug wire version
- 10 9157 019 000 007** SMT charging version
- 20 9157 019 000 006** 90 degree SMT socket
- 30 9157 97 XX 00 000** Cover options

# I/O CONNECTORS

## Standard I/O, 19 Position, XX-9157

### Plug Wire

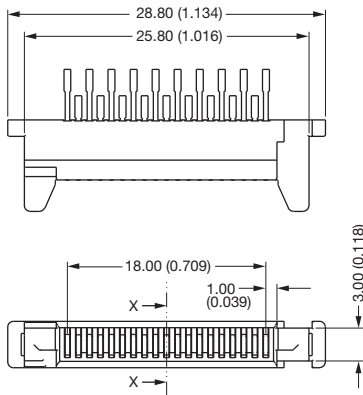

### SMT Plug

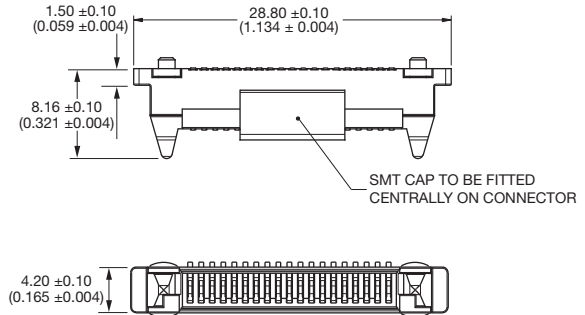

### SMT Socket

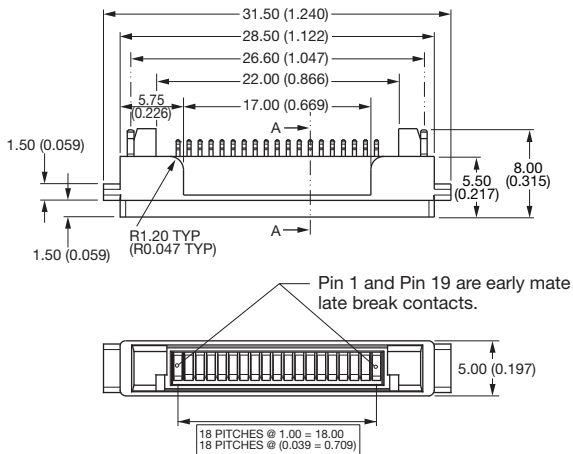

### SMT Plug

#### (Suggested PCB Layout)

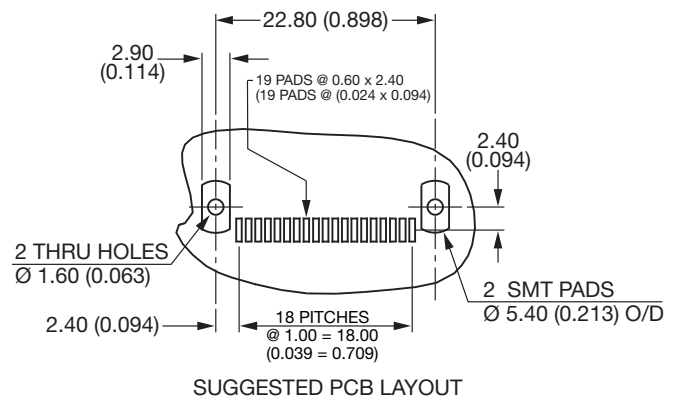

### SMT Socket (Suggested PCB Layout)

# I/O CONNECTORS

## Standard I/O, 19 Position, XX-9157

### Cover Kit

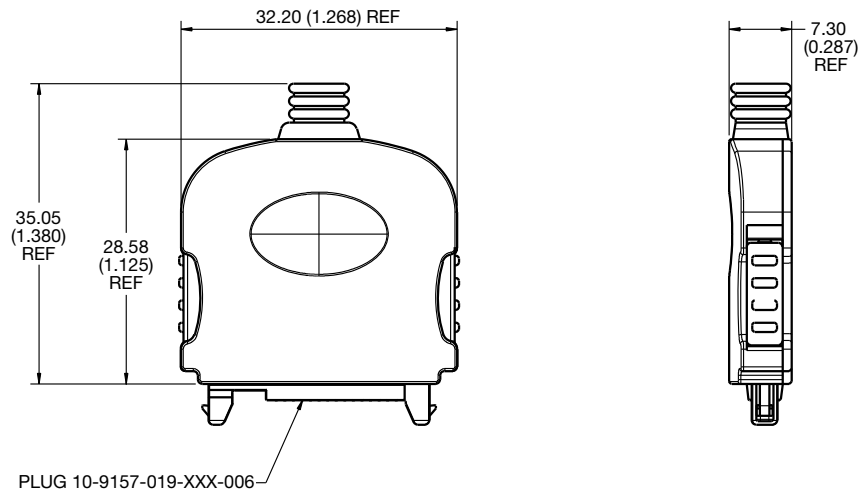

# I/O CONNECTORS

## Reduced Size I/O, 16 Position XX-9257



An I/O interconnect system designed for portable equipment.

KYOCERA AVX offers this plug and socket reduced size system as a standard product. The fixed SMT socket is designed to be mounted on a PCB and housed within a portable device. The plug is designed for cable termination with options of single and double sided contacts and customizing the overmold cover or parts can be supplied as connector only for sub contract termination. The socket connector houses 16 contacts in two rows on 1.25mm pitch with a rating of 1 amp per contact. Both connectors are RoHS compliant.

### APPLICATIONS

- Cellular Phones
- Handheld Devices
- Industrial Modules
- Medical Electronics

### FEATURES AND BENEFITS

- No latching is required due to the click design of the contacts.
- Optional customization of the overmold cover.
- Options of single row (8 way) or dual row (16 way) plug connector.
- Compact size to optimize PCB real estate.
- Metal outer cover provides integrated PCB location and solder tab.
- Positive alignment and orientation of the plug and socket.
- 5K mating cycles and 1 amp rated.

### ELECTRICAL

- Current Rating: 1 Amp / Contact
- Voltage Rating: 125 VAC

### ENVIRONMENTAL

- Operating Temperature: -55°C to +85°C

### MECHANICAL

- Insulator Material: Nylon 46; UL94 V-0
- Contact Material: Beryllium Copper
- Plating: Gold over Nickel
- Durability: 5,000 Cycles

### HOW TO ORDER

#### Plug Options – Example

<b>10</b>	<b>9257</b>	<b>0XX</b>	<b>001</b>	<b>003</b>	<b>PACKING</b> Parts packed in tubes 50 per tube	
Prefix 10 = Plug	Series	No of Ways 008 = 8 Way – One side of the moulding loaded with contacts 016 = 16 Way – Both sides of the moulding loaded with contacts	Contact 001 = Solder Bucket	Plating Option 003 = 0.8µm Selective Gold, Pure Tin Tail		

#### Socket Options – Example

<b>20</b>	<b>9257</b>	<b>016</b>	<b>001</b>	<b>01</b>	<b>3</b>
Prefix 20 = Socket	Series	No of Ways 016 = 16	Contact 001 = SMT Termination	Solder Bracket 001 = Solder Bracket with Location Pegs	Plating Option 3 = 0.8µm Selective Gold, Tin Tail

# I/O CONNECTORS

## Reduced Size I/O, 16 Position XX-9257

### 9157 SOCKET WITH COAX

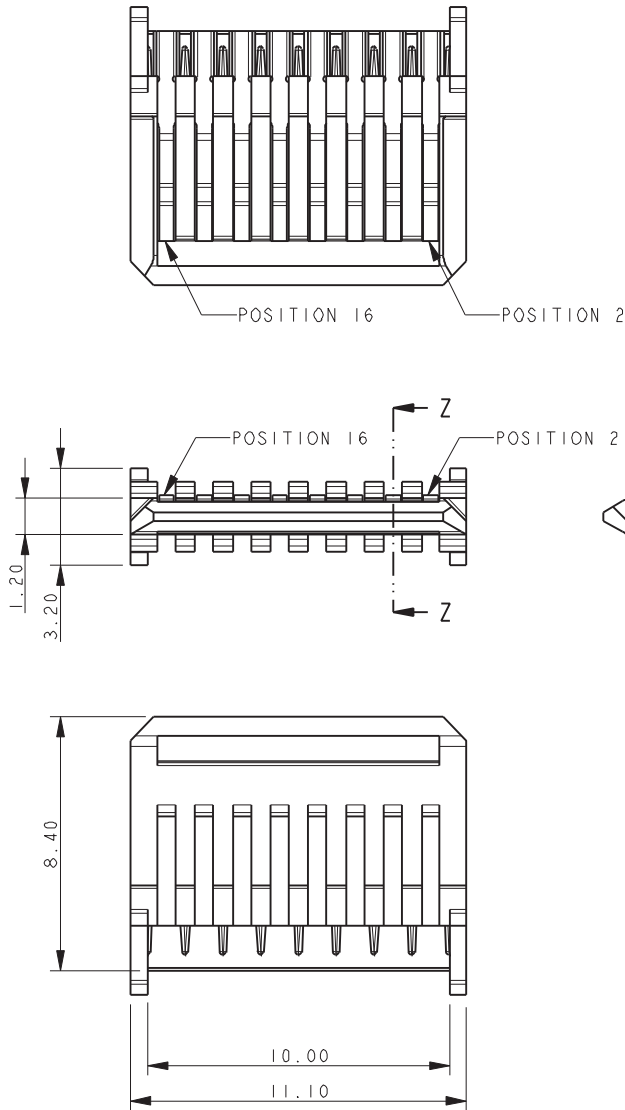

### SECTION Z-Z

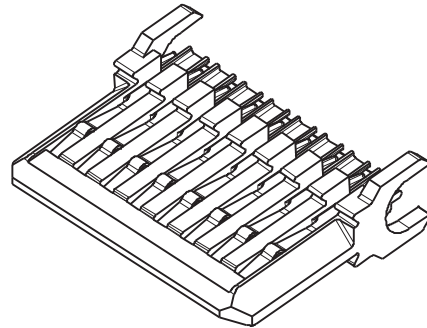

### 50 PARTS PER TUBE

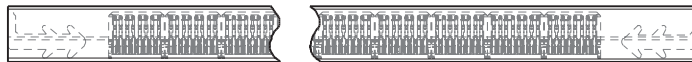

#### NOTES:

1. ALL DIMENSIONS ARE FOR REFERENCE ONLY UNLESS TOLERANCED.
2. FOR FULL PRODUCT SPECIFICATION REFER TO ELCO SPECIFICATION 201-01-089.
3. POSITIONS 2, 4, 6 ... 16 USED, POSITION 1, 3, 5 ... UNUSED.



# I/O CONNECTORS

## Reduced Size I/O, 16 Position XX-9257

### DOUBLE SIDED 16 WAY I/O PLUG CONNECTOR

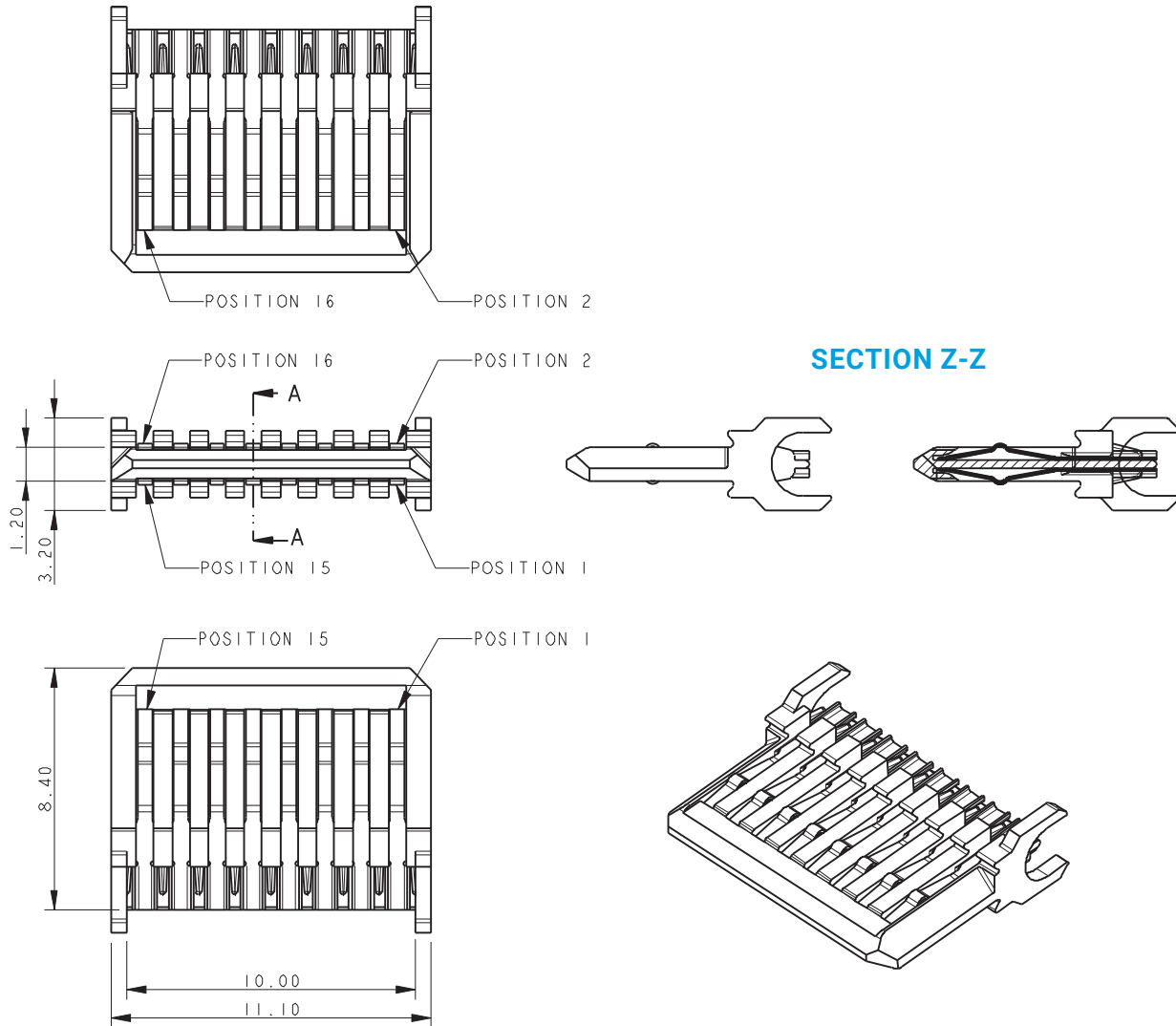

### 50 PARTS PER TUBE



#### NOTES:

1. ALL DIMENSIONS ARE FOR REFERENCE ONLY UNLESS TOLERANCED.
2. FOR FULL PRODUCT SPECIFICATION REFER TO ELCO SPECIFICATION 201-01-089.
3. POSITIONS 2, 4, 6 ... 16 USED, POSITION 1, 3, 5 ... UNUSED.

# I/O CONNECTORS

## Reduced Size I/O, 16 Position XX-9257

### SUGGESTED OVERMOULDING FOR PLUG CONNECTOR (16 WAY – STANDARD STYLE)

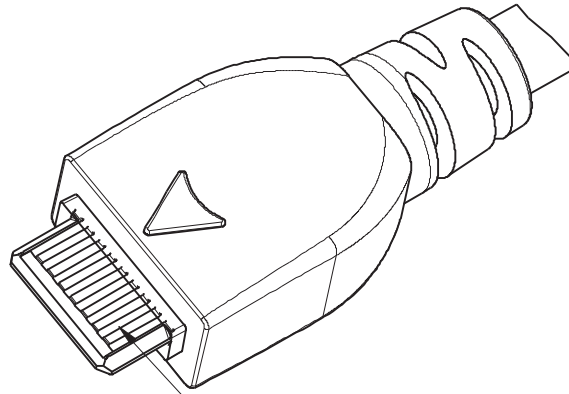
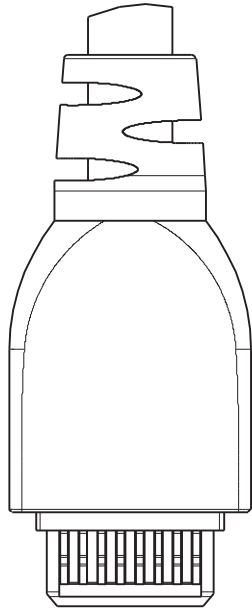

FACIA AREA DESIGNED TO ALLOW FOR SOCKET CONNECTOR TO BE RECESSED IN CASING

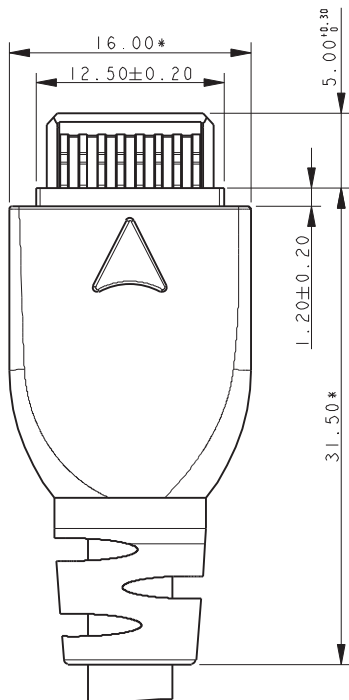
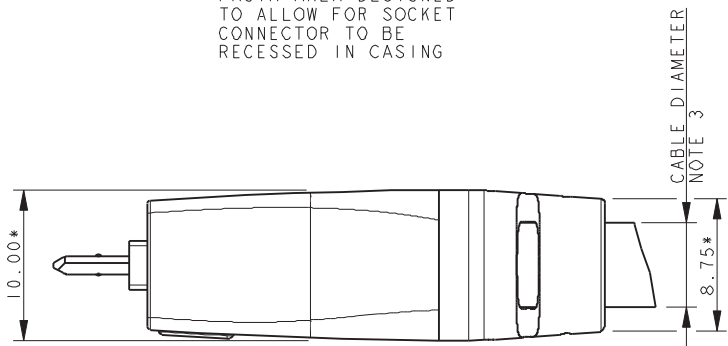
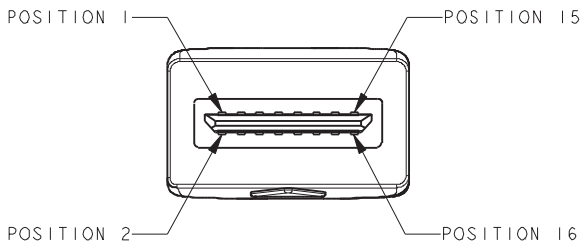

**NOTES:**

1. STANDARD STRAIN RELIEF MOULDING.
2. DIMENSION MARKED WITH A \* ARE VARIABLE DIMENSION TO SUIT CUSTOMER DESIGN AND APPLICATION.
3. TYPICALLY FOR CABLE OUTER JACKET DIAMETERS ABOVE 4.50MM.

# I/O CONNECTORS

## Reduced Size I/O, 16 Position XX-9257

### SUGGESTED OVERMOULDING FOR PLUG CONNECTOR (16 WAY - SLIM STYLE)

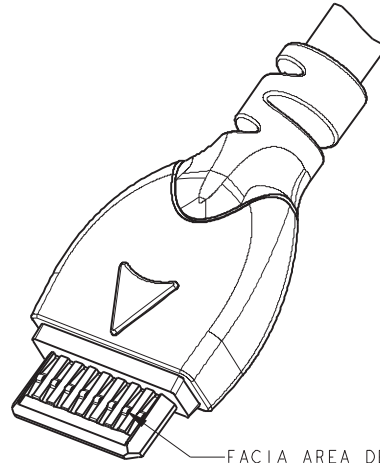
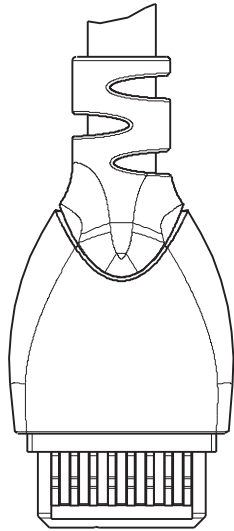

FACIA AREA DESIGNED TO ALLOW FOR SOCKET CONNECTOR TO BE RECESSED IN CASING

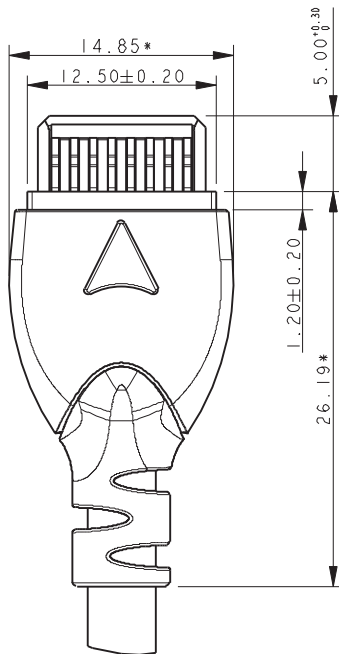
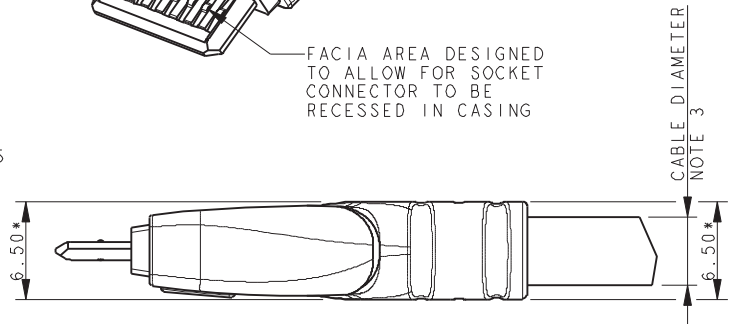
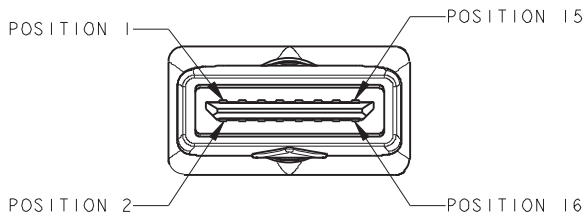

**NOTES:**

1. STANDARD STRAIN RELIEF MOULDING.
2. DIMENSION MARKED WITH A \* ARE VARIABLE DIMENSION TO SUIT CUSTOMER DESIGN AND APPLICATION.
3. TYPICALLY FOR CABLE OUTER JACKET DIAMETERS ABOVE 4.50MM.

# I/O CONNECTORS

## Reduced Size I/O, 16 Position XX-9257

### 16 WAY SOCKET CONNECTOR

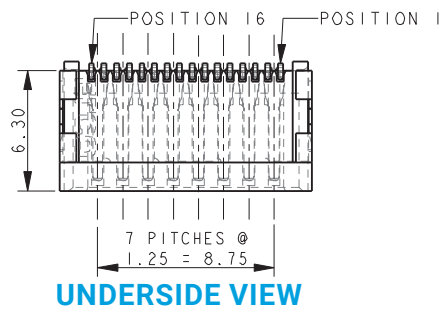
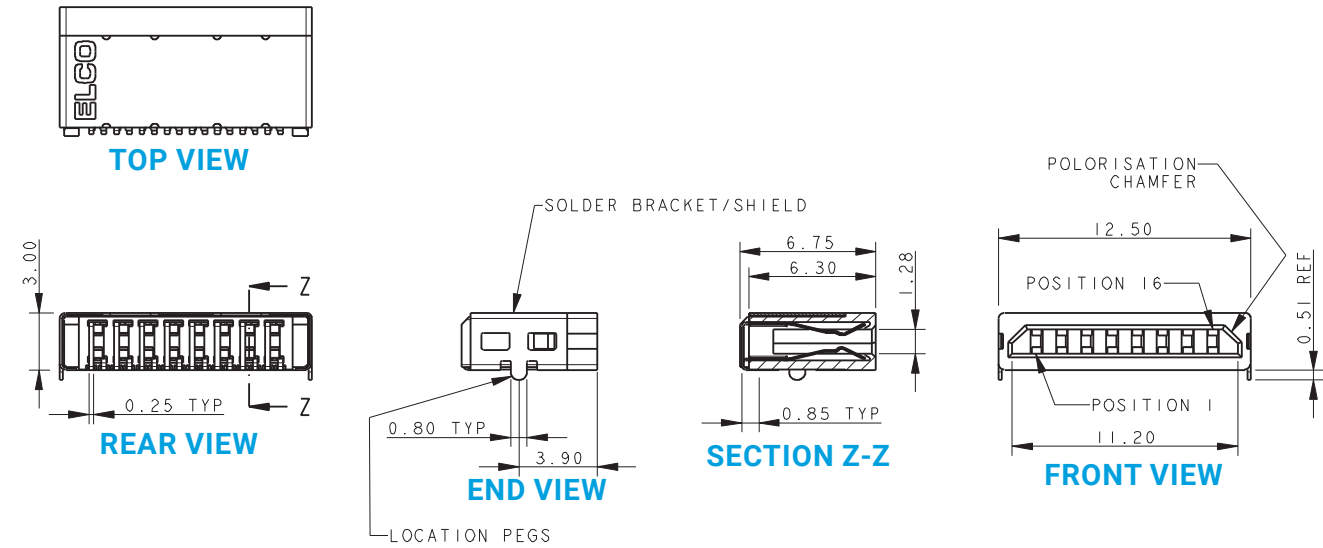

### PCB LAYOUT

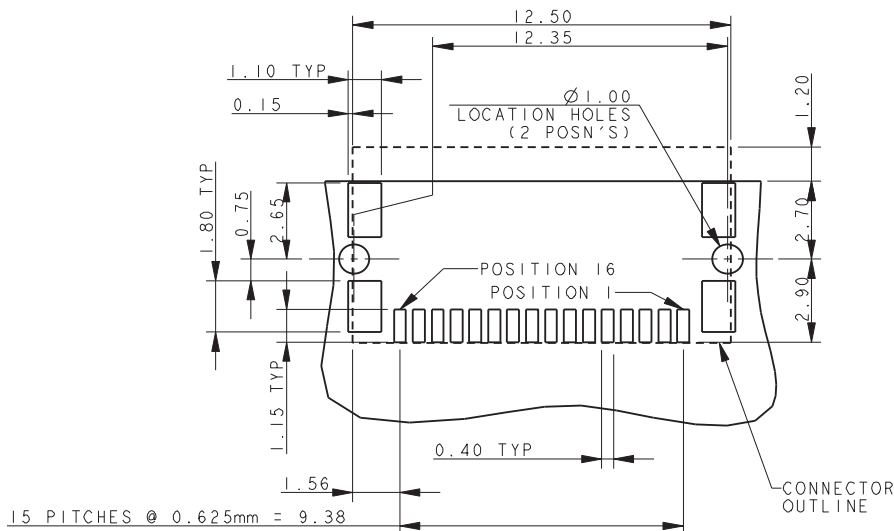

### PACKING DETAILS

REEL QTY	1100
LEADER	33 PKTS
TRAILER	33 PKTS
REELS/BOX	5
PACK QTY	5500

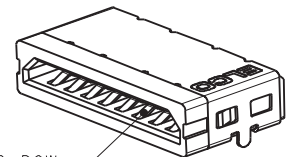
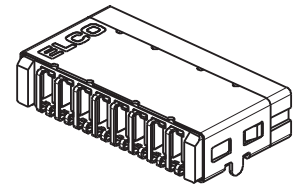
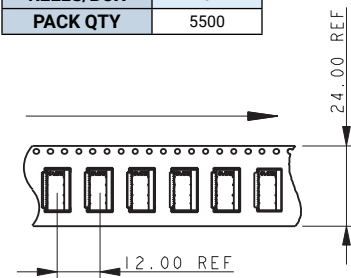

ODD NUMBERED CONTACTS LOWER ROW  
EVEN NUMBERED CONTACTS UPPER ROW

#### NOTES:

1. PROPOSAL FOR 16 WAY I/O SOCKET.
2. FOR FULL PRODUCT SPECIFICATION REFER TO ELECO SPEC 201-01-089.
3. GENERAL TOLERANCE  $\pm 0.20\text{MM}$  UNLESS OTHERWISE STATED.
4. SMT FEET WITHIN  $\pm 0.10\text{MM}$  COPLANARITY.

# I/O CONNECTORS

## Mini I/O, 12 Position XX-9257

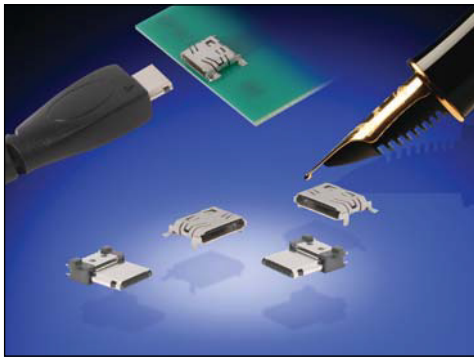

KYOCERA AVX offers the 12 way mini I/O connector as a standard product. The fixed SMT socket is designed to be mounted on a PCB and housed within a portable device. The plug is designed for cable termination with options of single and double sided contacts. Parts can be supplied as connectors only for sub contract termination, or with a custom overmold cover. The socket connector houses 12 contacts in a single row on 0.50mm pitch.

### APPLICATIONS

- Medical Electronics
- Cellular Phones
- Industrial Modules
- Hand Held Devices

### FEATURES AND BENEFITS

- No latching required due to the click design of the contacts.
- Optional customization of the overmold cover.
- Compact size to optimize PCB real estate.
- Metal outer cover provides integrated PCB location and solder tab.
- Positive alignment and orientation of the plug and socket.

### ELECTRICAL

- Current Rating: 0.5 Amp / Contact
- Voltage Rating: 50 VAC

### ENVIRONMENTAL

- Operating Temperature: -55°C to +85°C

### MECHANICAL

- Insulator Material: High Temperature Plastic; UL94 V-0
- Contact Material: Phosphor Bronze (Plug)  
Copper Alloy (Socket)
- Plating: Gold over Nickel
- Durability: 5,000 Cycles

### HOW TO ORDER

#### Plug Options

<b>10</b>	<b>9257</b>	<b>012</b>	<b>101</b>	<b>006</b>	
Prefix	Series	No of Ways	Contact	Contact Plating Option	
10 = Plug		012 = 12 Way	001 = Solder Tail	006 = 0.25µm Gold over Nickel	

#### Socket Options – Example

<b>20</b>	<b>9257</b>	<b>016</b>	<b>101</b>	<b>01</b>	<b>6</b>
Prefix	Series	No of Ways	Contact	Solder Bracket	Plating Option
20 = Socket		012 = 12 Way	101 = SMT Termination	001 = Solder Bracket with Location Pegs	3 = 0.25µm Gold over Nickel

Certification: UL File #E90723

# I/O CONNECTORS

## Mini I/O, 12 Position XX-9257

### 9257 STANDARD 12 WAY MINI I/O PLUG

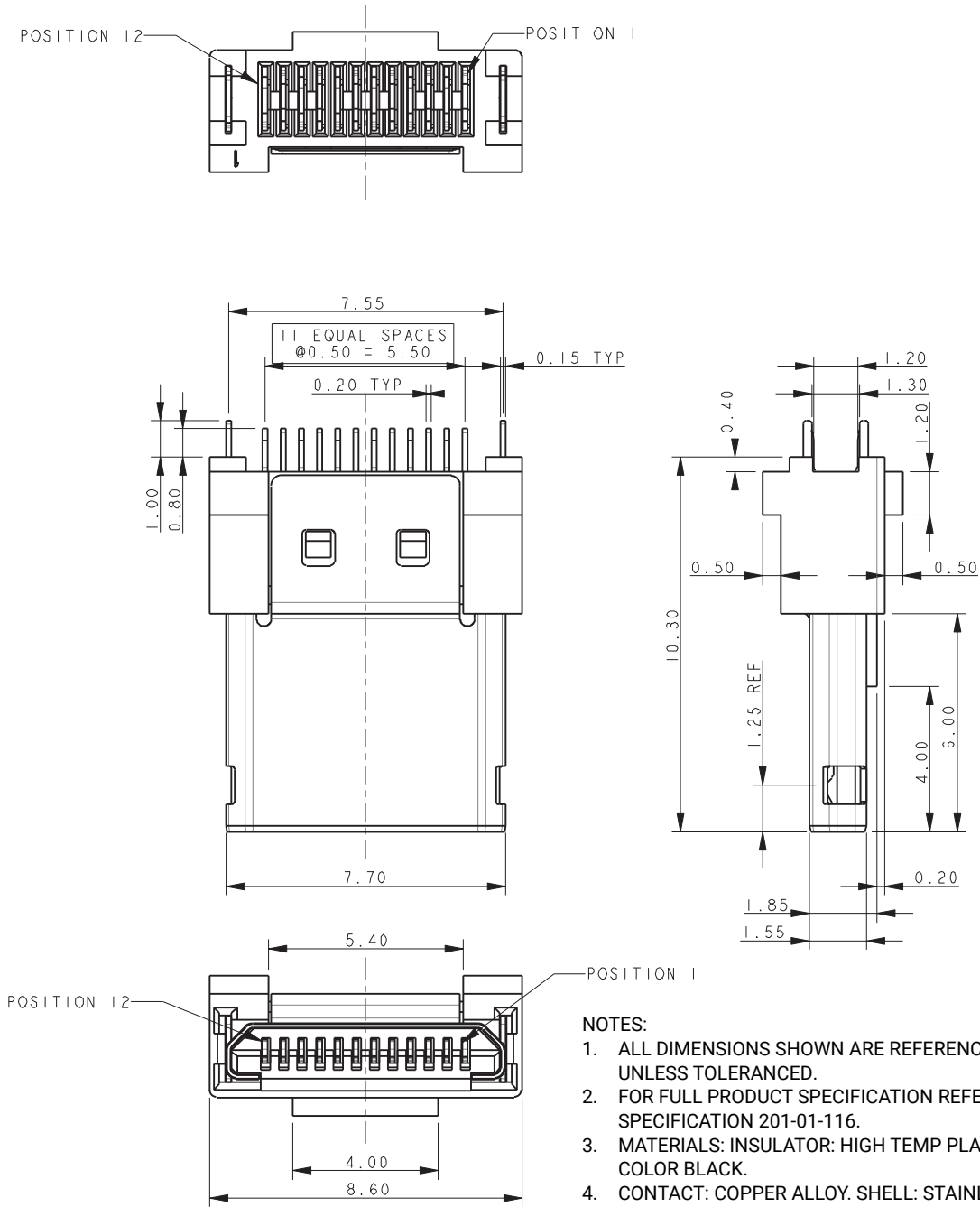

**NOTES:**

1. ALL DIMENSIONS SHOWN ARE REFERENCE DIMENSIONS UNLESS TOLERANCED.
2. FOR FULL PRODUCT SPECIFICATION REFER TO ELCO SPECIFICATION 201-01-116.
3. MATERIALS: INSULATOR: HIGH TEMP PLASTIC, UL94 V-0, COLOR BLACK.
4. CONTACT: COPPER ALLOY. SHELL: STAINLESS STEEL.
5. PLATING: CONTACT: GOLD OVER NICKEL. SHELL: GOLD OVER NICKEL.
6. PACKED IN TUBES, 60 PIECES PER TUBE.

### PACKING DETAILS 60 PARTS PER TUBE



# I/O CONNECTORS

## Mini I/O, 12 Position XX-9257

### SUGGESTED OVERMOULDING FOR PLUG CONNECTOR

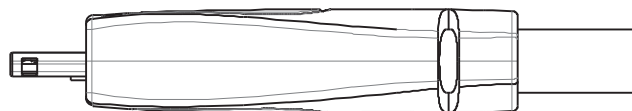
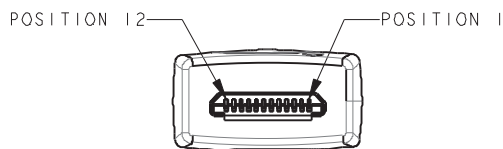
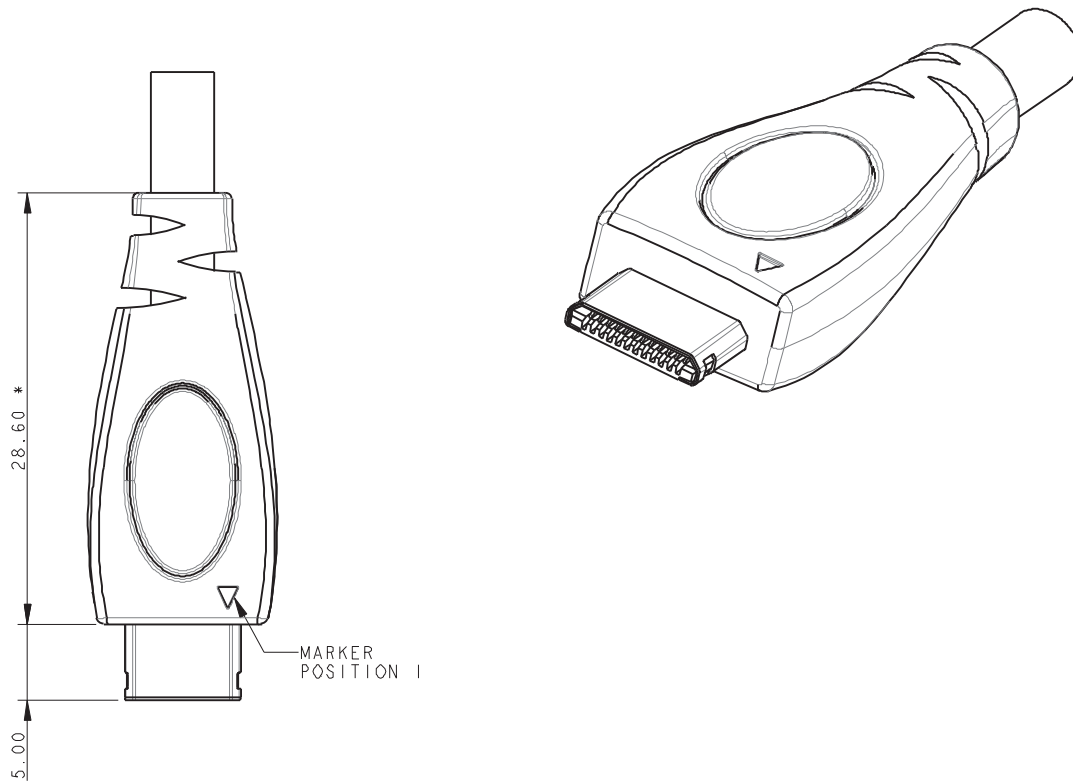

NOTES:  
DIMENSIONS MARKED WITH A \* ARE VARIABLE DIMENSIONS  
TO SUIT CUSTOMER DESIGN AND APPLICATION

# I/O CONNECTORS

## Mini I/O, 12 Position XX-9257

### 9257 STANDARD 12 WAY MINI I/O SOCKET

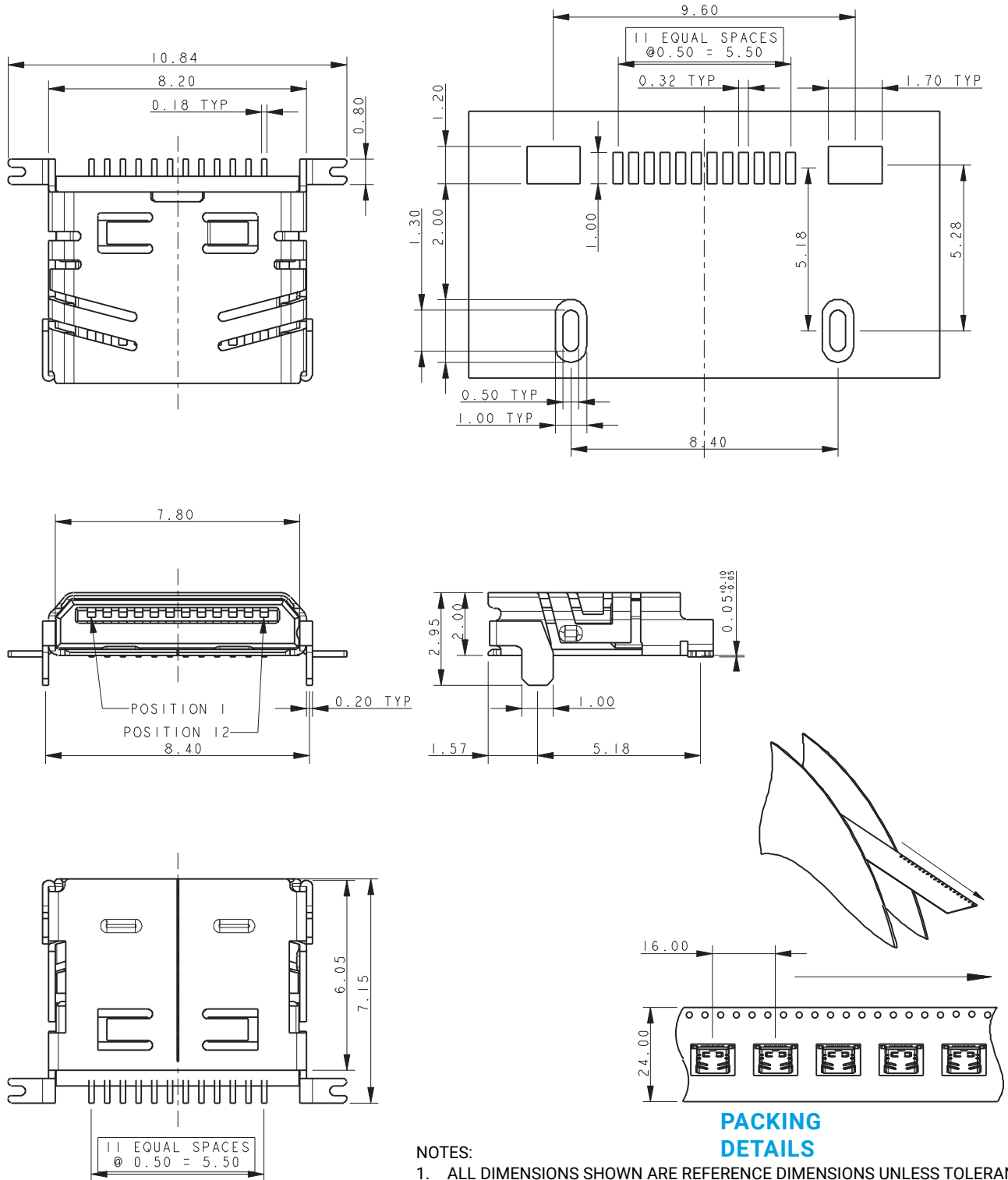

#### PACKING DETAILS

#### NOTES:

1. ALL DIMENSIONS SHOWN ARE REFERENCE DIMENSIONS UNLESS TOLERANCED.
2. FOR FULL PRODUCT SPECIFICATION REFER TO ELCO SPECIFICATION 201-01-116.
3. MATERIALS: INSULATOR: HIGH TEMP PLASTIC, UL94 V-O, COLOR BLACK. CONTACT: COPPER ALLOY. SHELL: STAINLESS STEEL.
4. PLATING: CONTACT: GOLD OVER NICKEL. SHELL: GOLD OVER NICKEL.
5. PACKED IN TAPE AND REEL, 1200 PIECES PER REEL.



# SIM CARD CONNECTORS

## SIM BLOCK 9162-000

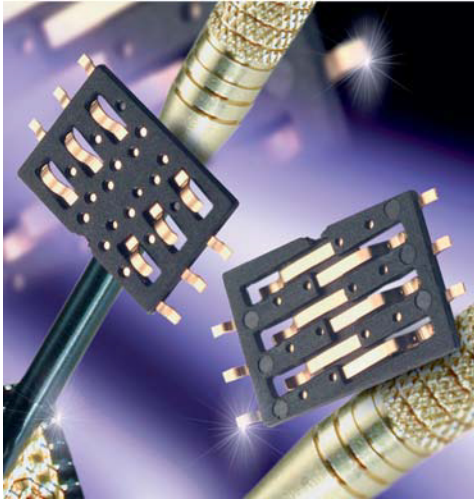

The standard SIM connector is specifically designed for handheld devices requiring secure subscriber identification.

The connectors are available in a standard 6 pin configuration on a 2.54mm pitch with a 0.8mm height.

Contacts are stamped, gold plated, rated at 0.5A, and 5000 mechanical cycles.

Our contact design is specifically rounded to avoid any possible damage during and after card insertion to the card itself, assuming normal use. The design also incorporates protection features to avoid contact damage during this operation such as contact snagging.

Please contact the appropriate sales office for further details.

### APPLICATIONS

- Cellular Phones
- Radios

### FEATURES AND BENEFITS

- Produced for use with both full ISO cards and mini SIM cards.
- The insulator is molded from high temperature plastic enabling the connector to be used in convection or infrared soldering processes.
- Supplied on tape and reel packaging for pick and place assembly.
- RoHS Compliant.

### ELECTRICAL

- Current Rating: 0.5 Amp / Contact
- Voltage Rating: 50 VAC

### ENVIRONMENTAL

- Operating Temperature: -55°C to +80°C

### MECHANICAL

- Insulator Material: Glass Filled LCP
- Contact Material: Beryllium Copper
- Plating: Gold over Nickel
- Durability: 5,000 Cycles

### HOW TO ORDER

<b>00</b>	<b>9162</b>	<b>006</b>	<b>006</b>	<b>080</b>
Prefix	Series	Number of Contacts	SIM Type	Connector Height
			006 = SMT Low Profile SIM Pure Tin Contact	080 = 0.80mm



# SIM CARD CONNECTORS

## SIM BLOCK 9162-000

### CONNECTOR HEIGHT 0.80MM

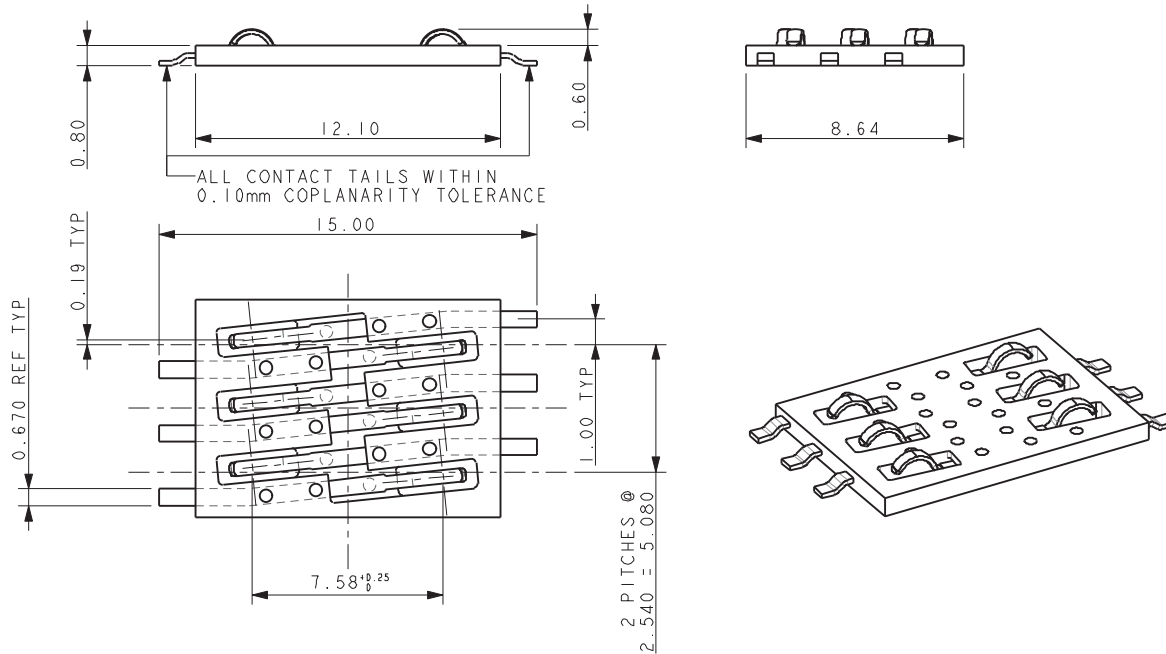

### PACKING DETAILS

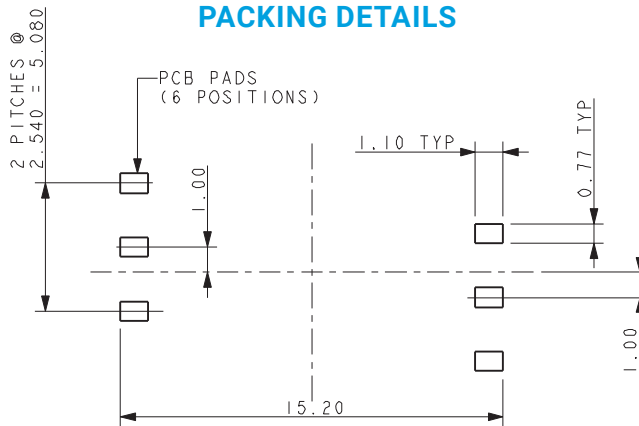

### PACKING DETAILS

REEL QTY	1300
LEADER	500MM
TRAILER	500MM
REELS/BOX	5
PACK QTY	6500

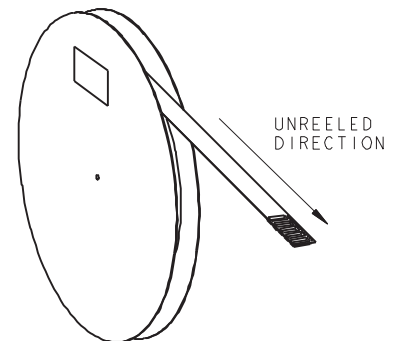
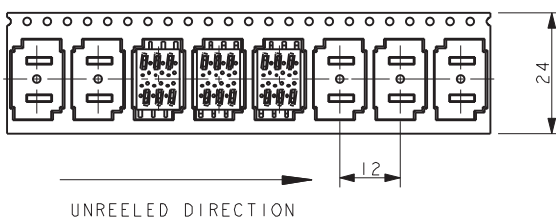

(SHOWING USER DIRECTION OF FEED)

#### NOTES:

1. SALES DRAWING FOR SLIDE IN SIM READER.
2. FOR PRODUCT SPECIFICATION REFER TO ELCO SPEC. 201-01-084.
3. GENERAL TOLERANCE  $\pm 0.20$  UNLESS OTHERWISE STATED.
4. INSULATOR MATERIAL: LCP, GLASS FILLED, COLOR BLACK.
5. CONTACT MATERIAL COPPER ALLOY: SIM CONTACTS NOSE PLATED WITH GOLD, SMT PADS PLATED WITH PURE TIN.

# SIM CARD CONNECTORS

## Slide-In SIM 9162-200



The standard SIM connector is specifically designed for handheld devices requiring secure subscriber identification.

Following on from the introduction of our standard SIM block with an offering of 3 standard heights, 0.80mm, 1.60mm, or 2.40mm, KYOCERA AVX is now adding another standard to the 9162 series SIM connectors, the slide-in SIM.

Unlike SIM blocks which require SIM card guides to aid insertion, removal and retention of the SIM card, the slide-in SIM has guides as part of the connector mold design.

Contacts are stamped, gold plated, rated 0.5A, and 5000 mechanical cycles.

Our contact design is specifically rounded to avoid any possible damage during and after card insertion to the card itself, assuming normal use. The design also incorporates protection features to avoid contact damage during this operation such as contact snagging.

Please contact the appropriate sales office for further details of this service.

### APPLICATIONS

- Cellular Phones
- Radios

### FEATURES AND BENEFITS

- Produced for use with mini SIM cards.
- The insulator is molded from high temperature plastic enabling the connector to be used in convection or infrared soldering processes.
- Supplied on tape and reel packaging for pick and place assembly.
- The all plastic design, assuming normal use prevents damage to the SIM card on insertion.
- Optional SMT contact size:
  - Standard SMT contact size – 1.60mm x 1.60mm
  - Narrow SMT contact size – 1.05mm x 0.60mm
- RoHS Compliant available.

### ELECTRICAL

- Current Rating: 0.5 Amp / Contact
- Voltage Rating: 50 VAC

### ENVIRONMENTAL

- Operating Temperature:  
-55°C to +105°C

### MECHANICAL

- Insulator Material: Nylon 46 UL94HB
- Contact Material: Phosphor Bronze
- Plating: Gold over Nickel
- Durability: 5,000 Cycles

### HOW TO ORDER

<b>00</b>	<b>9162</b>	<b>006</b>	<b>2X</b>	<b>6</b>	<b>175</b>
Prefix	Series	Number of Contacts	SIM Type	Plating Option	Connector Height
			20 = Standard SMT Foot Slide-in SIM Reader 21 = Narrow SMT Foot Slide-in SIM Reader	6 = Selective Gold Pure Tin Tails	175 = 1.750mm See pages 64 & 65



# SIM CARD CONNECTORS

## Slide-In SIM 9162-200

### WIDE SMT FOOT VERSION

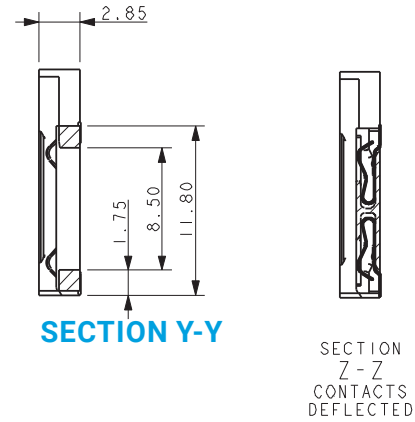
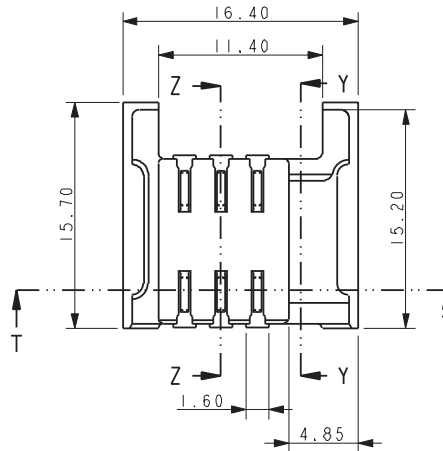
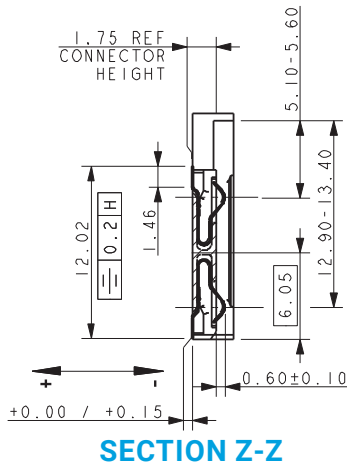

CONTACT TAILS WITHIN 0.10mm COPLANARITY TOLERANCE SINGLE ROW

### PART SECTION Z-Z ROTATED THRU 90°

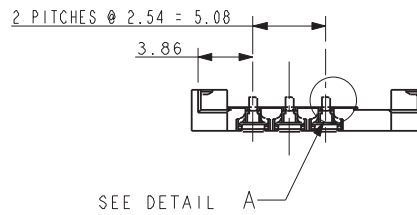
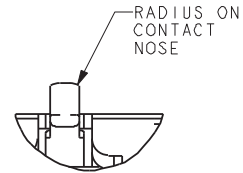
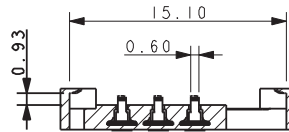

### CONTACT FUNCTIONS (ISO78161):

1. SSUPPLY VOLTAGE Vcc.
2. RESET
3. CLOCK
4. GROUND
5. PROGRAM VOLTAGE Vpp.
6. I/O

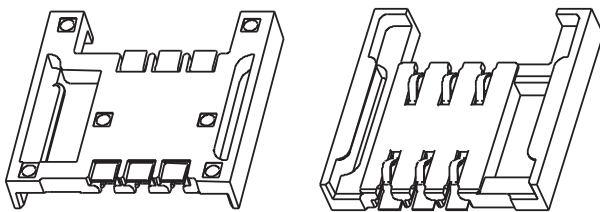

### PAD LAYOUT

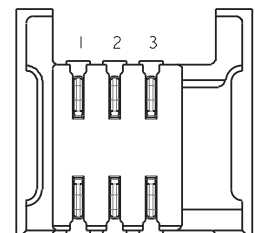
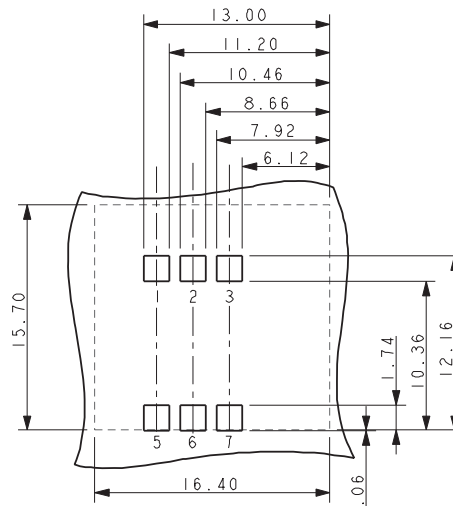

### NOTES:

1. SALES DRAWING FOR SLIDE IN SIM READER.
2. FOR PRODUCT SPECIFICATION REFER TO ELCO SPEC. 201-01-085.
3. GENERAL TOLERANCE  $\pm 0.20$  UNLESS OTHERWISE STATED.
4. INSULATOR MATERIAL: NYLON GLASS FILLED.
5. CONTACT MATERIAL COPPER ALLOY: SIM CONTACTS NOSE PLATED WITH GOLD, SMT PADS PLATED WITH PURE TIN.
6. PACKING DETAILS SEE PAGE 75.

# SIM CARD CONNECTORS

## Slide-In SIM 9162-200

### NARROW SMT FOOT VERSION

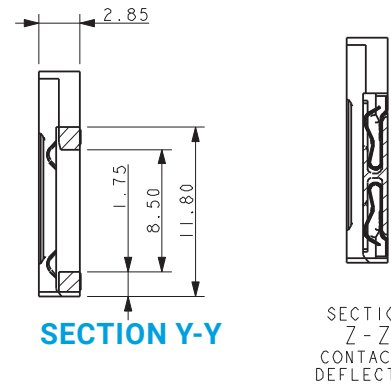
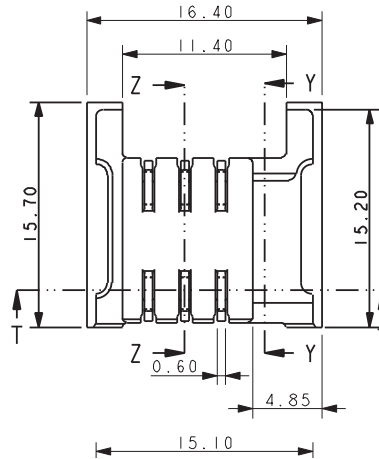
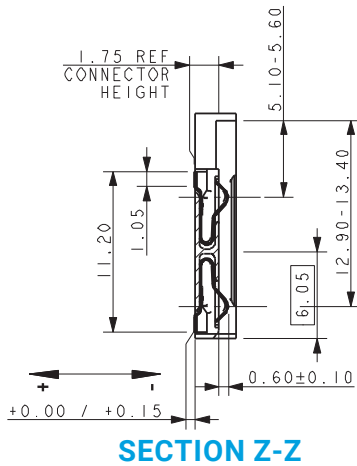

DEFLECT



CONTACT TAILS WITHIN 0.10mm COPLANARITY TOLERANCE SINGLE ROW

PART SECTION Z-Z ROTATED THRO' 90°

### PART SECTION Z-Z ROTATED THRO' 90°

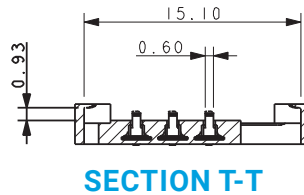

RADIUS ON CONTACT NOSE



### DETAIL A

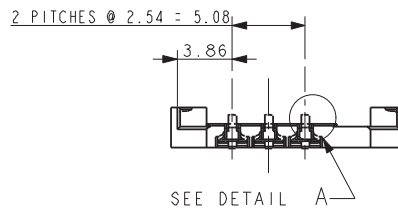

CONTACT FUNCTIONS (ISO78161):

1. SSUPPLY VOLTAGE Vcc.
2. RESET
3. CLOCK
4. GROUND
5. PROGRAM VOLTAGE Vpp.
6. I/O

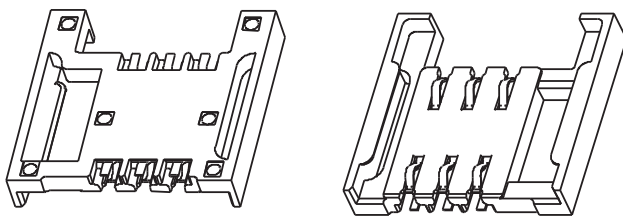

### PAD LAYOUT

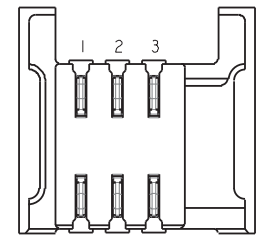
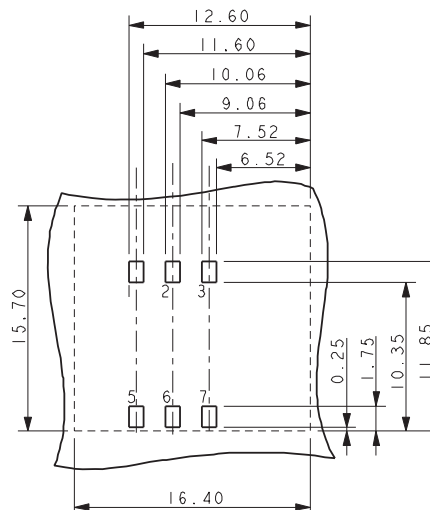

SIM ORIENTATION

#### NOTES:

1. SALES DRAWING FOR SLIDE IN SIM READER.
2. FOR PRODUCT SPECIFICATION REFER TO ELCO SPEC. 201-01-085.
3. GENERAL TOLERANCE  $\pm 0.20$  UNLESS OTHERWISE STATED.
4. INSULATOR MATERIAL: NYLON GLASS FILLED.
5. CONTACT MATERIAL COPPER ALLOY: SIM CONTACTS NOSE PLATED WITH GOLD, SMT PADS PLATED WITH PURE TIN.
6. PACKING DETAILS SEE PAGE 75.

# SIM CARD CONNECTORS

## Slide-In SIM 9162-200

### PACKING DETAILS

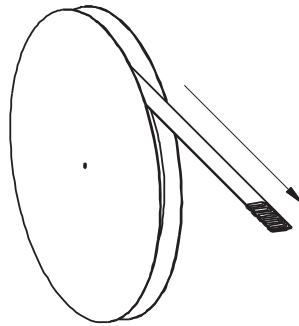

(SHOWING USER DIRECTION OF FEED)

#### Reel Size 380mm Dia.

REEL QTY	1100
LEADER	500MM
TRAILER	500MM
REELS/BOX	4
PACK QTY	4400

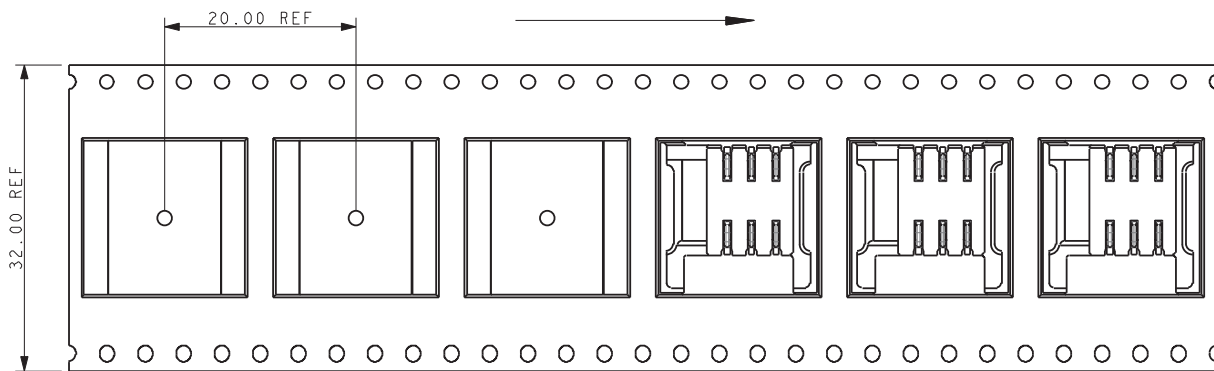

# SIM CARD CONNECTORS

## Locking SIM 9162-300



For 9162 Slide-IN & 9162 SIM/microSD

- Accepts GSM Standard 11.11 cards
- Secure locking latch mechanism
- Robust, good resistance against shock and vibration
- SIM Installed Height – 1.50mm
- Polarized to eliminate improper insertion of the card

### APPLICATIONS

- Cellular Phones
- Radios

### FEATURES AND BENEFITS

- SMT with locking hinged guide
- 2.50mm connector height
- Selective gold on mating surface/tin on solder tails
- Tape and reel packaging

### ELECTRICAL

- Current Rating: 0.3 Amp / Contact
- Voltage Rating: 30 VAC

### ENVIRONMENTAL

- Operating Temperature:  
-55°C to +125°C

### MECHANICAL

- Insulator Material: High Temperature Plastic; UL94 V-0
- Contact Material: Copper Alloy
- Plating: Gold over Nickel
- Durability: 10,000 Cycles

### HOW TO ORDER

<b>00</b>	<b>9162</b>	<b>006</b>	<b>30</b>	<b>1</b>	<b>150</b>
Prefix	Series	Number of Contacts	SIM Type	Contact Plating	SIM Height
			30 = SMT with Locking Hinge SIM Guide	1 = Selective Gold on Contact Surface and Tin on Solder Tails	150 = 1.50mm on SIM Card 2.50mm on Connector

# SIM CARD CONNECTORS

## Locking SIM 9162-300

### CONNECTOR DETAILS

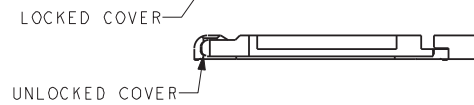
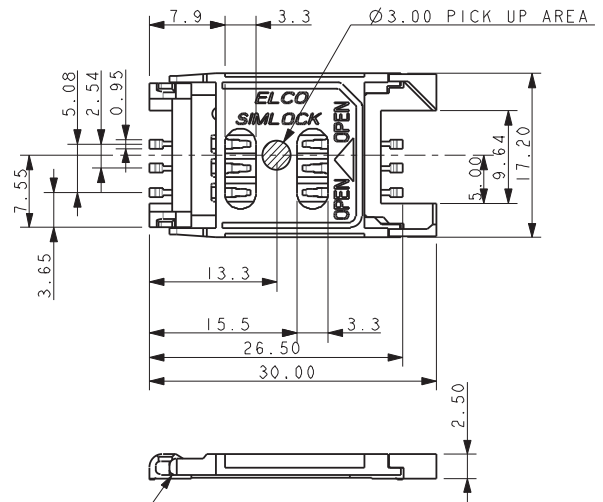
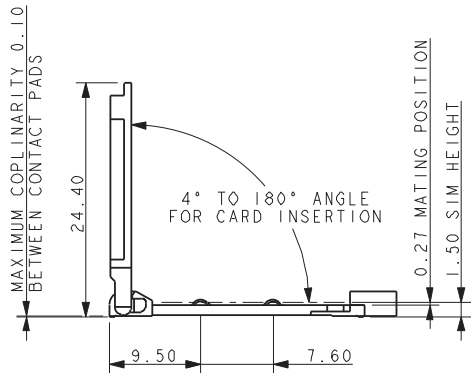

### SUGGESTED PCB LAYOUT

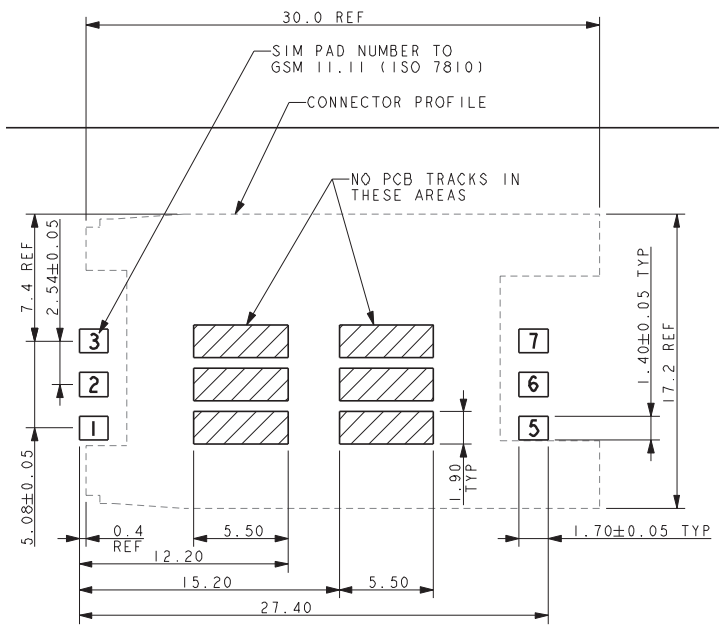

#### NOTES:

1. SALES DRAWING FOR SIMLOCK SIM READER.
2. ALL DIMENSIONS ARE REFERENCE DIMENSIONS UNLESS TOLERANCED.
3. FOR PRODUCT SPECIFICATION REFER TO ELCO SPEC. 201-01-111.
4. PACKING IN TAPE AND REEL, 600 PIECES IN A 330MM REEL.
5. MATERIAL: COVER AND HOUSING: HIGH TEMPERATURE THERMOPLASTIC UL94 V-0, COLOR BLACK. CONTACT: COPPER ALLOY, GOLD PLATING IN CONTACT AREA, TIN PLATING ON SOLDER TAILS, NICKEL UNDERCOAT ON ALL SURFACES.

### PACKING DETAILS

#### CONTACT FUNCTIONS (ISO78161):

1. SSUPPLY VOLTAGE  $V_{cc}$ .
2. RESET
3. CLOCK
4. GROUND
5. PROGRAM VOLTAGE  $V_{pp}$ .
6. I/O

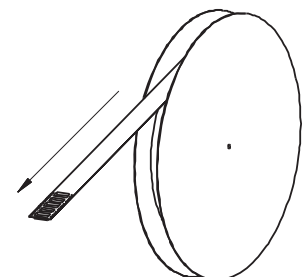
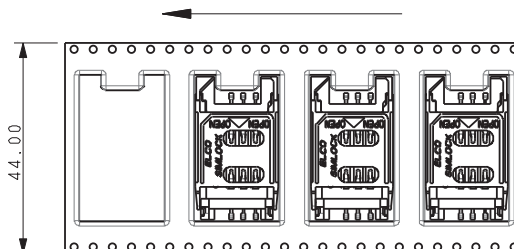



# SIM CARD CONNECTORS

## Slide-In Low Profile SIM 9162-400

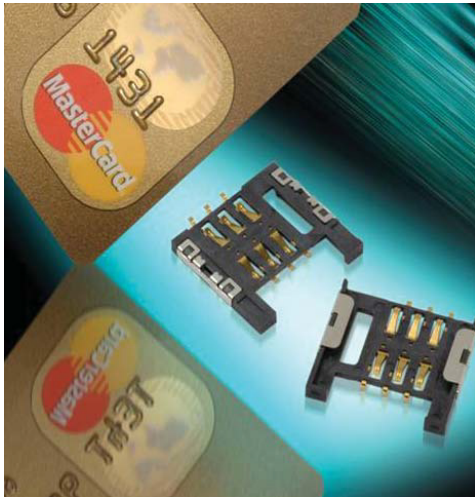

- Six position Slide-In SIM
- Low Profile – 0.70mm to SIM base
- Side bracket to add solder security
- SIM guidance using the side walls

### APPLICATIONS

- Cellular Phones
- Radios

### FEATURES AND BENEFITS

- SMT Slide-In SIM
- Molded in high temperature LCP
- 0.38 $\mu$ m Gold on contact surface and gold flash on contact tails
- 1.60mm connector height
- Tape & Reel packaging

### ELECTRICAL

- Current Rating: 0.3 Amp / Contact
- Voltage Rating: 15 VAC

### ENVIRONMENTAL

- Operating Temperature: -55°C to +70°C

### MECHANICAL

- Insulator Material: High Temperature Plastic; UL94 V-0
- Contact Material: Copper Alloy
- Plating: Gold over Nickel
- Durability: 10,000 Cycles

### HOW TO ORDER

**00** Prefix  
**9162** Series  
**006** Number of Contacts  
**40** SIM Type  
 40 = SMT Slide-in SIM

**1** Contact Plating  
 1 = 0.38 $\mu$ m Gold on Contact Surface and Gold Flash on Solder Tails. Underplated 1.27 $\mu$ m Nickel.

**070** SIM Height  
 070 = 0.70mm on SIM Card  
 1.60mm on Connector

# SIM CARD CONNECTORS

## Slide-In Low Profile SIM 9162-400

### CONNECTOR DETAILS

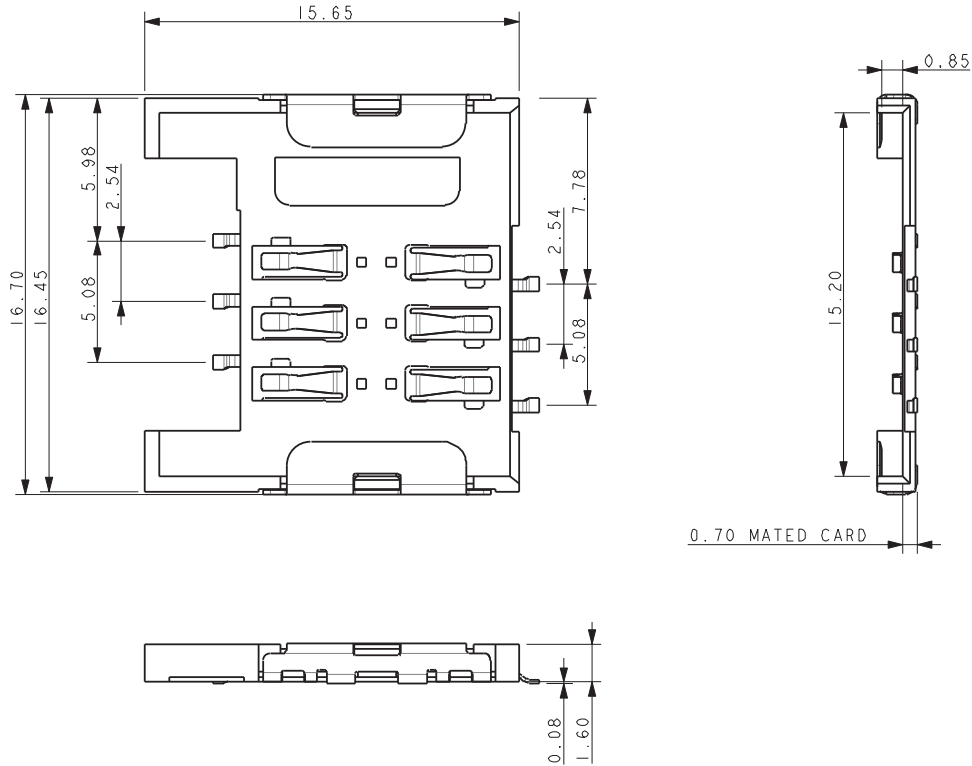

#### NOTES:

1. DIMENSIONS SHOWN ARE REFERENCED DIMENSIONS.
2. INSULATOR MATERIAL: LCP, UL94 V-0, COLOR BLACK.
3. CONTACT MATERIAL: PHOSPHOR BONZE.
4. CONTACT PLATING: NICKEL ALL OVER, GOLD ON CONTACT, GOLD FLASH ON TAILS.
5. PADS: NICKEL PLATED STAINLESS STEEL, PURE TIN PLATING.
6. COPLANARITY OF PADS 0.10 MAXIMUM.
7. FOR FULL PRODUCT SPECIFICATION REFER TO ELCO SPEC 201-01-112.

### SUGGESTED PCB LAYOUT

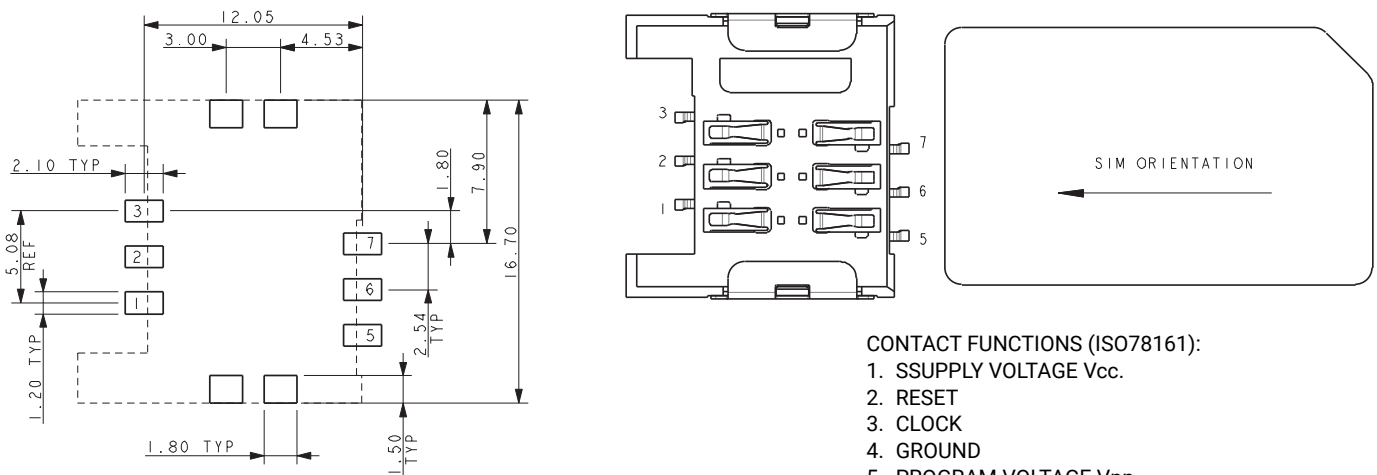

#### CONTACT FUNCTIONS (ISO78161):

1. SSUPPLY VOLTAGE  $V_{cc}$ .
2. RESET
3. CLOCK
4. GROUND
5. PROGRAM VOLTAGE  $V_{pp}$ .
6. I/O

# SIM CARD CONNECTORS

## Slide-In Low Profile SIM 9162-400

### PACKING DETAILS

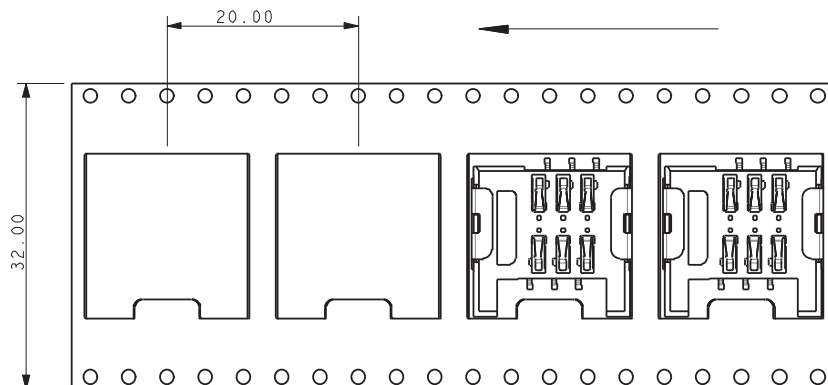
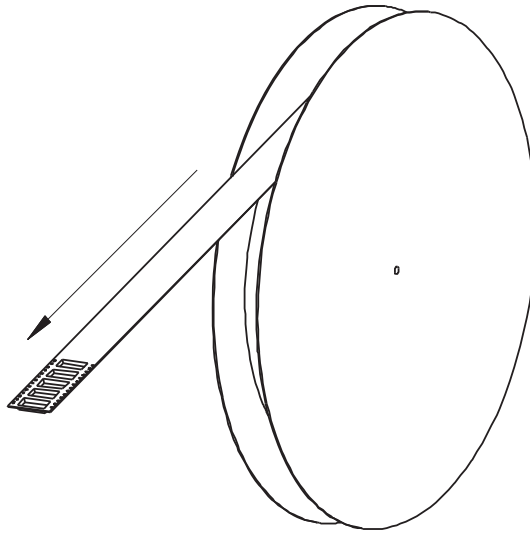

#### NOTES:

1. TO BE PACKED IN TAPE AND REEL.
2. 1000 PIECES ON A 330MM REEL.
3. COMPONENT DIRECTION AS SHOWN.

# SIM CARD CONNECTORS

## SIM/Micro SD Combination 9162-500



- Six position slide-in SIM connector & Push-Push microSD connector
- Allows two cards to be inserted into the same connector
- Card detect switch on the microSD

### APPLICATIONS

- Cellular Phones
- Radios

### FEATURES AND BENEFITS

- Space saving connector combination
- Integrates 2 connectors into 1
- Contact Plating: Gold
- Insulator molded from LCP UL94 V-0
- Low profile 1.50mm to SIM
- 2.70mm connector height

### ELECTRICAL

- Current Rating: 0.3 Amp / Contact
- Voltage Rating: 15 VAC

### ENVIRONMENTAL

- Operating Temperature: -55°C to +70°C

### MECHANICAL

- Insulator Material: LCP; UL94 V-0
- Contact Material: Beryllium Copper
- Plating: Gold over Nickel
- Durability: SIM @10,000 Cycles / SD @ 6000 Cycles

### HOW TO ORDER

**00**  
Prefix

**9162**  
Series

**006**  
Number of  
Contacts

**50**  
SIM Type  
50 = SMT with SIM  
and Micro SD  
Slots at 90°

**1**  
Contact Plating  
1 = Gold Plating over Nickel

**150**  
SIM Height  
150 = 1.50mm on SIM Card  
2.70mm on Connector

# SIM CARD CONNECTORS

## SIM/Micro SD Combination 9162-500

### CONNECTOR DETAILS

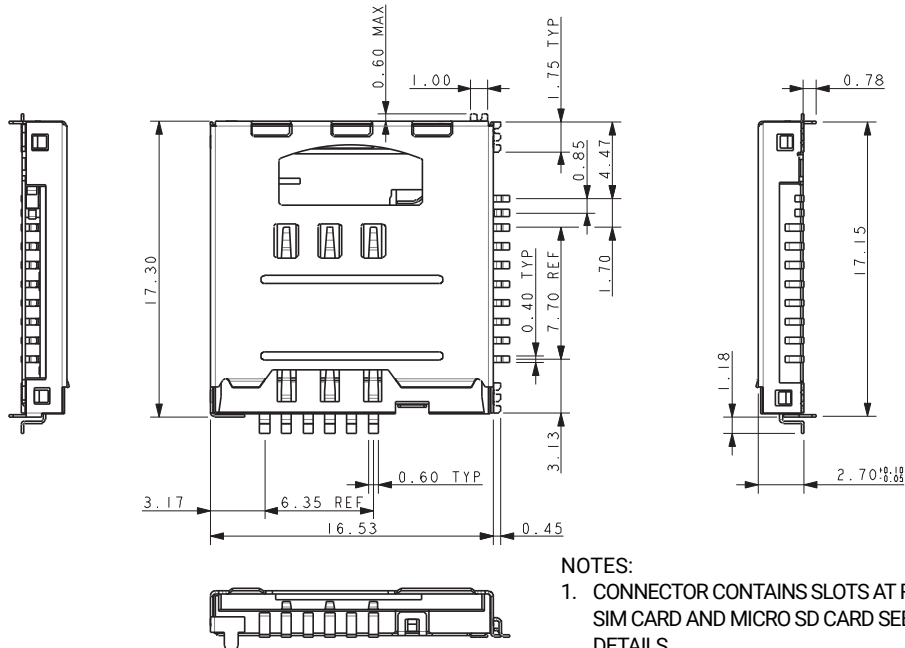

#### NOTES:

- CONNECTOR CONTAINS SLOTS AT RIGHT ANGLES FOR A SIM CARD AND MICRO SD CARD SEE PAGE 83 FOR FURTHER DETAILS.
- 6 WAY SIM CONNECTOR.
- MICRO SD CONNECTOR HAS SWITCH AND LATCH.
- DIMENSION SHOWN AS REFERENCE DIMENSIONS.
- MATERIALS: CONTACTS: GOLD PLATED BERYLLIUM COPPER, INSULATOR: LCP UL94 V-0, COLOR BLACK. SHELL: NICKEL PLATED STAINLESS STEEL. OTHER PARTS: STAINLESS STEEL.
- FURTHER DETAILS REFER TO ELCO SPEC 201-01-113.
- DETAILS OF PIN FUNCTIONS REFER TO PAGE 83.

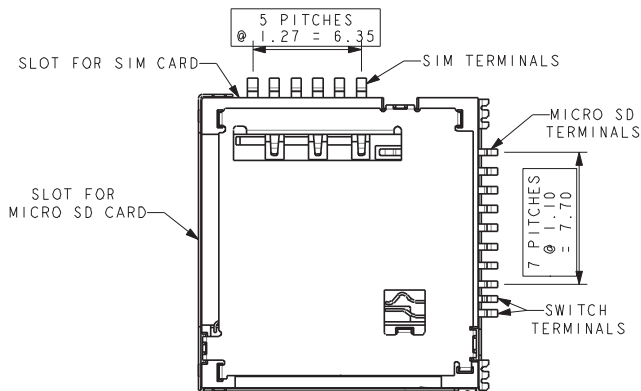

### CONNECTOR ON PCB

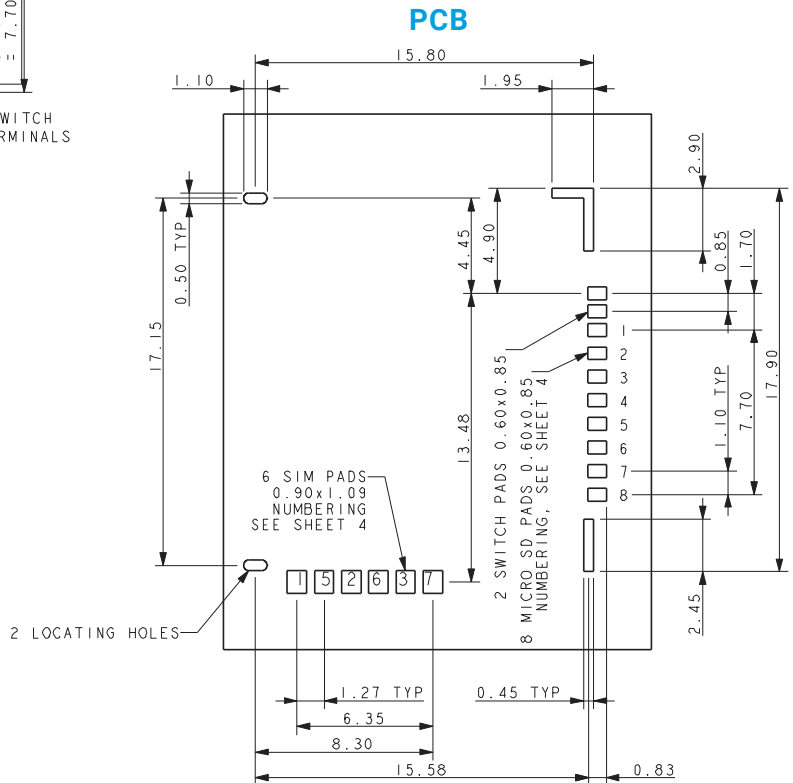
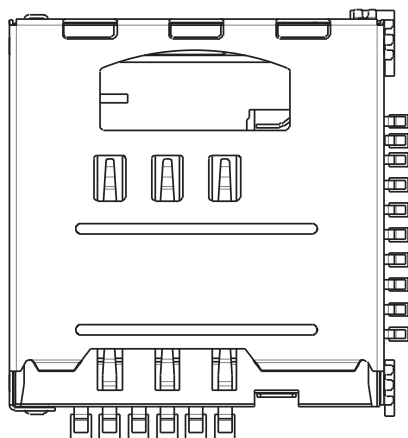

# SIM CARD CONNECTORS

## SIM/Micro SD Combination 9162-500

### PCB SPACE USED BY CONNECTOR CARDS FULLY INSERTED

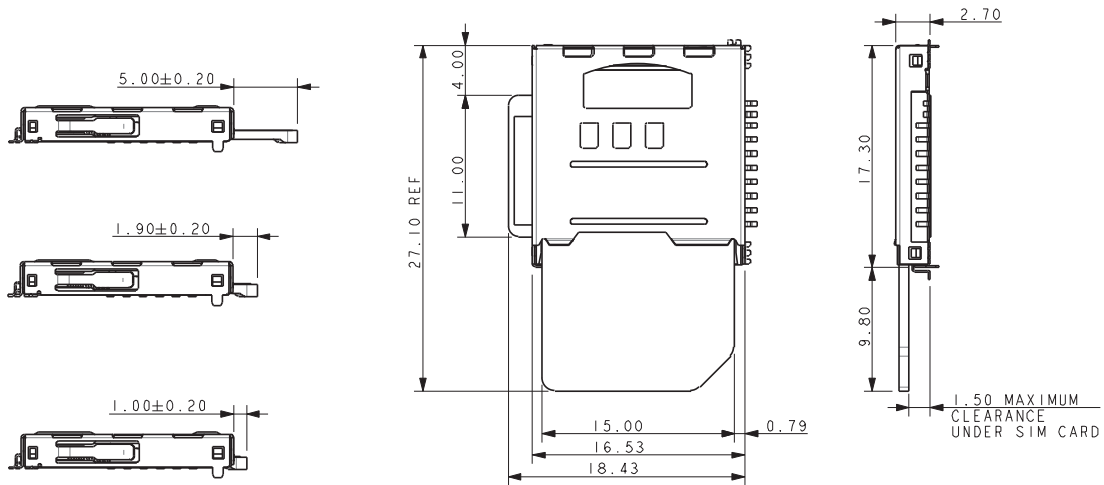

### CARDS EXTRACTED

SHOWN FOR REFERENCE ONLY

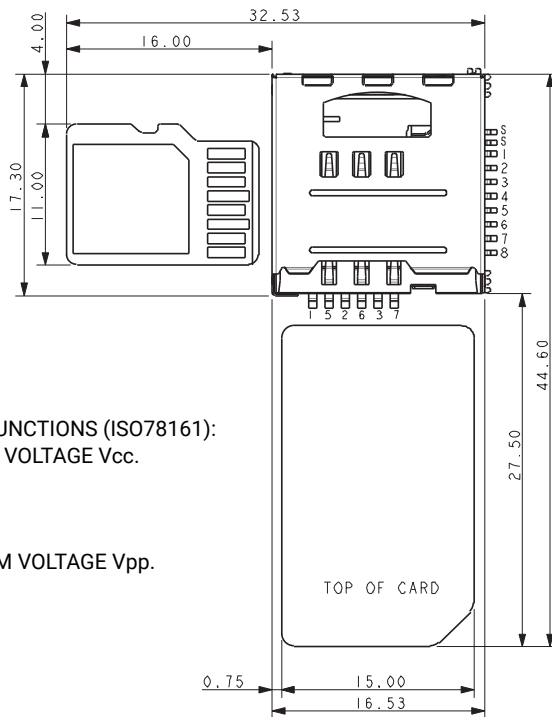

#### CONTACT FUNCTIONS (ISO78161):

1. SSUPPLY VOLTAGE Vcc.
2. RESET
3. CLOCK
4. GROUND
5. PROGRAM VOLTAGE Vpp.
6. I/O

#### MICRO SD FUNCTIONS:

- S. SWITCH
- S. SWITCH
1. DAT2
2. CD/DAT3
3. CMD
4. Vdd
5. CLOCK
6. Vss
7. DAT0
8. DAT1

### PACKING DETAILS

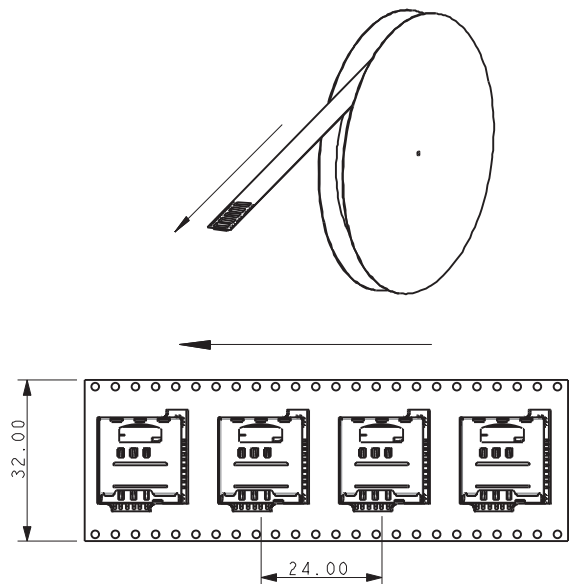

#### NOTES:

1. PACKING IN TAPE AND REEL, 700 PER REEL.
2. REEL SIZE 330MM DIAMETER.

# WTB COAX CONNECTORS

## IDC SMT COAX 1 Position 00-9178

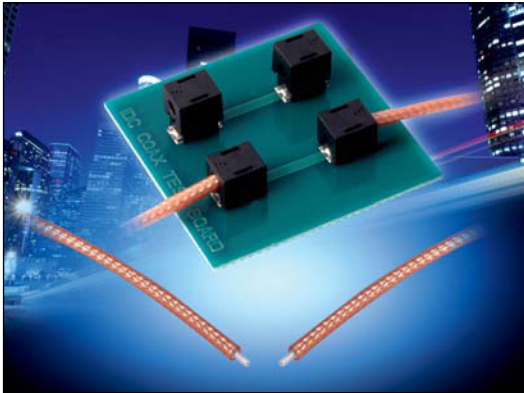

KYOCERA AVX has developed a unique 50 Ohm SMT Coax Connector based on our industry proven discrete wire Insulation Displacement Connector (IDC) technology. By combining two different sized IDC contacts, we can reliably pierce the center conductor and outside jacket dielectric materials to make electrical connection to the signal wire and braid (ground connection). Designed specifically for RG178 cable, the concept can be applied to other cable sizes.

The connector comes with a pre-attached cap in tape & reel packaging. The coax cable only needs the outer jacket and braid stripped. The cable is then inserted into the connector and the cap can be pressed down via a small press or hand tool. The biggest advantage of this connector is that it is extremely easy to terminate, no soldering, additional stripping processes or crimp tools are needed. The all plastic design is more cost effective than plated screw machine components while providing a VSWR less than 1.2:1 in excess of 700MHz.

### APPLICATIONS

- Reliable & Repeatable termination of RG178 coax cable to a PCB to replace hard solder connections
- Cost effective replacement of standard coax connectors in low frequency applications for RG178 cable
- Standard Microminiature type RF products: GPS, Radio Boards, Meters, RFID and data communications
- Application notes: refer to 201-01-131

### FEATURES AND BENEFITS

- “Gas Tight” IDC termination for long term reliability
- Simple strip, insert and press down termination process
- High temperature endurance testing for 1000 hrs at 125°C
- Industrial operating temperature range for harsh environments

### ELECTRICAL

- Current Rating: 0.5A
- (Current limit is cable dependent)
- Voltage Rating: 125V
- VSWR less than 1.2:1 in excess of 700MHz

### ENVIRONMENTAL

- Operating Temperature: -40°C to +125°C

### MECHANICAL

- Insulator Material: Nylon 46: UL94 V-0
- Contact Material: Phosphor Bronze, Tin Plated
- Latching Cap: Single Use
- Cable retention: 10N in each axis

### HOW TO ORDER

**00**  
Prefix

**9178**  
Series

**001**  
Number of Ways

Code	No of Ways	Details
001	1	Page 76

**00X**  
Cable Type

001 = RG178B/U  
(M17/93-RG178)

**X**  
Contact Plating

Code	Color	Application
0	Black	Industrial
1	White	Lighting

**06**  
Plating Option

06 = Pure Tin all over

# WTB COAX CONNECTORS

## IDC SMT COAX 1 Position 00-9178

### CONNECTOR DETAILS - RG178B/U

CABLE INSERTION DIRECTION  
ALSO REFER TO PAGE 77 FOR  
PACKING ORIENTATION

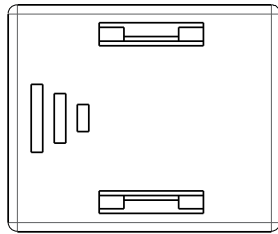

**NOTES:**

1. CONNECTOR FOR RG178B/U (M17/93-RG178) MIL SPEC COAX CABLE. FOR OTHER CABLES REFER TO KYOCERA AVX FOR FURTHER INFORMATION.
2. FOR FURTHER DETAILS REFER TO ELCO PRODUCT SPECIFICATION 201-01-130 AND APPLICATION NOTES 201-01-131.
3. GENERAL TOLERANCE  $\pm 0.20$  UNLESS SPECIFIED.
4. CONNECTOR SUPPLIED AS SHOWN WITH THE CAP IN THE UP POSITION.

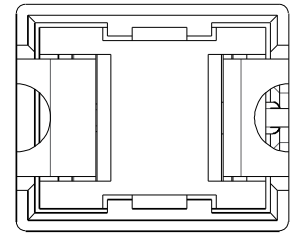
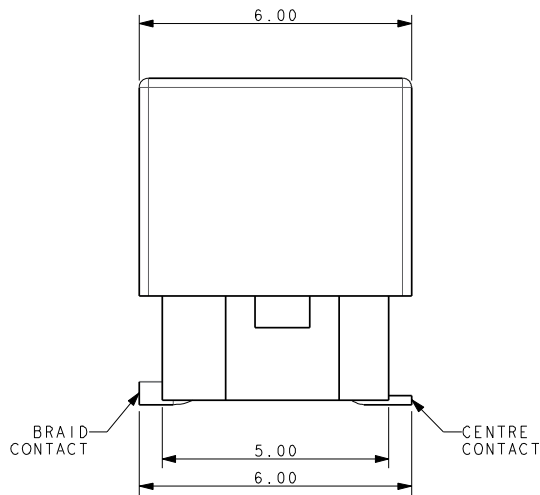
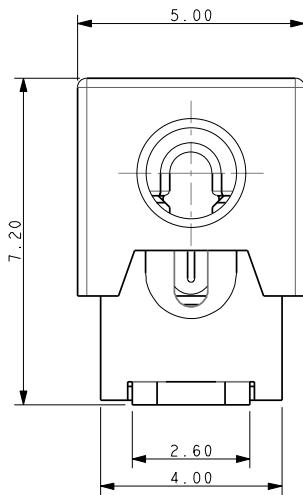

### WIRED CONNECTOR

TRIM LENGTH  $2.30 \pm 0.20$   
BRAID AND OUTER JACKET ONLY

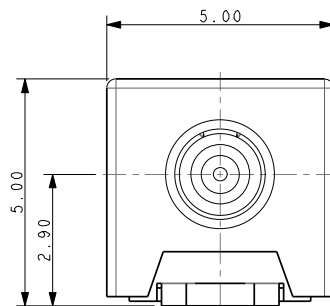
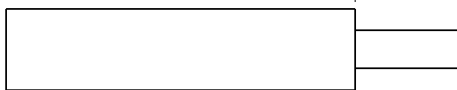

**NOTES:**

1. CONNECTOR SHOWN IN ASSEMBLED CONDITION, CAP PUSHED DOWN.
2. CAP LOCKS IN LOWER POSITION, TERMINATION CANNOT BE REMADE.
3. FOR FULL DETAILS REFER TO APPLICATION NOTES 201-01-131.
4. CONNECTOR FOR RG178B/U (M17/93-RG178) MIL SPEC COAX CABLE ONLY.
5. ALL LOOSE MATERIAL MUST BE REMOVED FROM TRIMMED CABLE.

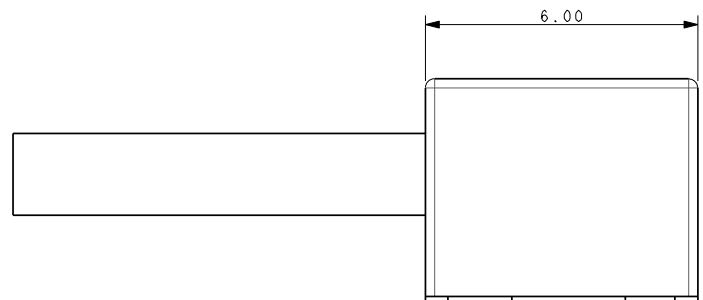
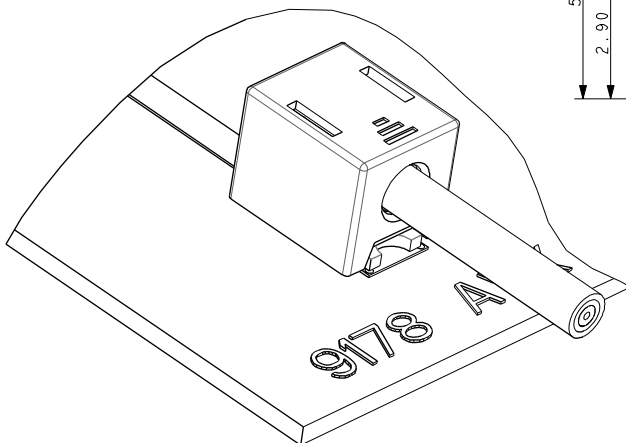



**SUGGESTED PCB LAYOUT**

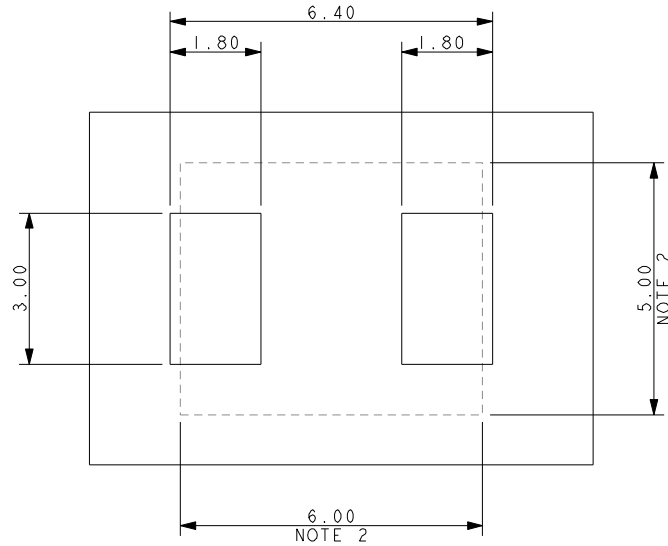

**NOTES:**

1. PADS SHOWN FOR CONNECTOR FEET ONLY, OTHER DETAILS WILL DEPEND ON THE CUSTOMERS PCB SPECIFICATION AND PERFORMANCE REQUIREMENTS.
2. OUTLINE OF THE CONNECTOR.
3. TYPICAL CIRCUIT CONFIGURATION:
4. BRAID CONNECTED THROUGH BOARD TO GROUND PLANE. CENTER CONDUCTOR TRACK 1.5MM WIDE ON 0.8MM THICK PCB

**PACKING DETAILS**

REEL QTY	700
LEADER	480MM
TRAILER	120MM

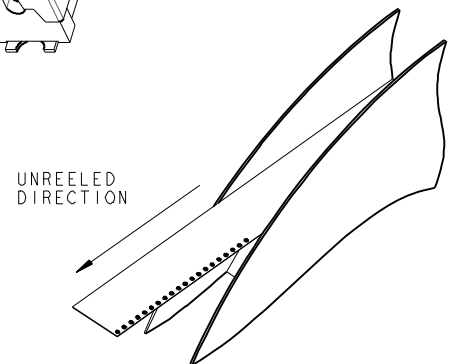
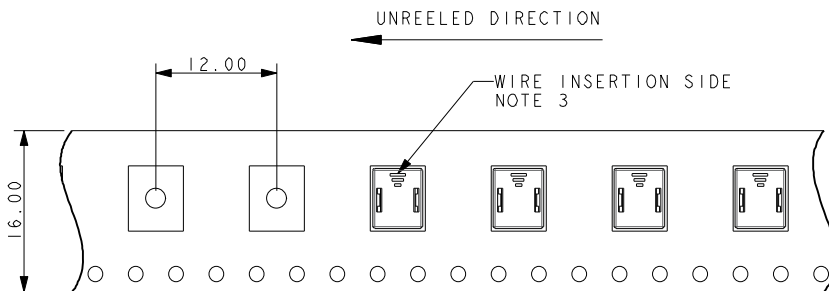
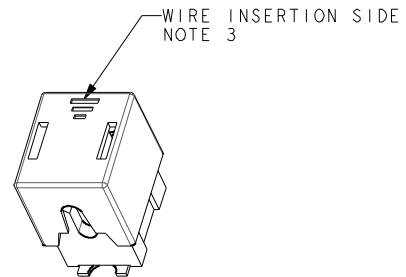

**NOTES:**

1. PACKING IN TAPE AND REEL.
2. PIECES PER REEL.
3. PARTS TO BE IN THE CORRECT ORIENTATION.

# WTB COAX CONNECTORS

## IDC SMT COAX 1 Position 00-9178

### HAND ASSEMBLY TOOL

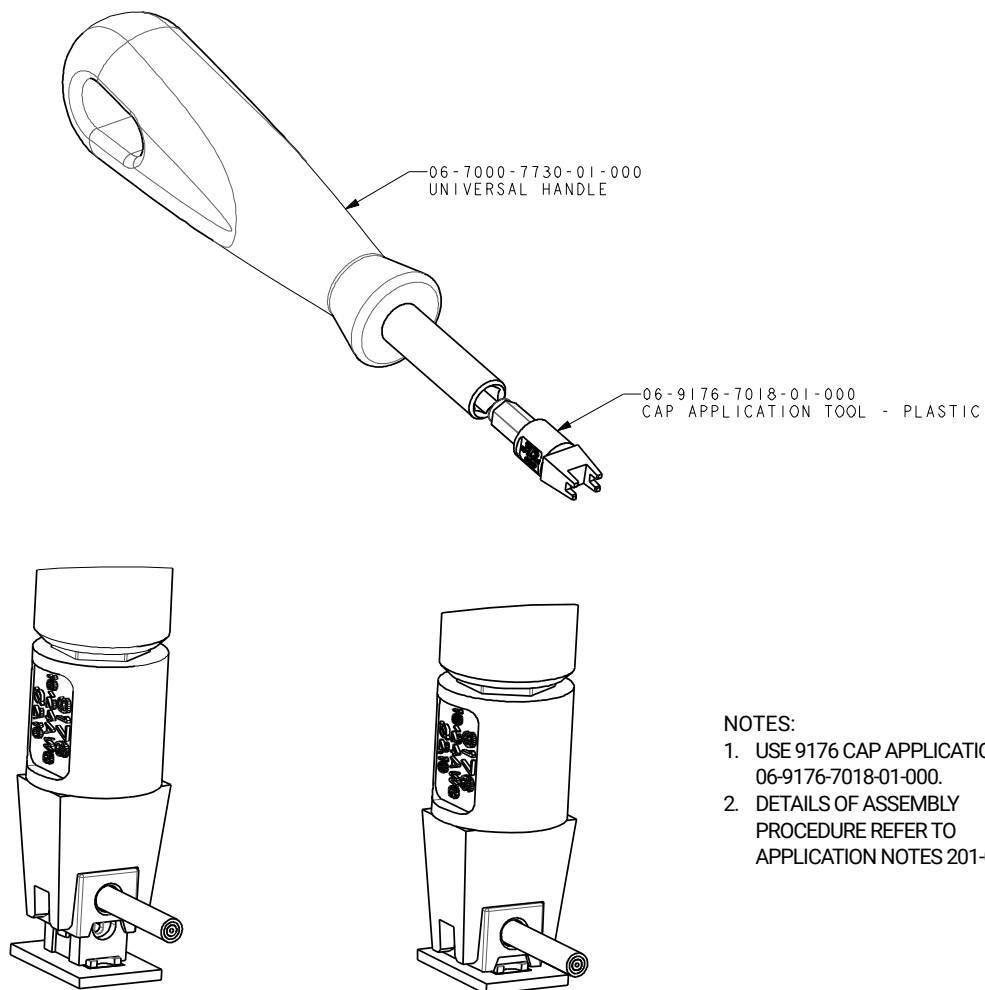

#### NOTES:

1. USE 9176 CAP APPLICATION TOOL  
06-9176-7018-01-000.
2. DETAILS OF ASSEMBLY  
PROCEDURE REFER TO  
APPLICATION NOTES 201-01-131.



**FOLLOW US:**     

VISIT US AT [WWW.KYOCERA-AVX.COM](http://WWW.KYOCERA-AVX.COM) 

A light gray world map is centered in the background of the lower half of the page. Overlaid on the map are five regional labels with their respective phone numbers. The labels are: North America (top left), Central America (bottom left), Europe (center), Asia (top right), and Japan (bottom right).

**North America**

Tel: +1 864-967-2150

**Europe**

Tel: +44 1276-697000

**Asia**

Tel: +65 6286-7555

**Central America**

Tel: +55 11-46881960

**Japan**

Tel: +81 740-321250