

REVISIONS				
REV	ECO	DESCRIPTION	DATE	BY APPR
A1	-	RELEASED DRAWING	Jul-16-18	Flan Tommy

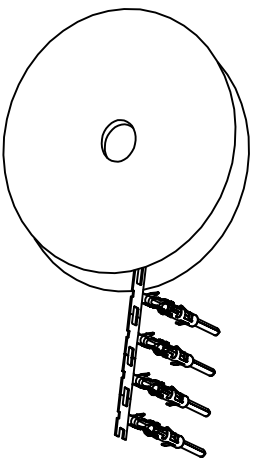

CONTACT ORIENTATION ON ROLL(3000PCS/COIL)

NOTES : (UNLESS OTHERWISE SPECIFIED)
 1. MATERIAL :

- 1.1. CONTACT BODY : COPPER ALLOY.
- 1.2. OUTER SPRING : STAINLESS STEEL.

2. SPECIFICATIONS :

- 2.1 CURRENT RATING : 13A MAX.
- 2.2 TERMINATION TYPE : CRIMPING.
- 2.3 WIRE RANGE : 22~20AWG.
- 2.4 WIRE INSULATION DIA(MAX) : ϕ 2.5mm.

3. RoHS COMPLIANT.

4. ALL DIMENSIONS ARE FOR REFERENCE USE ONLY.

5. AVAILABLE TOOLS :

- 5.1 HAND CRIMPER : MFX-3954.
- 5.2 CRIMP APPLICATOR : MFX-3957.
- 5.3 EXTRACTION TOOL : QXRT16.

P/N	CONTACT PLATING(MATING AREA)
SP20M2T	TIN PLATING OVER NICKEL.
SP20M2N	NICKEL PLATING OVER COPPERIZE.
SP20M2F	GOLD FLASH PLATING OVER NICKEL.
SP20M2G5	5 μ "GOLD PLATING OVER NICKEL.
SP20M2G10	10 μ "GOLD PLATING OVER NICKEL.
SP20M2G15	15 μ "GOLD PLATING OVER NICKEL.
SP20M2G30	30 μ "GOLD PLATING OVER NICKEL.

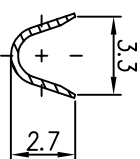
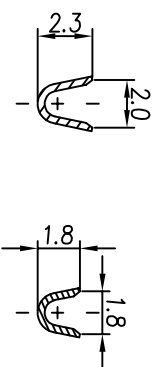
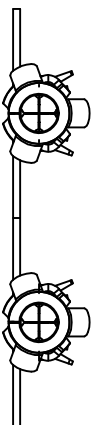
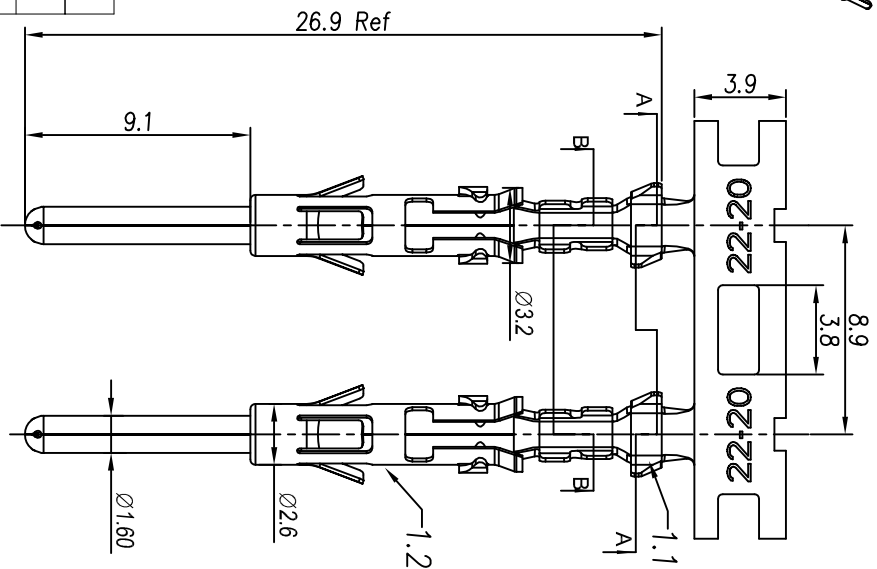

SECTION A-A

SECTION B-B

QUANTITY	PART NUMBER	DESCRIPTION	ITEM

UNLESS OTHERWISE SPECIFIED			
1) All dimensions are in millimeters.	1) 所有尺寸均以毫米为单位。	DATE	DATE
2) Tolerances are as follows: 0.10mm, 0.05mm, 0.02mm, 0.01mm.	2) 公差如下: 0.10mm, 0.05mm, 0.02mm, 0.01mm.	DESIGNED BY	DESIGNED BY
3) Note reference = Δ	3) 注意参考 = Δ	ENGINEER	ENGINEER
		APPROVAL	APPROVAL
		CUSTOMER	CUSTOMER

MATERIAL SPECIFICATIONS			
PROCESS SPECIFICATIONS			
NEXT ASSY:			

MATERIAL SPECIFICATIONS			
PROCESS SPECIFICATIONS			
NEXT ASSY:			

MATERIAL SPECIFICATIONS			
PROCESS SPECIFICATIONS			
NEXT ASSY:			

MATERIAL SPECIFICATIONS			
PROCESS SPECIFICATIONS			
NEXT ASSY:			

MATERIAL SPECIFICATIONS			
PROCESS SPECIFICATIONS			
NEXT ASSY:			

MATERIAL SPECIFICATIONS			
PROCESS SPECIFICATIONS			
NEXT ASSY:			

MATERIAL SPECIFICATIONS			
PROCESS SPECIFICATIONS			
NEXT ASSY:			

MATERIAL SPECIFICATIONS			
PROCESS SPECIFICATIONS			
NEXT ASSY:			

MATERIAL SPECIFICATIONS			
PROCESS SPECIFICATIONS			
NEXT ASSY:			

MATERIAL SPECIFICATIONS			
PROCESS SPECIFICATIONS			
NEXT ASSY:			

MATERIAL SPECIFICATIONS			
PROCESS SPECIFICATIONS			
NEXT ASSY:			

MATERIAL SPECIFICATIONS			
PROCESS SPECIFICATIONS			
NEXT ASSY:			

MATERIAL SPECIFICATIONS			
PROCESS SPECIFICATIONS			
NEXT ASSY:			

MATERIAL SPECIFICATIONS			
PROCESS SPECIFICATIONS			
NEXT ASSY:			

MATERIAL SPECIFICATIONS			
PROCESS SPECIFICATIONS			
NEXT ASSY:			

MATERIAL SPECIFICATIONS			
PROCESS SPECIFICATIONS			
NEXT ASSY:			

MATERIAL SPECIFICATIONS			
PROCESS SPECIFICATIONS			
NEXT ASSY:			

MATERIAL SPECIFICATIONS			
PROCESS SPECIFICATIONS			
NEXT ASSY:			

MATERIAL SPECIFICATIONS			
PROCESS SPECIFICATIONS			
NEXT ASSY:			

MATERIAL SPECIFICATIONS			
PROCESS SPECIFICATIONS			
NEXT ASSY:			

MATERIAL SPECIFICATIONS			
PROCESS SPECIFICATIONS			
NEXT ASSY:			

MATERIAL SPECIFICATIONS			
PROCESS SPECIFICATIONS			
NEXT ASSY:			

MATERIAL SPECIFICATIONS			
PROCESS SPECIFICATIONS			
NEXT ASSY:			

MATERIAL SPECIFICATIONS			
PROCESS SPECIFICATIONS			
NEXT ASSY:			

MATERIAL SPECIFICATIONS			
PROCESS SPECIFICATIONS			
NEXT ASSY:			

MATERIAL SPECIFICATIONS			
PROCESS SPECIFICATIONS			
NEXT ASSY:			

MATERIAL SPECIFICATIONS			
PROCESS SPECIFICATIONS			
NEXT ASSY:			

MATERIAL SPECIFICATIONS			
PROCESS SPECIFICATIONS			
NEXT ASSY:			

MATERIAL SPECIFICATIONS			
PROCESS SPECIFICATIONS			
NEXT ASSY:			

MATERIAL SPECIFICATIONS			
PROCESS SPECIFICATIONS			
NEXT ASSY:			

MATERIAL SPECIFICATIONS			
PROCESS SPECIFICATIONS			
NEXT ASSY:			

MATERIAL SPECIFICATIONS			
PROCESS SPECIFICATIONS			
NEXT ASSY:			

MATERIAL SPECIFICATIONS			
PROCESS SPECIFICATIONS			
NEXT ASSY:			

MATERIAL SPECIFICATIONS			
PROCESS SPECIFICATIONS			
NEXT ASSY:			

MATERIAL SPECIFICATIONS			
PROCESS SPECIFICATIONS			
NEXT ASSY:			

MATERIAL SPECIFICATIONS			
PROCESS SPECIFICATIONS			
NEXT ASSY:			

MATERIAL SPECIFICATIONS			
PROCESS SPECIFICATIONS			
NEXT ASSY:			

MATERIAL SPECIFICATIONS			
PROCESS SPECIFICATIONS			
NEXT ASSY:			

MATERIAL SPECIFICATIONS			
PROCESS SPECIFICATIONS			
NEXT ASSY:			

MATERIAL SPECIFICATIONS			
PROCESS SPECIFICATIONS			
NEXT ASSY:			

MATERIAL SPECIFICATIONS			
PROCESS SPECIFICATIONS			
NEXT ASSY:			

MATERIAL SPECIFICATIONS			
PROCESS SPECIFICATIONS			
NEXT ASSY:			

MATERIAL SPECIFICATIONS			
PROCESS SPECIFICATIONS			
NEXT ASSY:			

MATERIAL SPECIFICATIONS			
PROCESS SPECIFICATIONS			
NEXT ASSY:			

MATERIAL SPECIFICATIONS			
PROCESS SPECIFICATIONS			
NEXT ASSY:			

MATERIAL SPECIFICATIONS			
PROCESS SPECIFICATIONS			
NEXT ASSY:			

MATERIAL SPECIFICATIONS			
PROCESS SPECIFICATIONS			
NEXT ASSY:			

MATERIAL SPECIFICATIONS			
PROCESS SPECIFICATIONS			
NEXT ASSY:			

MATERIAL SPECIFICATIONS			
PROCESS SPECIFICATIONS			
NEXT ASSY:			

MATERIAL SPECIFICATIONS			
PROCESS SPECIFICATIONS			
NEXT ASSY:			

MATERIAL SPECIFICATIONS			
PROCESS SPECIFICATIONS			
NEXT ASSY:			

MATERIAL SPECIFICATIONS			
PROCESS SPECIFICATIONS			
NEXT ASSY:			

MATERIAL SPECIFICATIONS			
PROCESS SPECIFICATIONS			
NEXT ASSY:			

MATERIAL SPECIFICATIONS			
PROCESS SPECIFICATIONS			
NEXT ASSY:			

MATERIAL SPECIFICATIONS			
PROCESS SPECIFICATIONS			
NEXT ASSY:			

MATERIAL SPECIFICATIONS			
PROCESS SPECIFICATIONS			
NEXT ASSY:			

MATERIAL SPECIFICATIONS			
PROCESS SPECIFICATIONS			
NEXT ASSY:			

MATERIAL SPECIFICATIONS			
PROCESS SPECIFICATIONS			
NEXT ASSY:			

MATERIAL SPECIFICATIONS			
PROCESS SPECIFICATIONS			
NEXT ASSY:			

MATERIAL SPECIFICATIONS			
PROCESS SPECIFICATIONS			
NEXT ASSY:			

MATERIAL SPECIFICATIONS			
PROCESS SPECIFICATIONS			
NEXT ASSY:			

MATERIAL SPECIFICATIONS			
PROCESS SPECIFICATIONS			
NEXT ASSY:			

MATERIAL SPECIFICATIONS			
PROCESS SPECIFICATIONS			
NEXT ASSY:			

MATERIAL SPECIFICATIONS			
PROCESS SPECIFICATIONS			
NEXT ASSY:			

MATERIAL SPECIFICATIONS			
PROCESS SPECIFICATIONS			
NEXT ASSY:			

MATERIAL SPECIFICATIONS			
PROCESS SPECIFICATIONS			
NEXT ASSY:			

MATERIAL SPECIFICATIONS			
PROCESS SPECIFICATIONS			
NEXT ASSY:			

MATERIAL SPECIFICATIONS			
PROCESS SPECIFICATIONS			
NEXT ASSY:			

MATERIAL SPECIFICATIONS			
PROCESS SPECIFICATIONS			
NEXT ASSY:			

MATERIAL SPECIFICATIONS			
PROCESS SPECIFICATIONS			
NEXT ASSY:			

MATERIAL SPECIFICATIONS			
PROCESS SPECIFICATIONS			
NEXT ASSY:			

MATERIAL SPECIFICATIONS			
PROCESS SPECIFICATIONS			
NEXT ASSY:			

MATERIAL SPECIFICATIONS			
PROCESS SPECIFICATIONS			
NEXT ASSY:			

MATERIAL SPECIFICATIONS			
PROCESS SPECIFICATIONS			
NEXT ASSY:			

MATERIAL SPECIFICATIONS			
PROCESS SPECIFICATIONS			
NEXT ASSY:			

MATERIAL SPECIFICATIONS			
PROCESS SPECIFICATIONS			
NEXT ASSY:			

MATERIAL SPECIFICATIONS			
PROCESS SPECIFICATIONS			
NEXT ASSY:			

MATERIAL SPECIFICATIONS			
PROCESS SPECIFICATIONS			
NEXT ASSY:			

MATERIAL SPECIFICATIONS			
PROCESS SPECIFICATIONS			
NEXT ASSY:			

MATERIAL SPECIFICATIONS			
PROCESS SPECIFICATIONS			
NEXT ASSY:			

MATERIAL SPECIFICATIONS			
PROCESS SPECIFICATIONS			
NEXT ASSY:			

MATERIAL SPECIFICATIONS			
PROCESS SPECIFICATIONS			
NEXT ASSY:			

MATERIAL SPECIFICATIONS			
PROCESS SPECIFICATIONS			
NEXT ASSY:			

MATERIAL SPECIFICATIONS			
PROCESS SPECIFICATIONS			
NEXT ASSY:			

MATERIAL SPECIFICATIONS			
PROCESS SPECIFICATIONS			
NEXT ASSY:			

MATERIAL SPECIFICATIONS			
PROCESS SPECIFICATIONS			
NEXT ASSY:			

MATERIAL SPECIFICATIONS			
PROCESS SPECIFICATIONS			
NEXT ASSY:			

MATERIAL SPECIFICATIONS			
PROCESS SPECIFICATIONS			
NEXT ASSY:			

MATERIAL SPECIFICATIONS			
PROCESS SPECIFICATIONS			
NEXT ASSY:			

MATERIAL SPECIFICATIONS			
PROCESS SPECIFICATIONS			
NEXT ASSY:			

MATERIAL SPECIFICATIONS			
PROCESS SPECIFICATIONS			
NEXT ASSY:			

MATERIAL SPECIFICATIONS			
PROCESS SPECIFICATIONS			
NEXT ASSY:			