

SOT24-001

Time-of-Flight Sensor

Datasheet



Index

1. General description	4
1.1 Technical specifications	5
1.2 System block diagram	5
2. Mechanical characteristics	6
2.1 Pin definition	6
2.2 Module dimensions	7
3. Electrical characteristics	7
3.1 Absolute maximum ratings	7
3.2 Recommended operating conditions	8
3.3 ESD performance	8
3.4 Digital input and output	8
4. Typical ranging characteristics	9
5. Functional description	10
5.1 I ² C Control interface	10
5.2 Timing	13
5.2.1 Ranging acquisition timing	13
5.2.2 Reset pin and power-up timing	14
5.3 Current consumption	14
5.4 Typical optical characteristics	14
6. Application information	15
6.1 Application schematic	15
6.2 PCB layout	16
6.3 PCB pad layout	16
7. Soldering and storage	17
7.1 Manufacturing and soldering	17
7.2 Storage information	18
8. Reliability Test	19
9. Package Specifications	19
9.1 Tape Specifications	19
9.2 Reel Specification	20
9.3 The content of Box	20
10. Laser eye safety	21
11. Acronyms and abbreviations	21

1. General description

The SOT24-001 is a direct Time-of-Flight (dToF) sensor module within a single modular package which integrates a single photon avalanche diode (SPAD) sensor and a VCSEL emitter. This sensor provides a compact solution for precise ranging of an object irrespective of the color, reflectivity and texture of the object. The SOT24-001 can achieve an accurate distance measurement up to 4 meters and a high ranging speed up to 90 Hz.

A built-in histogram-based algorithm with cover glass calibration and compensation for smudges is implanted in the sensor for high reliability operations. Class 1 eye safety is featured by sub-nanosecond optical laser pulse and special eye safety control circuit. The sensor can be used for distance measurement in the outdoor sunlight environment since the ambient light noise is minimized through narrow band optical filter and built-in sunlight rejection algorithm. Measurement data and system configuration are transferred via I²C fast-mode communication interface. The sensor is easy for system integration as a single power supply is used and no additional optics is needed.

Features

- Fully integrated SIP module
 - Size: 4.4 mm × 2.4 mm × 0.975 mm
 - 940 nm VCSEL emitter
- Methodology
 - Direct time-of-flight measurement
 - Histogram based algorithm
 - Reference SPAD
- Distance measurement
 - Range: up to 4 m
 - Ranging rate: up to 90 Hz
 - Measurement accuracy: ±4%
 - Distance and confidence level reported
- Optics
 - Class 1 laser device
- On-chip compensation
 - Ambient light rejection
 - Cover glass calibration
 - Dynamic compensation for smudge on glass
- Easy integration
 - Single power supply
 - SIP package design
 - I²C interface

Applications

- Distance measurement for camera autofocus (LDAF)
- Proximity detection
- Collisions avoidance
- 1D gesture recognition
- Object detection supporting low-power system operation

1.1 Technical specifications

Table 1: Technical specifications

Parameter	Value
Package	LGA 12
Size	4.4 mm × 2.4 mm × 0.975 mm
Operating voltage	3.2 V ~ 3.6 V
Operating temperature	-20°C ~ 70°C
Infrared emitter	940 nm
I ² C interface	Up to 1 MHz Address: 0xd8

1.2 System block diagram

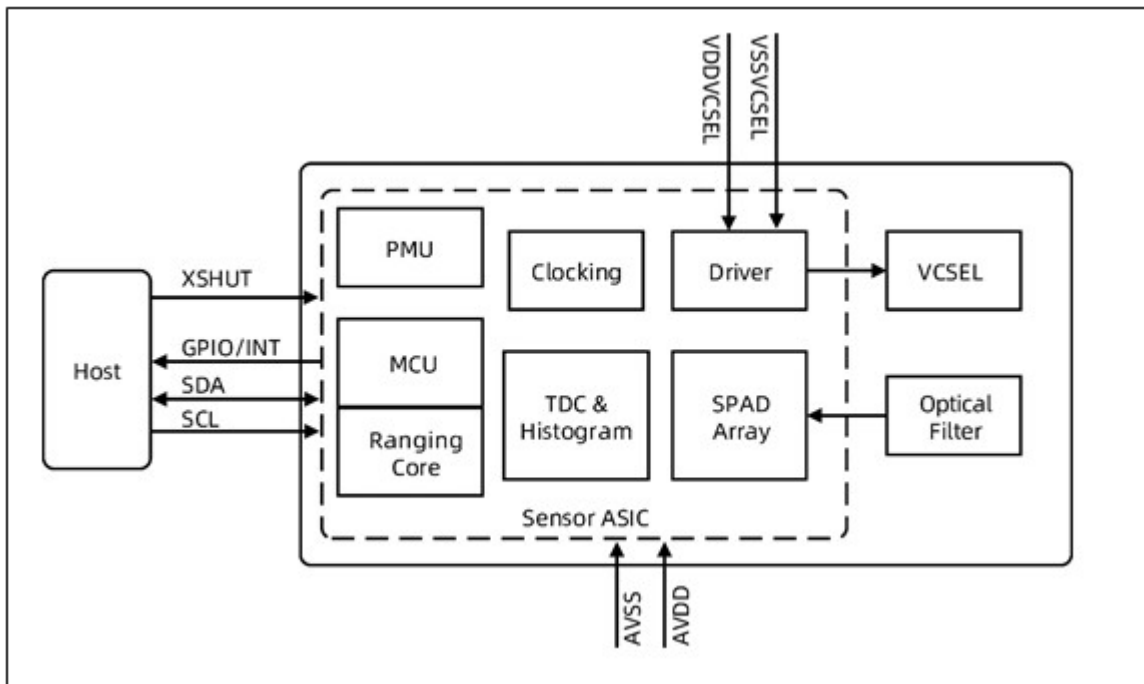

Figure 1: System block diagram

2. Mechanical characteristics

2.1 Pin definition

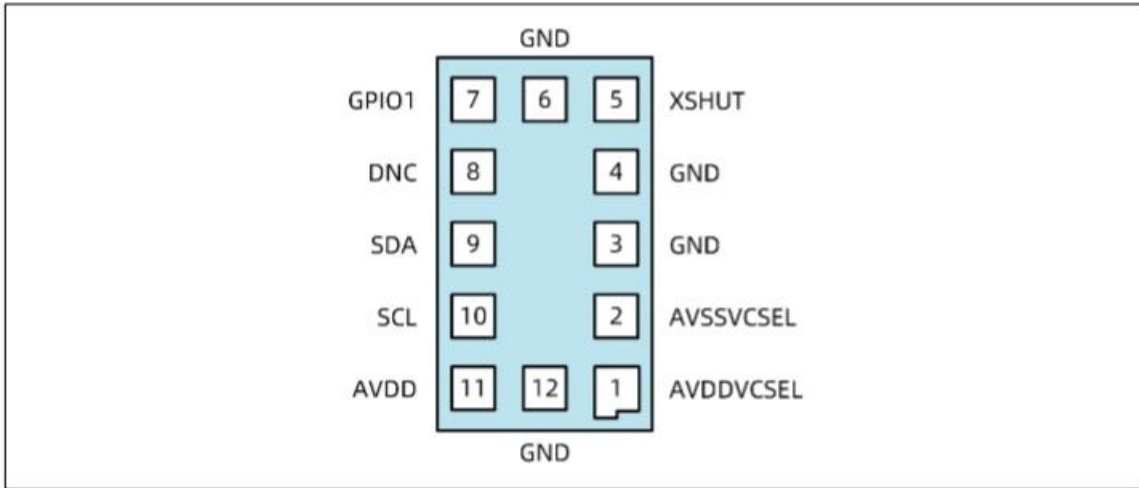

Figure 2: Pin out diagram (bottom view)

Table 2: Pin definition

Pin No.	Pin name	Signal type	Description
1	AVDDVCSEL	Supply	3.2 V ~ 3.6 V DC
2	AVSSVCSEL	Ground	To be connected to ground
3	GND	Ground	To be connected to ground
4	GND	Ground	To be connected to ground
5	XSHUT	Digital input	Hardware reset pin, active low
6	GND	Ground	To be connected to ground
7	GPIO1	Digital output	Interrupt output, open drain output
8	DNC	-	Leave this pin floating
9	SDA	Digital input/output	I ² C serial data
10	SCL	Digital input	I ² C serial clock input
11	AVDD	Supply	3.2 V ~ 3.6 V DC
12	GND	Ground	To be connected to ground

2.2 Module dimensions

The SOT24-001 is a 12 Pin LGA package with plastic lid. Its dimensions are 4.4mm (± 0.05 mm) x 2.4mm (± 0.05 mm) x 0.975mm (± 0.075 mm). Tolerance is ± 0.05 mm unless otherwise specified.

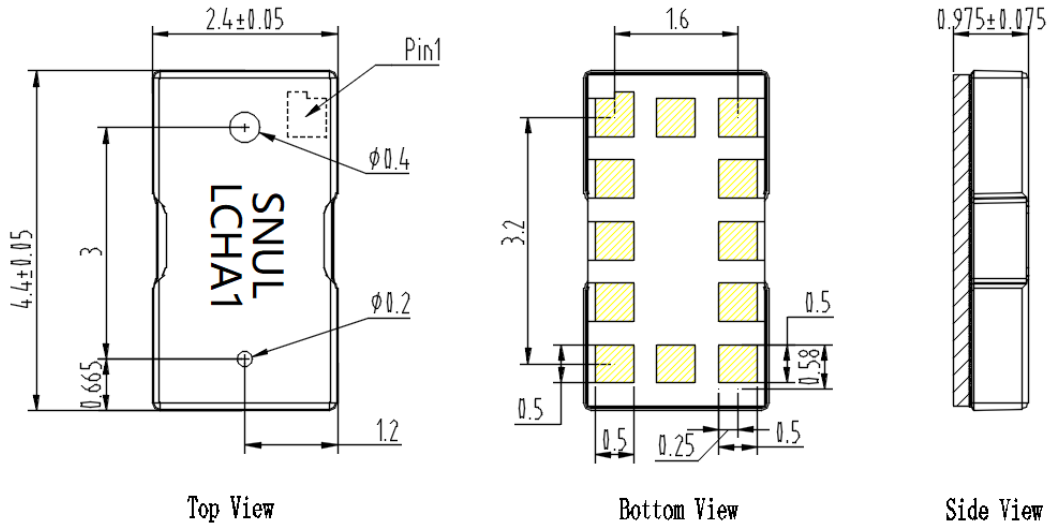

Figure 3: SOT24-001 outline dimension

3. Electrical characteristics

3.1 Absolute maximum ratings

Table 3: Absolute maximum ratings ¹⁾

Parameter	Min.	Typ.	Max.	Unit
AVDD	-0.3	-	3.6	V
SCL, SDA, XSHUT and GPIO	-0.3	-	3.6	V
Storage temperature	-40	-	85	°C
Relative humidity (non- condensing)	-	-	85	%
Moisture sensitivity level	MSL.3 ²⁾			-

1) Stresses beyond those listed in Table 3 may cause permanent damage to the device. These are stress ratings only, and functional operation of the device at these or any other conditions beyond those indicated in Section 5 Electrical characteristics is not implied. Exposure to absolute maximum rating conditions for extended periods may affect device reliability.

2) Represents a maximum floor life time of 168 h with ambient temperature < 30°C and relative humidity < 60%.

3.2 Recommended operating conditions

Table 4: Recommended operating conditions

Parameter	Min.	Typ.	Max.	Unit
Voltage (AVDD)	3.2	3.3	3.6	V
IO (IOVDD) 1.8V mode	1.7	1.8	1.9	V
IO (IOVDD) 3.3V mode	3.0	3.3	3.6	V
Temperature (normal operating)	-20	-	70	°C

3.3 ESD performance

The SOT24-001 is compliant with the ESD values presented in the table below.

Table 5: ESD performance

Parameter	Specification	Condition
HBM (Human Body Model)	JS-001-2017	±2000 V
CDM (Charged Device Model)	JS-002-2018	±500 V

3.4 Digital input and output

Table 6: Digital input and output

Symbol	Parameter	Min.	Typ.	Max.	Unit
Interrupt pin (GPIO)					
V _{IL}	Low level input voltage	-	-	0.3xIOVDD	V
V _{IH}	High level input voltage	0.7xIOVDD	-	-	V
V _{OL}	Low level output voltage (I _{OUT} = 4 mA)	-	-	0.4	V
V _{OH}	High level output voltage (I _{OUT} = 4 mA)	IOVDD-0.4	-	-	V
FGPIO	Operating frequency (C _{LOAD} = 20 pF)	68	75	83	MHz
I ² C interface (SDA/SCL)					
V _{IL}	Low level input voltage	-	-	0.3xIOVDD	V
V _{IH}	High level input voltage	0.7xIOVDD	-	-	V
V _{OL}	Low level output voltage (I _{OUT} = 4 mA)	-	-	0.4	V
I _{IL/IH}	Leakage current ¹⁾	-	-	0.1	µA
	Leakage current ²⁾	-	-	1	µA

1) AVDD = 0 V

2) AVDD = 3.3 V; I/O Voltage = 1.8 V

4. Typical ranging characteristics

To achieve the performance described as follows, a calibration of the algorithm needs to be performed. The calibration test shall be done in a space without any IR light and no target within 60 cm in field of view of the sensor. The SOT24-001 generates a calibration data set which is permanently stored on the host. Every time the SOT24-001 is powered on, the calibration data set will be sent via I²C interface to the SOT24-001 prior to execution of any algorithms (commands=0x0A).

The following operating characteristics are measured with calibrated devices with full FoV covered and no cover glass, and the integration times setting is 131072.

Table 7: Ranging characteristics¹⁾

Parameter	Condition	Min.	Typ.	Max.	Unit
Maximum distance detection, 1 m x 1 m object	350 lux fluorescent on object, 88% white card	-	4000	-	mm
	350 lux fluorescent on object, 18% grey card	-	2500	-	mm
	350 lux fluorescent on object, 10% black card	-	2000	-	mm
	700 lux halogen light on object 2), 88% white card	-	1500	-	mm
	700 lux halogen light on object 2), 18% grey card	-	1200	-	mm
	14000 lux halogen light on object 3), 18% grey card	-	480	-	mm
Minimum distance detection, 18% grey card, 1 m x 1 m			25	-	mm
Accuracy	Object distance \geq 250 mm	-	± 4	-	%
	25 mm \leq object distance < 250 mm	-	± 10	-	mm

1) Maximum detection distance threshold: confidence level ≥ 30 , detection rate 90%.

2) 700 lux halogen light represents 5k lux sunlight equivalent; light on object only.

3) 14000 lux halogen light represents 100 k lux sunlight equivalent; light on object only.

5. Functional description

5.1 I²C Control interface

The I²C interface uses two signals: the serial data line (SDA) and serial clock line (SCL). Each device connected to the bus uses a unique address and a simple master/slave relationships exists. The SOT24-001 provides a standard I²C interface which supports slave mode with the device address 0xd8 (0xd8 for Write, and 0xd9 for Read). 8-bit address and 8-bit data are used to configure the registers.

Both SDA and SCL lines are connected to a positive supply voltage using pull up resistors located on the host. Lines are only actively driven low. A high condition occurs when the lines float and the pull up resistors pull them up. When no data are transmitted both lines are high.

Clock signal (SCL) generation is performed by the master device. The master device initiates data transfer. The I²C bus on the SOT24-001 has a maximum speed of 1 Mbps.

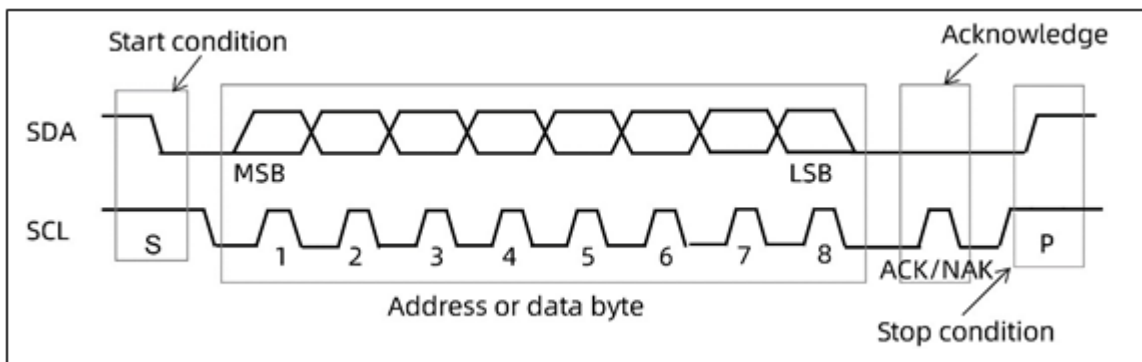

Figure 4: Data transfer protocol

Data is packed in 8-bit packets (bytes). During a write sequence, the data bytes are followed by an acknowledge bit ACK for SOT24-001 acknowledge; during a read sequence, the data bytes are followed by a negative acknowledge bit NAK for master acknowledge. The internal data are produced by sampling SDA at a rising edge of SCL. The external data must be stable during the high period of SCL. The exceptions to this are start (S) or stop (P) conditions when SDA falls or rises respectively, while SCL is high.

A message contains a series of bytes preceded by a start condition and followed by either a stop or repeated start (another start condition but without a preceding stop condition) followed by another message. The first byte contains the device address (0xd8) and also specifies the data direction. If the least significant bit is low (that is, 0xd8) the message is a master-write-to-the-slave. If the LSB is set (that is, 0xd9) then the message is a master-read-from-the-slave.

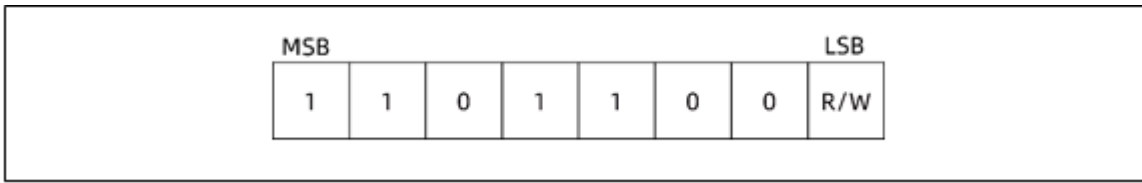

Figure 5: SOT24-001 I²C device address: 0xd8

All serial interface communications must begin with a start condition. The SOT24-001 module acknowledges the receipt of a valid address by driving the SDA wire low. The state of the read/write bit (LSB of the address byte) is stored and the next byte of data, sampled from SDA, can be interpreted. During a write sequence, the second byte received provides an 8-bit index which points to one of the internal 8-bit registers.

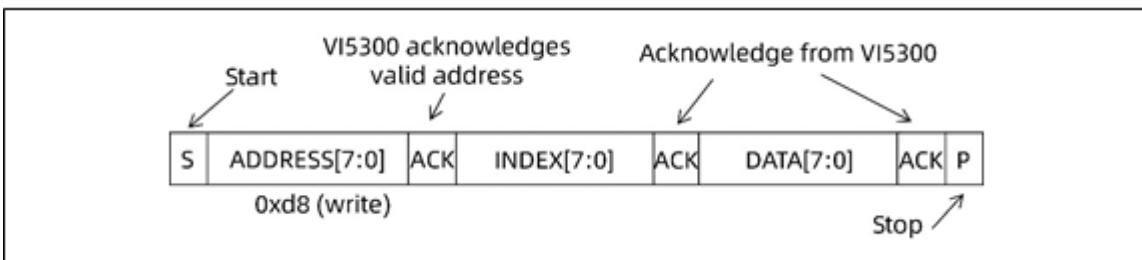

Figure 6: SOT24-001 data format (write)

As data is received by the slave, it is written bit-by-bit to a serial/parallel register. After each data byte has been received by the slave, an acknowledgement is generated, the data is then stored in the internal register addressed by the current index.

During a read message, the contents of the register addressed by the current index is read out in the byte following the device address byte. The contents of this register are parallel loaded into the serial/parallel register and clocked out of the device by the falling edge of SCL.

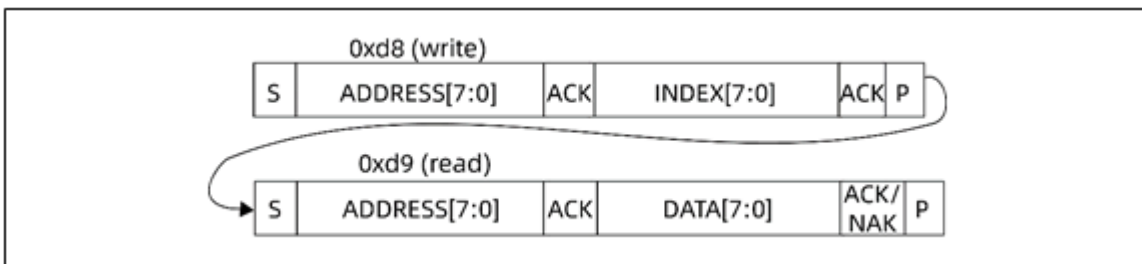

Figure 7: SOT24-001 data format (read)

During a read sequence, an acknowledgement is issued by SOT24-001 at the end of each byte. A message can only be terminated by the bus master, by issuing a negative acknowledge (that is, not pulling the SDA line low) after reading a complete byte during a read operation.

The interface also supports auto-increment indexing. After the first data byte has been transferred, the index is automatically incremented by 1. The master can therefore send data bytes continuously to the slave until the slave fails to provide an acknowledgement or the master terminates the write

communication with a stop condition. If the auto-increment feature is used the master does not have to send address indexes to accompany the data bytes.

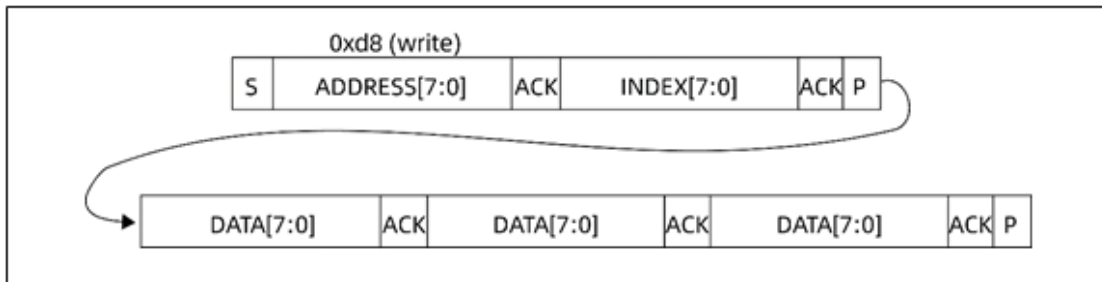

Figure 8: SOT24-001 data format (sequential write)

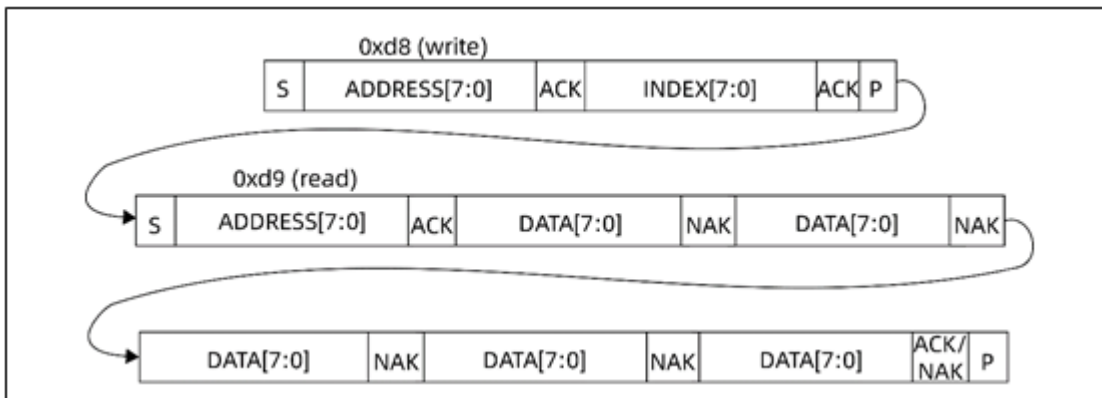

Figure 9: SOT24-001 data format (sequential read)

Please refer to Figure 10 for an explanation of the parameters used.

Table 8: I²C interface - timing characteristics

Symbol	Parameter	Min.	Typ.	Max.	Unit
F _{I2C}	Operating frequency	0	-	1	MHz
t _{LOW}	Clock pulse width low	0.5	-	-	μs
t _{HIGH}	Clock pulse width high	0.26	-	-	
t _{SP}	Pulse width of spikes which are suppressed by the input filter	-	-	10	ns
t _{BUF}	Bus free time between transmissions	0.5	-	-	μs
t _{HD.STA}	Start hold time	0.26	-	-	μs
t _{SU.STA}	Start set-up time	0.26	-	-	
t _{HD.DAT}	Data in hold time	0	-	-	
t _{SU.DAT}	Data in set-up time	100	-	-	
t _R	SCL/SDA rise time	-	-	120	ns
t _F	SCL/SDA fall time	-	-	120	
t _{SU.STO}	Stop set-up time	0.26	-	-	μs
C _{i/o}	Input/output capacitance (SDA)	-	-	10	
C _{in}	Input capacitance (SCL)	-	-	10	pF
C _L	Load capacitance	-	-	200	

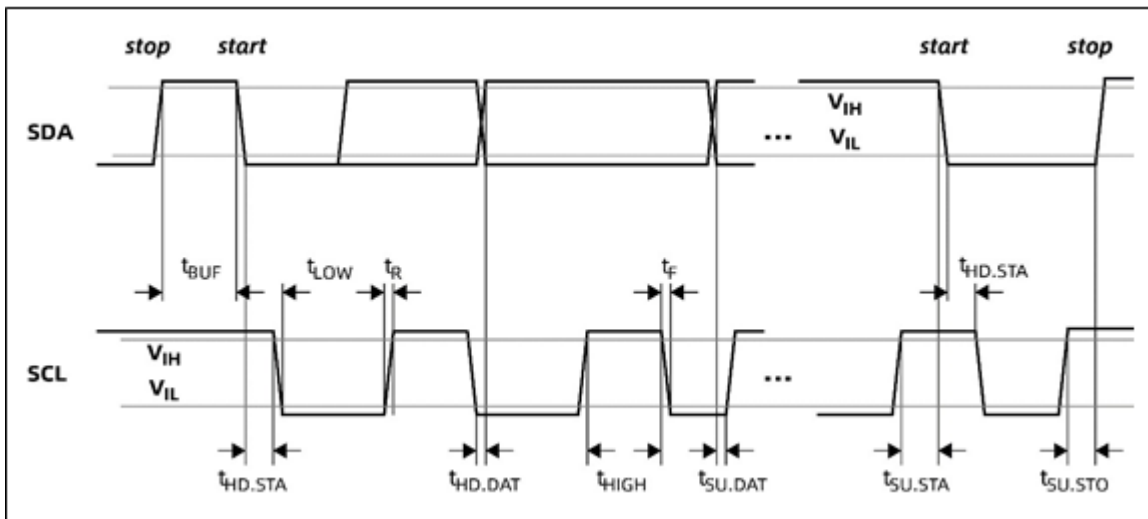

Figure 10: I²C timing characteristics (All timings are measured from either V_{IL} or V_{IH})

5.2 Timing

5.2.1 Ranging acquisition timing

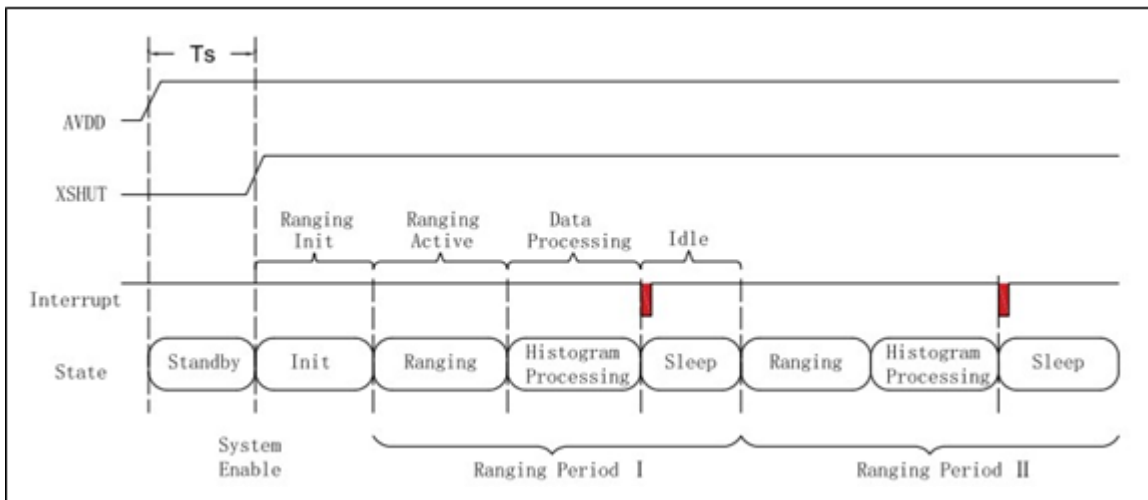

Figure 11: Ranging timing diagram

Table 9: Ranging acquisition timing

Parameter	Min.	Typ.	Max.	Unit
Ranging Time Default Setting ¹⁾	-	19.2	-	ms
Ranging Init (including electrical calibration) ²⁾	-	8	-	ms
Ranging Period ³⁾	11	33	-	ms

1) Varies with operational mode;

2) Only done on startup and if temperature changed from last calibration;

3) Typical frame rate is 30 fps and is programmable by the interface.

5.2.2 Reset pin and power-up timing

Table 10: Reset pin and power-up timing

Parameter	Min.	Typ.	Max.	Unit
Power On (Boot Time)	-	5	-	ms
Enable high to ready for measurement ¹⁾	-	2	-	ms
Standby to Active Time	-	1	-	ms
Active to Standby Time	-	1	-	ms
Enable Low to Power Down Time	-	1	-	ms

1) Does not include calibration data download time.

5.3 Current consumption

The following table shows the typical values of each power supply of the product in normal working mode.

Table 11: Current consumption

Parameter	Min.	Typ.	Max.	Unit
HW standby ¹⁾	-	-	1	μA
SW standby ²⁾ IOVDD 1.8V	6	8	20	μA
SW standby ²⁾ IOVDD 3.3V	6	7	10	μA
Active ranging average consumption ³⁾	14	16	20	mA

1) AVDD 3.2 V, XSHUT is low;

2) AVDD 3.2 V, XSHUT is high, and I²C interface is active;

3) 65536 x 2 integrations at 30 fps.

5.4 Typical optical characteristics

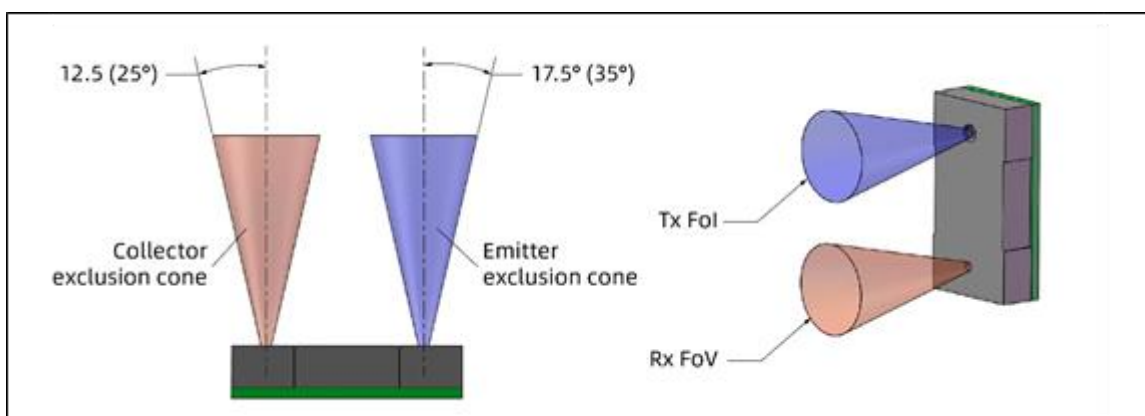

Figure 12: SOT24-001 Fol/FoV

VCSEL Field of Illumination (Fol):

- 35° considering a beam within the Tx exclusion cone
- 25° considering a beam with $1/e^2$ signal from maximum

Filter Characteristics:

- FWHM 45 nm
- Passband center frequency 940 nm

6. Application information

6.1 Application schematic

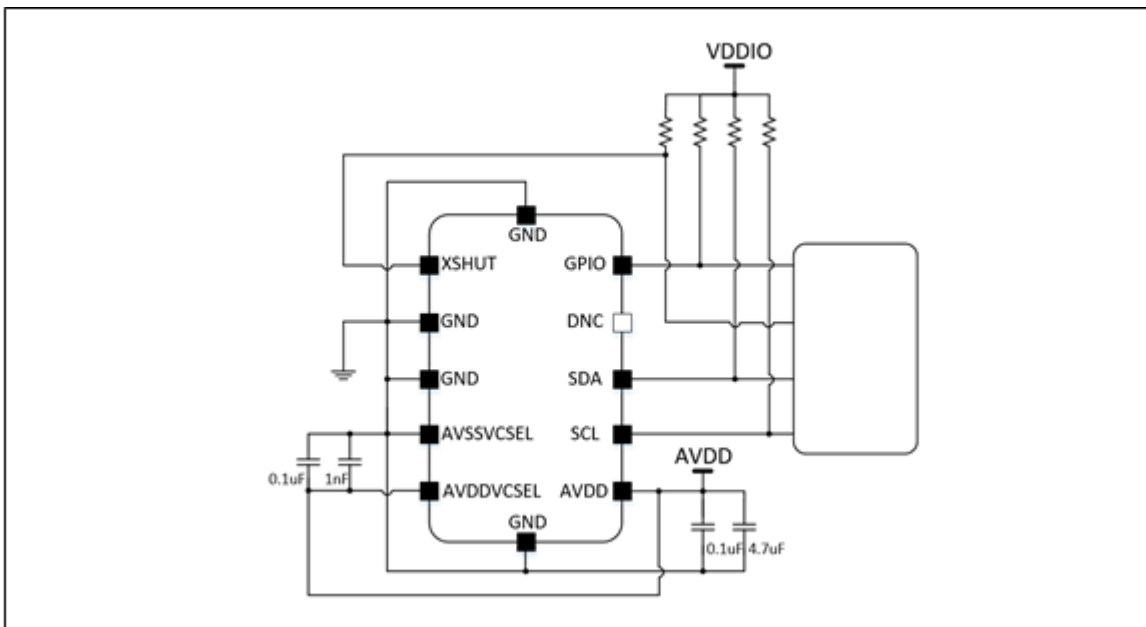

Figure 13: SOT24-001 schematic

Note:

- Capacitors on external power supply AVDD should be placed as close as possible to the AVDDVCSEL and AVSSVCSEL pins of SOT24-001.
- For external pull-up resistor values, please refer to I²C-bus specification. Pull-ups are typically fitted only once per bus, near the HOST.
Pull-up resistors of 1 kΩ to 1.5 kΩ are recommended for 1MHz I²C clock with 3.3 V AVDD.
- XSHUT pin must always be driven to avoid leakage current. Pull-up is needed if the host state is unknown.
Recommended value of XSHUT and GPIO pull up resistors is 10 kΩ.

6.2 PCB layout

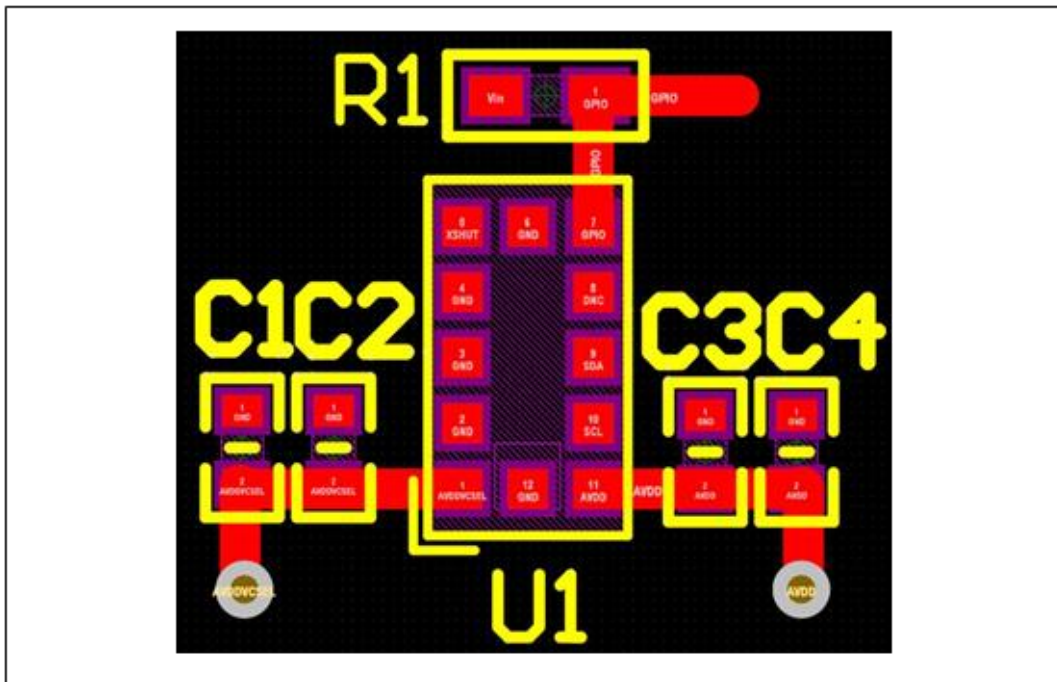

Figure 14: Recommended PCB layout

Recommended capacitance for C1 is 100nF and for C2 is 1nF. C1 and C2 should be placed as close to AVDDVCSEL pin as possible. Recommended capacitance for C3 is 0.1µF and for C4 is 4.7µF. C3 and C4 should be placed as close to AVDD pin as possible.

6.3 PCB pad layout

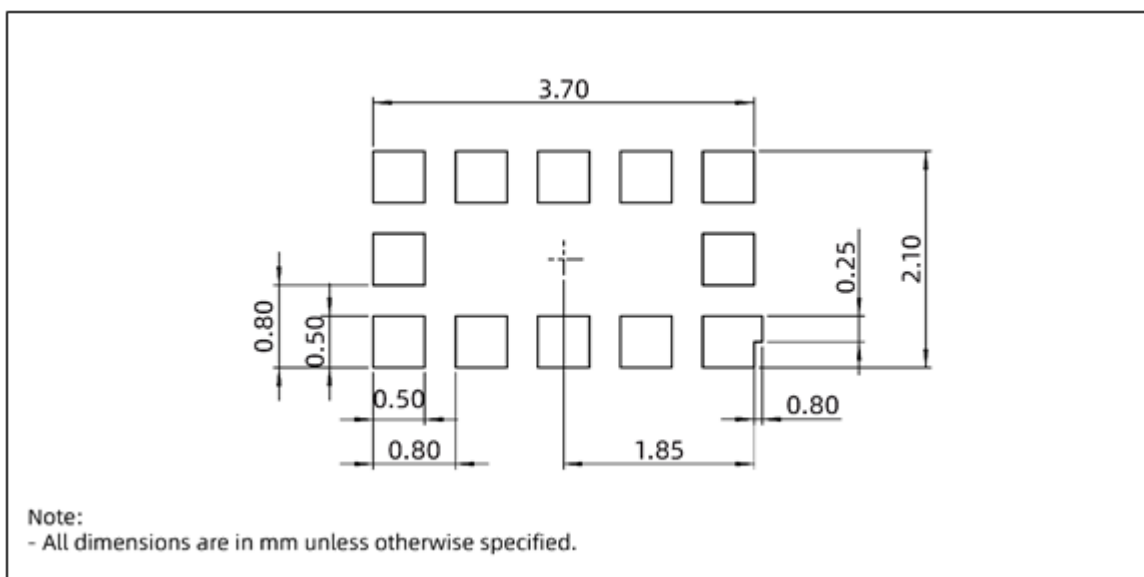

Figure 15: PCB footprint (top view)

7. Soldering and storage

7.1 Manufacturing and soldering

It is suggested that the peak reflow temperature is 240°C ~ 260°C and the absolute maximum reflow temperature is 260°C. The recommended reflow soldering thermal profile (lead-free reflow soldering) and related parameters are shown below:

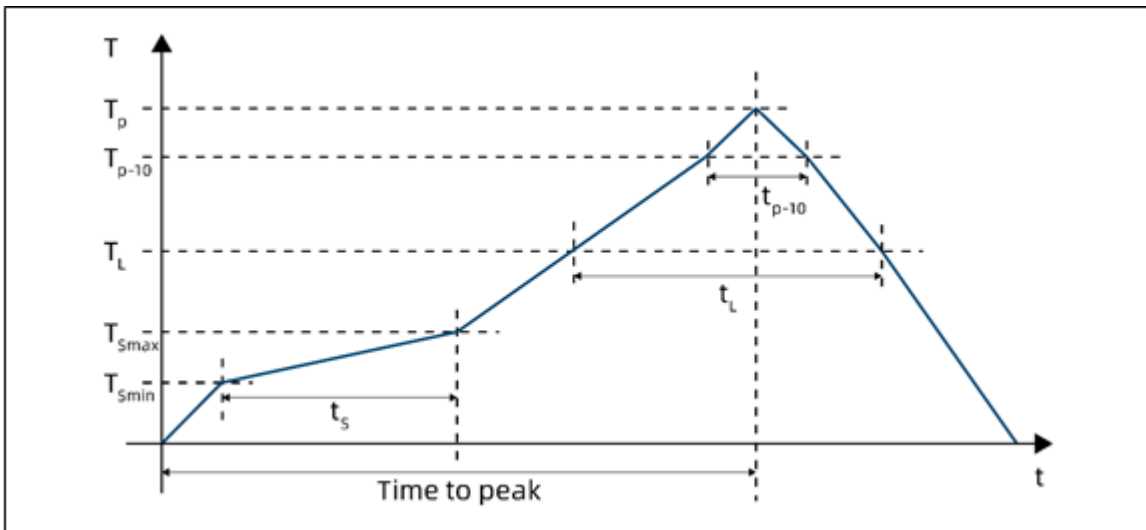

Figure 16: Recommended reflow soldering thermal profile

Table 13: Recommended thermal profile parameters

Parameter	Recomm. value	Max. value	Unit
Minimum temperature (T_{Smin})	130	150	°C
Maximum temperature (T_{Smax})	200	200	°C
Time t_s (T_{Smin} to T_{Smax})	90-110	60 - 120	s
Temperature (T_L)	217	217	°C
Time (t_L)	55-65	55 - 65	s
Ramp up	+2	+3	°C/s
Temperature (T_{p-10})	-	250	°C
Time (t_{p-10})	-	10	s
Ramp up	-	+3	°C/s
Peak temperature (T_p)	240	260 max.	°C
Time to peak	300	300	s
Ramp down (peak to T_L)	-4	-6	°C/s

Note:

- Temperature mentioned in the table above is measured at the top of the device package.
- The component should be limited to a maximum of 3 passes through this solder profile.

7.2 Storage information

The SOT24-001 is delivered in sealed moisture-barrier bags. It has been assigned a moisture sensitivity level of MSL 3. The following storage conditions must be noted:

Moisture Sensitivity

Optical characteristics of the device can be adversely affected during the soldering process by the release and vaporization of moisture that has been previously absorbed into the package.

To ensure the package contains the smallest amount of absorbed moisture possible, each device is baked prior to being dry packed for shipping. Devices are dry packed in a sealed aluminized envelope called a moisture-barrier bag with silica gel to protect them from ambient moisture during shipping, handling, and storage before use.

Shelf Life

The calculated shelf life of the device in an unopened moisture barrier bag is 12 months from the date code on the bag when stored under the following conditions:

- Shelf Life: 12 months
- Ambient temperature: $\leq 40^{\circ}\text{C}$
- Relative humidity: $\leq 90\%$

Re-baking of the devices will be required if the devices exceed the 12 months shelf life or the Humidity Indicator Card shows that the devices were exposed to conditions beyond the allowable moisture region.

Floor Life

The SOT24-001 is rated at MSL 3. As a result, the floor life of devices removed from the moisture barrier bag is 168 hours from the time the bag was opened, provided that the devices are stored under the following conditions:

- Floor Life: 168 hours
- Ambient temperature: $\leq 30^{\circ}\text{C}$
- Relative humidity: $\leq 60\%$

If the floor life or the temperature/humidity conditions have been exceeded, the devices must be re-baked prior to solder reflow or dry packing.

Re-baking Instructions

The re-baking conditions are as follows:

- 125 ± 5 degrees Celsius for 8 hours;
- The product cannot be baked directly in the carrier tape;
- Avoid excessive vibration or impact to prevent serious deformation or damage of packaging material.

8. Reliability Test

Table 12: Reliability Item

NO.	Testing Item	Test Condition	Result
1	High Temperature Storage	125°C, 1000h (JESD22-A103)	PASS
2	High Temperature & Humidity Test	85°C, 85%R.H., 1000h, V=Vcc max (JESD22-A101)	PASS
3	Thermal Shock Test	-40°C/0.5 hours ~125°C/0.5 hours, 500 cycles (JESD22-A106)	PASS
4	Mechanical Shock Test	3000g, 0.3ms, 6axes*3 times (JESD22-B110)	PASS
5	Vibration Test	From 20 to 2000Hz peak acceleration 20g, 16min/axis(4 cycles), X, Y and Z axis total 48 minutes (JESD22-B103)	PASS
6	HBM	±2KV, 3 times for each pad (JESD22-A114)	PASS

9. Package Specifications

9.1 Tape Specifications

Quantity per reel: 4500pcs.

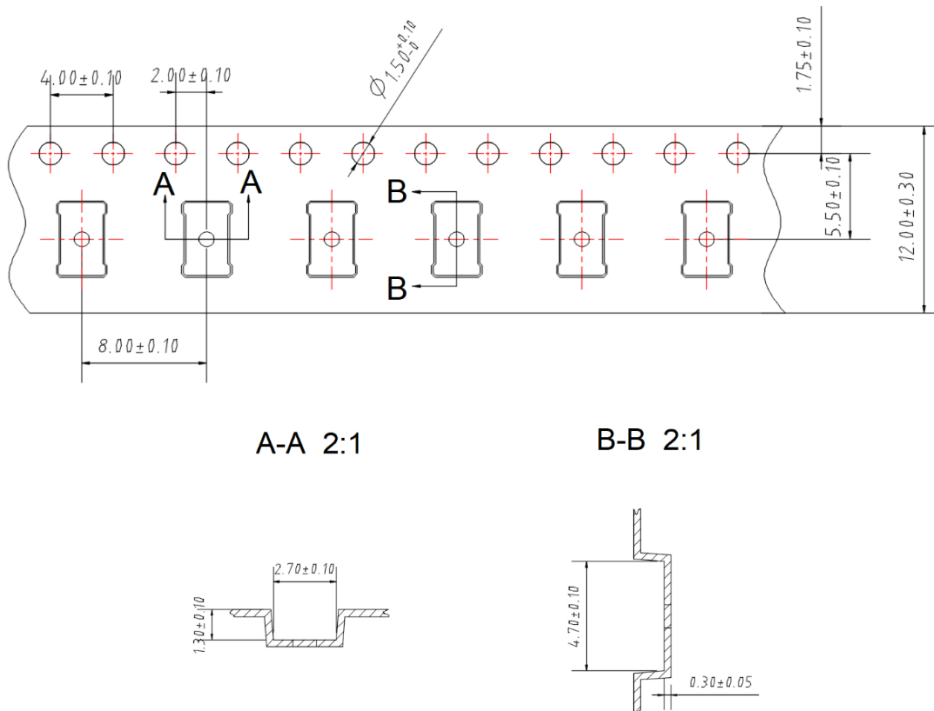

Figure 17: Tape Information (Unit: mm)

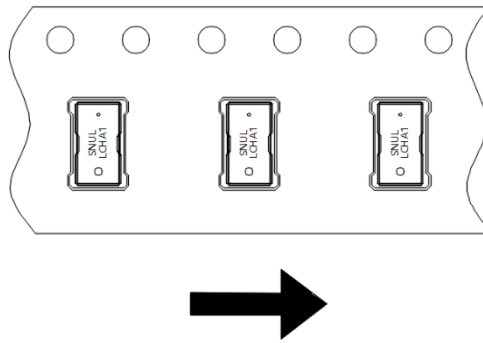
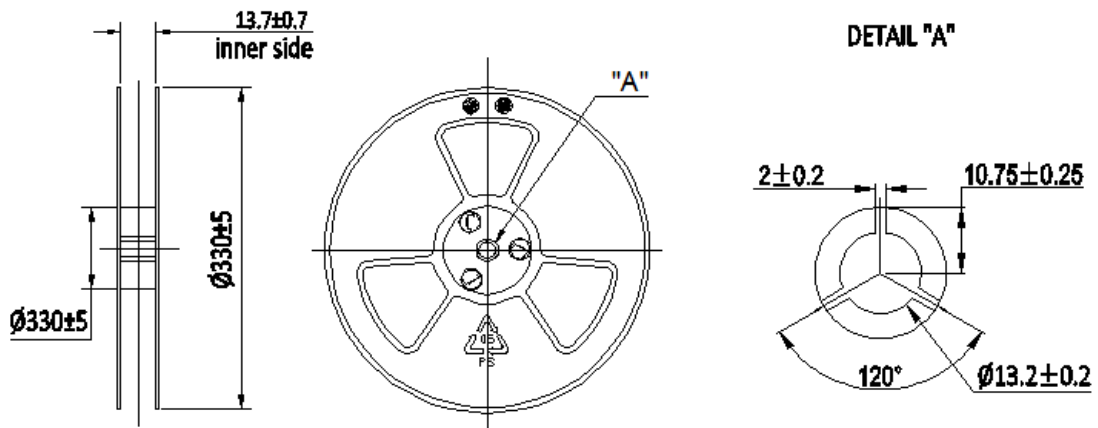

Figure 18: Pin Information

9.2 Reel Specification

13" reel will be provided for mass production stage and sample stage more than 1000pcs

13" Reel Specification (Unit: mm)



9.3 The content of Box

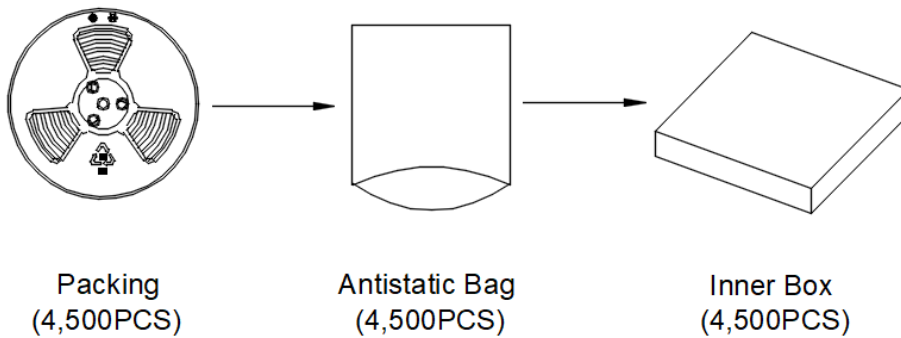

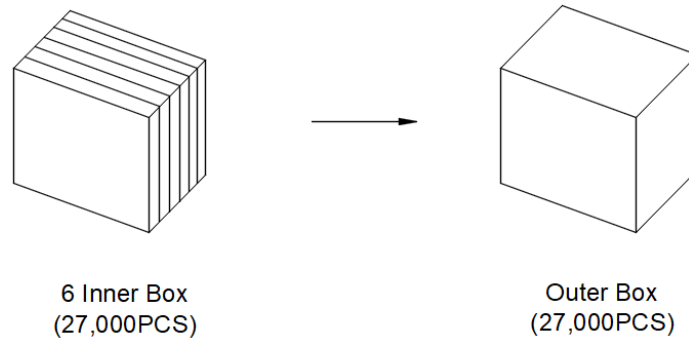

10. Laser eye safety

The SOT24-001 is designed to meet the Class 1 laser safety limits including single faults in compliance with IEC / EN 60825-1:2014. This applies to the stand-alone device and the included software supplied by Goermicro. In an end application system environment, the system may need to be tested to ensure it remains compliant. The system must not include any additional lens to concentrate the laser light or parameters set outside of the recommended operating conditions. Use outside of the recommended condition or any physical modification to the module during development could result in hazardous levels of radiation exposure.



11. Acronyms and abbreviations

Table 13: Acronyms and abbreviations

Abbr.	Definition
ESD	Electrostatic discharge
I ² C	Inter-integrated circuit (serial bus)
SPAD	Single photon avalanche diode
SPI	Serial Peripheral Interface
VCSEL	Vertical cavity surface emitting laser
ToF	Time of Flight
dToF	Direct Time of Flight
FoV	Field of view