

REVISIONS					
REV	ECO	DESCRIPTION	DATE	BY	APPR
A1	--	RELEASED DRAWING	Dec-26-2016	Ben	Tommy
A2	--	UPDATE NOTES	Jul-05-2017	Ben	Tommy
A3	--	UPDATE DRAWING	Mar-20-2018	White	Tommy

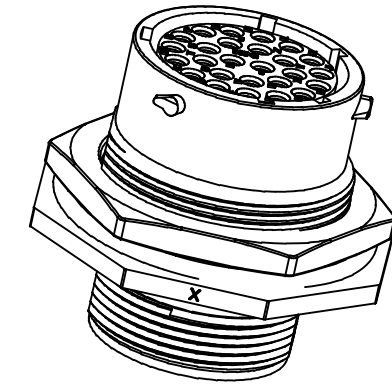

NOTES : (UNLESS OTHERWISE SPECIFIED)

1. MATERIAL :
  - SHELL : THERMOPLASTIC , UL94 V-0.
  - INSERT : THERMOPLASTIC , UL94 V-0.
  - O-RING : NBR/SILICONE RUBBER.
  - FIXED RUBBER: NBR OR SILICONE RUBBER.
  - SEAL GASKET : NBR/SILICONE RUBBER.
  - JAM NUT : ALUMINIUM ALLOY , BLACK ANODIZING.
2. SPECIFICATIONS :
  - 2.1 RATED CURRENT :
    - 2.1.1 STAMPED CONTACT 5A (MAX).
    - 2.1.2 MACHINED CONTACT 7.5A(MAX).
  - 2.2 RATED VOLTAGE : 250V(AC/DC).
  - 2.3 OPERATING TEMPERATURE : SEE TABLE.
  - 2.4 DIELECTRIC WITHSTANDING VOLTAGE : LESS THAN 2 MILLIAMPS CURRENT LEAKAGE@2000 VOLTS AC.
  - 2.5 INSULATION RESISTANCE : 5000 MEGOHMS MIN.
  - 2.6 IP--CLASS : IP67 AND IP69K IN THE MATED CONDITION, PANEL EXTERNAL.
  - 2.7 MATING CYCLES DURABILITY : 500 CYCLES MIN.
  - 2.8 RoHS COMPLIANT.
3. SUITABLE CONTACTS : 20# CONTACT.
4. ALL DIMENSIONS ARE FOR REFERENCE USE ONLY.

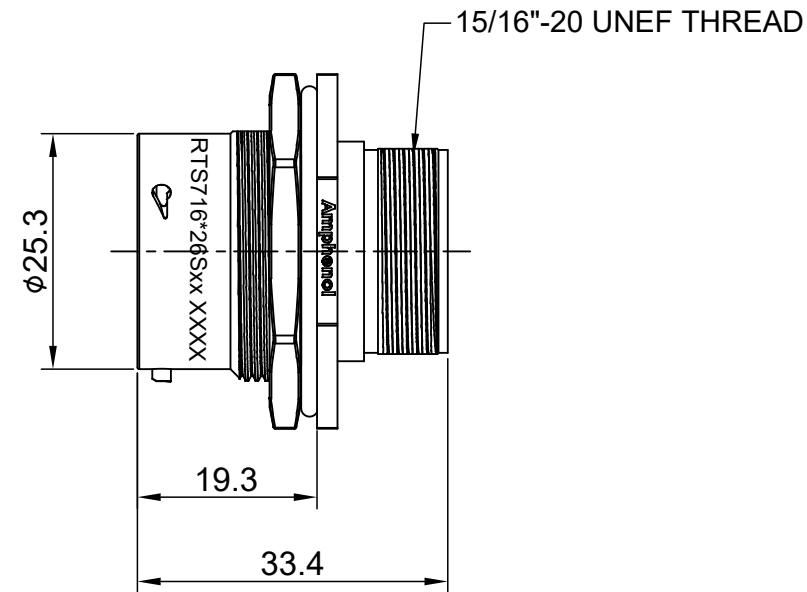
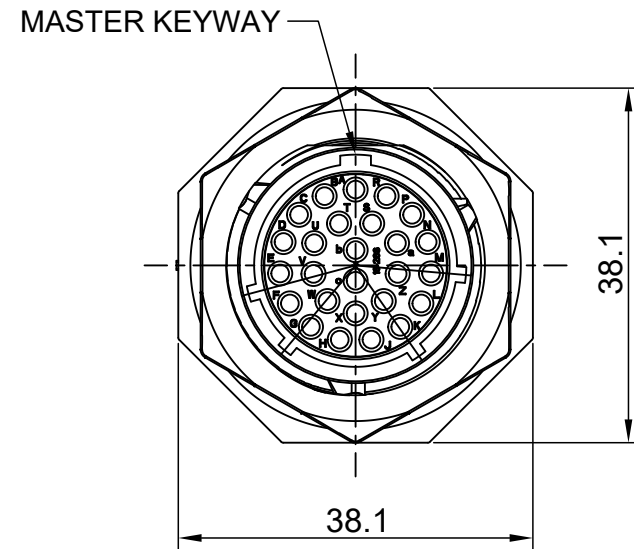
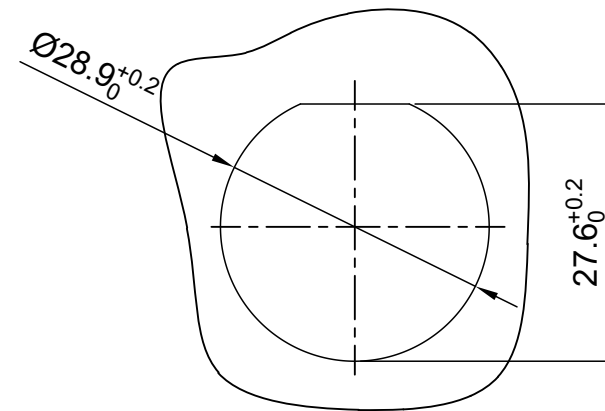

PANEL CUT OUT REFERENCE

KEY	PART NUMBER	
	-40°C ~ 105°C	-40°C ~ 125°C
N	RTS716N26S	RTS716N26S03

QUANTITY	PART NUMBER	DESCRIPTION	ITEM															
<b>MATERIALS LIST</b>																		
UNLESS OTHERWISE SPECIFIED 1) All dimensions are in metric(mm). 2) Tolerances are as follows: 1 PL DEC ±0.30    Fractions ±1/64 2 PL DEC ±0.15    Angles ±1° 3 PL DEC ±0.08 3) Note reference =		<table border="1"> <thead> <tr> <th colspan="2">SIGNATURES</th> <th>DATE</th> </tr> </thead> <tbody> <tr> <td>DRAWN: White</td> <td></td> <td>Mar-20-2018</td> </tr> <tr> <td>CHECKED: Tod</td> <td></td> <td>Mar-20-2018</td> </tr> <tr> <td>ENGINEER:</td> <td></td> <td></td> </tr> <tr> <td>APPROVAL: Tommy</td> <td></td> <td>Mar-20-2018</td> </tr> </tbody> </table>		SIGNATURES		DATE	DRAWN: White		Mar-20-2018	CHECKED: Tod		Mar-20-2018	ENGINEER:			APPROVAL: Tommy		Mar-20-2018
SIGNATURES		DATE																
DRAWN: White		Mar-20-2018																
CHECKED: Tod		Mar-20-2018																
ENGINEER:																		
APPROVAL: Tommy		Mar-20-2018																
MATERIAL SPECIFICATIONS:		<p style="text-align: center;"><b>Amphenol</b></p> <p style="text-align: center;">Sine Systems - www.amphenol-sine.com 44724 Morley Drive Clinton Township, MI 48036</p>																
PROCESS SPECIFICATIONS:		<p style="text-align: center;">ECO-MATE, RECEPTACLE, JAM NUT, SIZE 16, 26 POS, SOCKET.</p>																
NEXT ASSY:		<table border="1"> <tr> <td>SIZE</td> <td>TYPE</td> <td>DWG NO:</td> <td>REVISION</td> </tr> <tr> <td>B</td> <td>C-</td> <td>RTS716*26Sxx</td> <td>A3</td> </tr> <tr> <td colspan="2">SCALE: NONE</td> <td colspan="2">SHEET 1 OF 1</td> </tr> </table>		SIZE	TYPE	DWG NO:	REVISION	B	C-	RTS716*26Sxx	A3	SCALE: NONE		SHEET 1 OF 1				
SIZE	TYPE	DWG NO:	REVISION															
B	C-	RTS716*26Sxx	A3															
SCALE: NONE		SHEET 1 OF 1																

TITLE: ECO-MATE, RECEPTACLE, JAM NUT, SIZE 16, 26 POS, SOCKET.

DWG NO:

RTS716\*26Sxx

REV: A3

SH: 1

OF: 1

## ecomate® RM/RSSM/Aquarius™ - Contact Size 20 Options

Crimp Contacts, Machined				
Part Number		AWG	Wire Range (mm <sup>2</sup> )	Plating
Male	Female			
MP20W23F	MS20W23F	22-20	0.34-0.50	Gold Flash
MP20W23G5	MS20W23G5	22-20	0.34-0.50	Gold 5μ"
MP20W23G10	MS20W23G10	22-20	0.34-0.50	Gold 10μ"
MP20W23G15	MS20W23G15	22-20	0.34-0.50	Gold 15μ"
MP20W23G30	MS20W23G30	22-20	0.34-0.50	Gold 30μ"
MP24W23F	MS24W23F	26-24	0.13-0.25	Gold Flash
MP24W23G5	MS24W23G5	26-24	0.13-0.25	Gold 5μ"
MP24W23G10	MS24W23G10	26-24	0.13-0.25	Gold 10μ"
MP24W23G15	MS24W23G15	26-24	0.13-0.25	Gold 15μ"
MP24W23G30	MS24W23G30	26-24	0.13-0.25	Gold 30μ"
MP28W23F	MS28W23F	30-28	0.05-0.08	Gold Flash
MP28W23G5	MS28W23G5	30-28	0.05-0.08	Gold 5μ"
MP28W23G10	MS28W23G10	30-28	0.05-0.08	Gold 10μ"
MP28W23G15	MS28W23G15	30-28	0.05-0.08	Gold 15μ"
MP28W23G30	MS28W23G30	30-28	0.05-0.08	Gold 30μ"

Tooling, Machined	
Part Number	Description
QXRT20	Contact Extraction Tool, #20 (Ø 1.0) Contact
MFY-3959	Hand Crimp Tool for Machined Contacts
MFY-3960	Pneumatic Crimp Tool for Machined Contact

Plating Options, All	
Symbol	Plating
T	Tin Plated (for Stamped & Formed Contacts)
S	Silver Plated 5Um (for Machined Contacts)
F	Gold Plated
G5	Gold Plated (Thickness 5μ")
G10	Gold Plated (Thickness 10μ")
G15	Gold Plated (Thickness 15μ")
G30	Gold Plated (Thickness 30μ")

Crimp Contacts, Stamped & Formed				
Part Number		AWG	Wire Range (mm <sup>2</sup> )	Plating
Male	Female			
SP20W2F	SS20W2F	22-20	0.34-0.50	Gold Flash
SP20W2G5	SS20W2G5	22-20	0.34-0.50	Gold 5μ"
SP20W2G10	SS20W2G10	22-20	0.34-0.50	Gold 10μ"
SP20W2G15	SS20W2G15	22-20	0.34-0.50	Gold 15μ"
SP20W2G30	SS20W2G30	22-20	0.34-0.50	Gold 30μ"
SP24W2F	SS24W2F	26-24	0.14-0.25	Gold Flash
SP24W2G5	SS24W2G5	26-24	0.14-0.25	Gold 5μ"
SP24W2G10	SS24W2G10	26-24	0.14-0.25	Gold 10μ"
SP24W2G15	SS24W2G15	26-24	0.14-0.25	Gold 15μ"
SP24W2G30	SS24W2G30	26-24	0.14-0.25	Gold 30μ"
SP28W2F	SS28W2F	30-28	0.05-0.08	Gold Flash
SP28W2G5	SS28W2G5	30-28	0.05-0.08	Gold 5μ"
SP28W2G10	SS28W2G10	30-28	0.05-0.08	Gold 10μ"
SP28W2G15	SS28W2G15	30-28	0.05-0.08	Gold 15μ"
SP28W2G30	SS28W2G30	30-28	0.05-0.08	Gold 30μ"

Tooling, Stamped & Formed	
Part Number	Description
QXRT20	Contact Extraction Tool, #20 (Ø 1.0) Contact
MFY-3958	Hand Tool, Stamped & Formed Contact, Size 20, 20-28AWG
MFY-3957	Crimp Die for Stamped & Formed Contact

Misc Tooling, All	
Part Number	Description
CA-4020-59	Sealing Plug, Size 16 & 20

Standard Quantity Order Options	
Machined	Stamped & Formed
Bulk Package, 500 Pieces	Reel, 3000 Pieces