



RPPL12-36-35-PUMP

DATA SHEET

Outdoor Remote Power Systems

Features

- Capable of switching 40A with included relay to operate high startup current equipment like pumps and motors.
- Complete Remote Power Solution for Off-Grid operation
- Weatherproof, UV resistant, outdoor enclosures
- Enclosures can be Wall or Pole Mounted
- High Performance Valve Regulated Sealed Lead Acid Batteries
- Advanced battery charge controller protects against overcharge and over discharge



RemotePro®
RPPL12-36-35-PUMP

Applications

- Fuel Pumps
- Water Pumps
- Remote Lighting
- Motors
- Motorized Gates
- Backup Power Systems

Description

The RemotePro® RPPL12-36-35-PUMP outdoor remote Off-Grid power systems are specifically designed for applications that require a high current (up to 40A) intermittent power source such as pump and motorized equipment. The sealed and weatherproof glass filled Polycarbonate enclosures holds four batteries for a total of 12V 36Ah capacity. The enclosures are hinged and gasket sealed. They can accept a padlock or tamper seal.

The enclosures can be mounted to a wall or pole with the included mounting bracket system.

The high quality solar panels have a 25year power output guarantee. The 35W solar panels can be mounted to a 51mm to 101mm (2" to 4") diameter pole or alternately to a wall with the included bracket kit.

Features include an advanced battery charge controller to protect against over-charging or over-discharging of the valve regulated sealed lead acid batteries. Enclosures have multiple ports for cables. They are vented to prevent residual buildup of hydrogen gas.

Batteries are an Advance Glass Matt (AGM) type which have good all temperature deep discharge performance.



35W Solar Mount

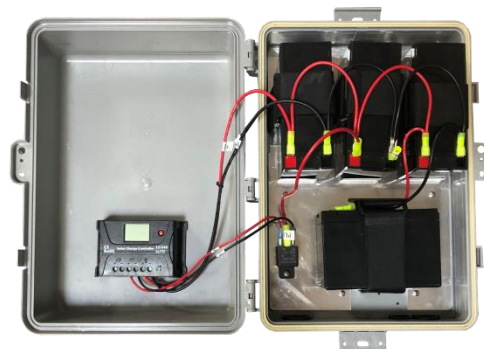

Inside Enclosure

Specifications

	RPPL12-36-35-PUMP
Rated Continuous Power Generation	8W
Reserve Time @ Rated Power	27hrs
Output Voltage (DC)	12V 40A via Relay
Battery Voltage (DC)	12V
Battery Capacity (Amp Hrs)	36Ah
Battery Type	Valve Regulated Sealed Lead Acid / Absorbent Glass Mat (AGM)
Battery Life	5 Years Typical
Controller Type	PWM 12/24V 20A
Overcharge Protection	14.4V
Over-discharge protection	11.0V
Over-discharge recovery volts	12.5V
Controller Self Consumption	< 0.5W
Enclosure Type	Glass Filled Polycarbonate
Enclosure External Size	17.5 x 12.5 x 6" (445 x 318 x 152mm)
Enclosure Internal Size	14 x 10 x 5" (356 x 254 x 127mm)
Solar Panel Dims	21.5" X 19.3" (545 x 490mm)
Operating Temperature	-30°C to +60°C (-22°F to 140°F)
System Weight (no batteries)	22lb (10kg)
Battery Weight	22lb (10kg)
Wind Speed Rating	110MPH (49m/s)
Warranty	3 Years

To determine maximum runtime available for intermittent high current applications:

- Solar Panel Watts x Peak Sun Hours = **Generated Whr** (Example; 35W x 6hr = 210Wh)
- Pump Amps x 12V = **Pump Watts** (Example; 15A x 12V = 180W)
- **Generated Wh / Pump Watts** (Example; 210Wh / 180W = 1.16hrs or 69 minutes total run time per day max)

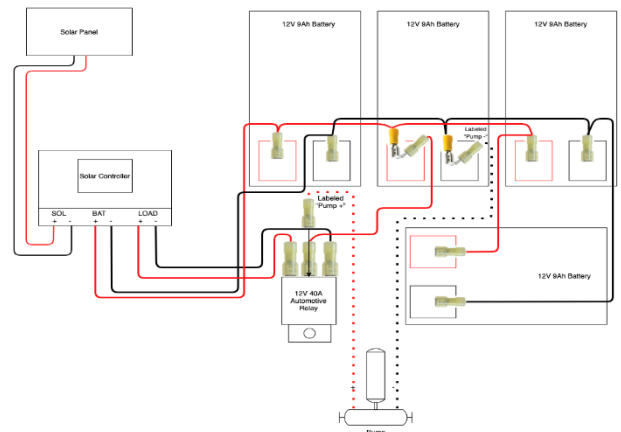

System Ordering:

RPPL12-36-35-PUMP 35W Solar, 12V 36AH (432Wh) Battery, 40A Intermittent Load, Off-Grid Power

For further information contact:

Tyconsystems.com

