

ROLLERS

Polyamide based (PA) technopolymer, black colour. Working temperature +90°/-20°C.

ROLLER HOLDER

Acetal resin based (POM) technopolymer, black colour.

FEATURES AND APPLICATIONS

- The roller elements, suitably fixed inside the RLT-AL aluminum profiles (Fig. 1) create modular roller tracks for idle handling (both as sliding or containing surfaces), suitable for several applications in different fields: feeding and discharging benches in construction machinery, storage and picking systems, packaging machinery, etc..
- RLT-U15 roller elements are suitable for handling of packages with reduced weight and size. The smaller diameter of the rollers ensures a reduction in vibrations and consequently a lower noise during handling of packages.
- The low friction coefficient between the roller and the roller holder eliminates the need for lubrication maintenance.
- The particular section of RLT-AL profile allows the snap-in assembly of the roller elements into the profile without the need for screws or other fasteners (Fig.1). Therefore the roller elements may be quickly and easily removed and replaced, without disassembling the entire roller track.
- The roller elements are divisible in correspondence of predefined sections (Fig.2) so as to create roller tracks of the precise required length.
- All the accessories of ELEROLL series can also be used with the RLT-U15 roller elements, except for RLT-B brakes.

TECHNICAL DATA

See: ELEROLL Modular roller tracks (on page 1101).

SPECIAL EXECUTIONS ON REQUEST

Thermoplastic (TPU) polyurethane rollers.



F&M design

ele:roll

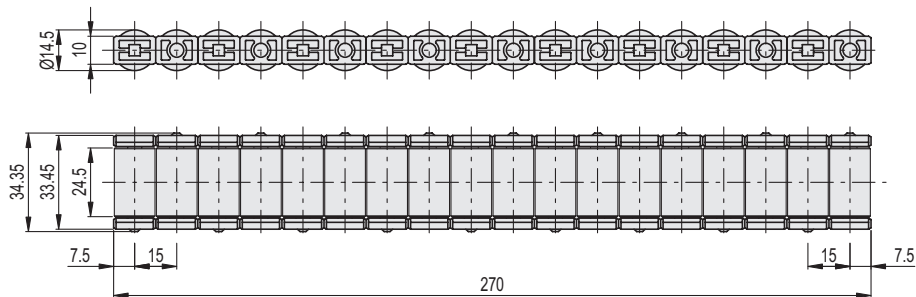
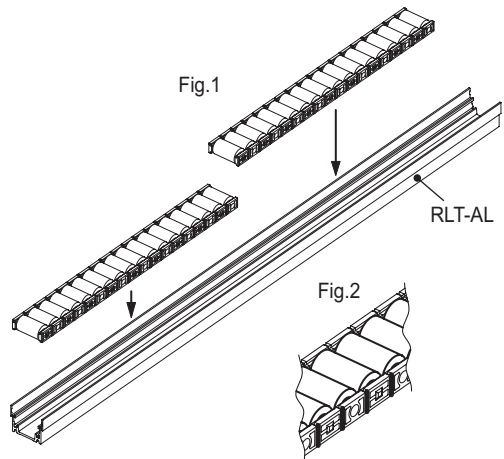

METRIC

Code	Description	⚖
429807	RLT-U15-PA	102

